

Effect

LED-illuminated rectangular mirror with frosted strip, illuminated magnifying mirror (3X) and touch-switch for color temperature control

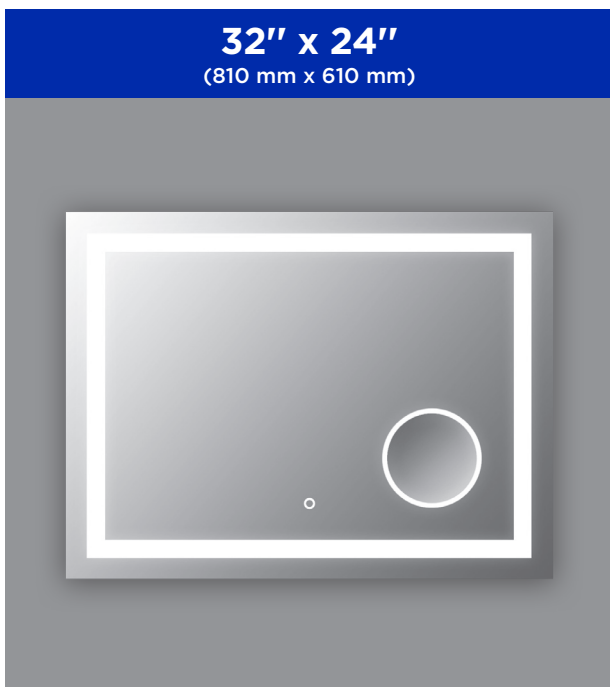

FEATURES

Code	MR1785-570-001
Packaging mm (in)	930 x 720 x 90 (36.6 x 28.3 x 3.5)
Mirror thickness	4 mm
Weight kg (lb)	10.1 (22.3)
Certification	cUL_{us}
Anti-fog system	Included
Magnifying mirror (3X)	Included
Reversible	Yes
Total thickness	45 mm (1 3/4")
Automatically opens with wall switch	Yes

LIGHTING

Power (watt)	46 W
Input (volt)	120 V
Lumens	1815 lm
Color temperature controlled by maintaining the touch-switch	from 2700k to 6000k
Frequency	60 Hz
Color Rendering Index (CRI)	90+

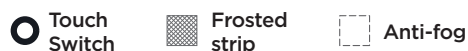
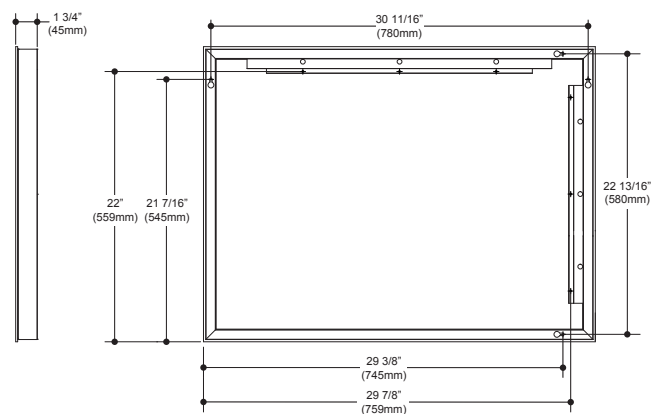
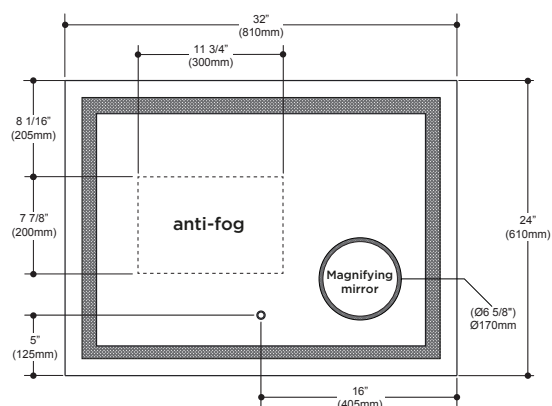

MR1785

Miraz