

SPECIFICATION SUBMITTAL SHEET

j o n e s s t e p h e n s c o r p o r a t i o n

ECONOMY SHOVEL

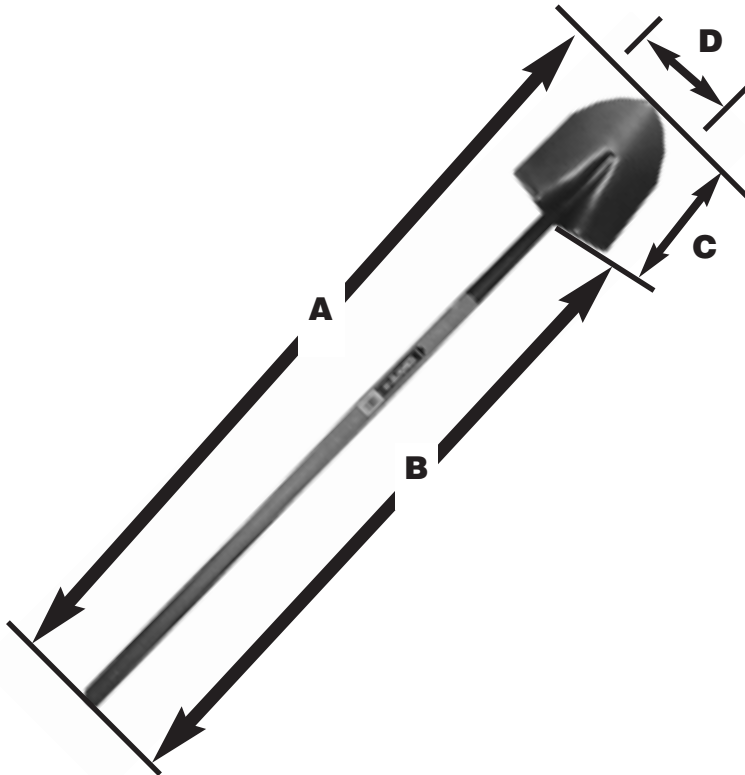

PART NO. S49-431

features and benefits:

This product and others like it can be found in the Jones Stephens catalog. Call today to order your catalog or download it from our website: www.plumbest.com

PART NO.	DESCRIPTION	A	B	C	D
<input type="checkbox"/> S49-431	Long handle round point	4'8"	46 1/2"	10 7/8"	8"

jones stephens corporation
3249 moody parkway • moody, alabama 35004
toll free phone: 1-800-355-6637 • toll free fax: 1-800-462-6991
www.plumbest.com