

SPECIFICATION SUBMITTAL SHEET

JONES STEPHENS CORPORATION

FIP x OD ANGLE SUPPLY STOP 1/4 TURN

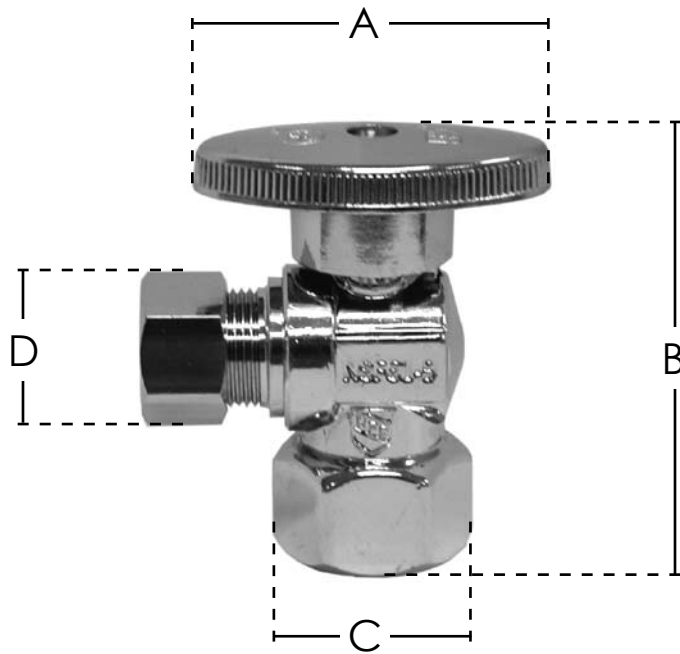

features and benefits:

- ◆ UPC listed
- ◆ LEAD FREE

This product and others like it can be found in the Jones Stephens catalog. Call today to order your catalog or download it from our website:
www.plumbest.com

PART NO.	DESCRIPTION	A	B	C	D
□ S10-310	1/2" FIP x 3/8" OD Angle	1 3/4"	2 1/4"	1"	5/8"

Jones Stephens Corporation
3249 Moody Parkway • Moody, Alabama 35004
Toll Free Phone: 1-800-355-6637 • Toll Free Fax: 1-800-462-6991
www.plumbest.com