

SPECIFICATION SUBMITTAL SHEET

jones stephens corporation

HEAVY ADJUSTABLE SHOWER ARM

PART NO. S01-039

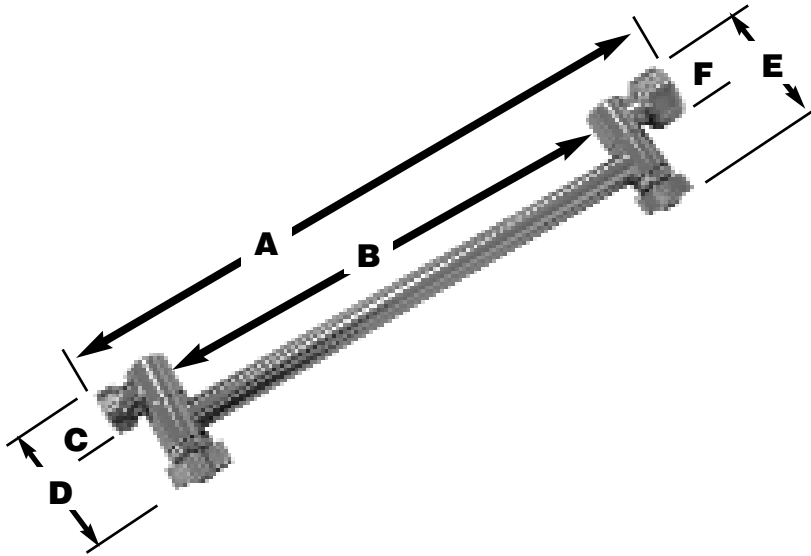

features and benefits:

- Chrome plated brass
- 10" length
- Locking wing nut adjustment

This product and others like it can be found in the Jones Stephens catalog. Call today to order your catalog or download it from our website: www.plumbest.com

PART NO.	DESCRIPTION	A	B	C	D	E	F
S01-039	1/2" x 10" adjustable	11-3/16"	8-3/8"	3/4"	2-1/4"	2-1/4"	15/16"

jones stephens corporation
3249 moody parkway • moody, alabama 35004
toll free phone: 1-800-355-6637 • toll free fax: 1-800-462-6991
www.plumbest.com