

# SPECIFICATION SUBMITTAL SHEET

jones stephens corporation

## ADJUSTABLE LAVATORY HANGER

### PART NO. L56-027

#### features and benefits:

- Durable cast iron
- Adjusts from 10 1/2" to 15 1/2"
- For iron, lugs fit into pockets
- For china, remove side lugs

This product and others like it can be found in the Jones Stephens catalog. Call today to order your catalog or download it from our website: [www.plumbest.com](http://www.plumbest.com)

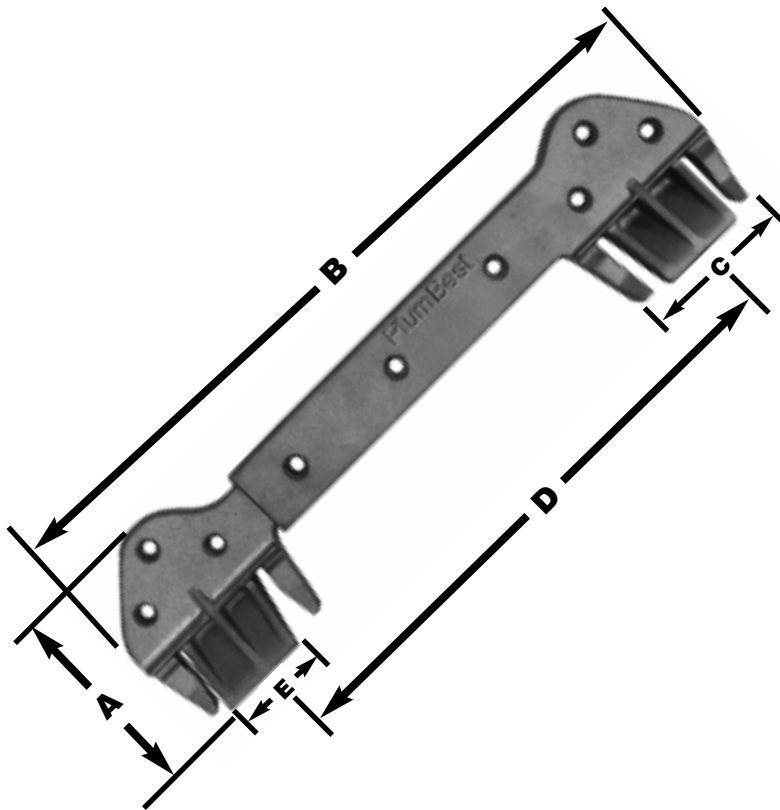

PART NO.	DESCRIPTION	A	B	C	D	E
□ L56-027	Lavatory Hanger	3 3/8"	13 1/2"	3"	10 1/2"-15 1/2"	1 5/8"

jones stephens corporation  
 3249 moody parkway • moody, alabama 35004  
 toll free phone: 1-800-355-6637 • toll free fax: 1-800-462-6991  
[www.plumbest.com](http://www.plumbest.com)