

# SPECIFICATION SUBMITTAL SHEET

jones stephens corporation

## DRINKING FOUNTAIN BUBBLER WITH FACE GUARD

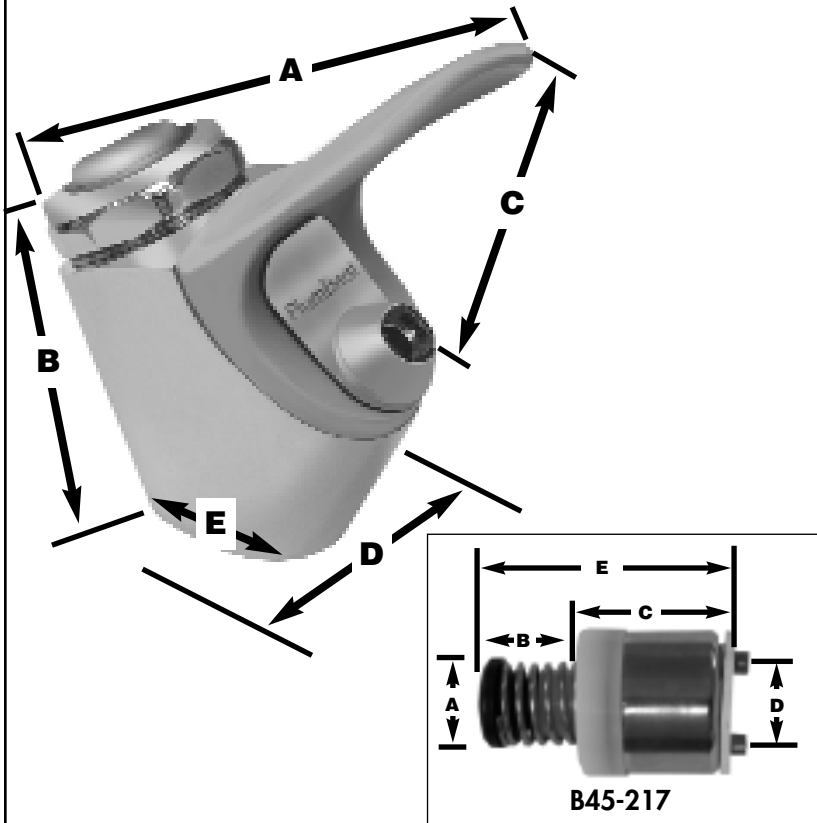

### features and benefits:

- LEAD FREE - Meets NSF 61.9
- Chrome Plated Brass Body
- Equipped with unique neo-poly water shield to prevent injuries to teeth, gums and face
- Mildew resistant
- 3/8" FIP connection
- Stainless steel cartridge
- Tamper proof design requires 5/16" hex key to remove/replace water shield for cleaning
- Perfect for schools
- B45-218 Kit includes new water shield, washer, and retainer nut

This product and others like it can be found in the Jones Stephens catalog. Call today to order your catalog or download it from our website: [www.plumbest.com](http://www.plumbest.com)

PART NO.	DESCRIPTION	A	B	C	D	E
<input type="checkbox"/> B45-216	Replacement Cartridge	3 3/16"	2 1/4"	2"	2 1/4"	1 9/16"
<input type="checkbox"/> B45-217	Bubbler	11/16"	11/16"	1"	19/32"	1 3/4"

jones stephens corporation  
 3249 moody parkway • moody, alabama 35004  
 toll free phone: 1-800-355-6637 • toll free fax: 1-800-462-6991  
[www.plumbest.com](http://www.plumbest.com)