

SPECIFICATION SUBMITTAL SHEET

jones stephens corporation

LONG REACH BAR TAP FAUCET

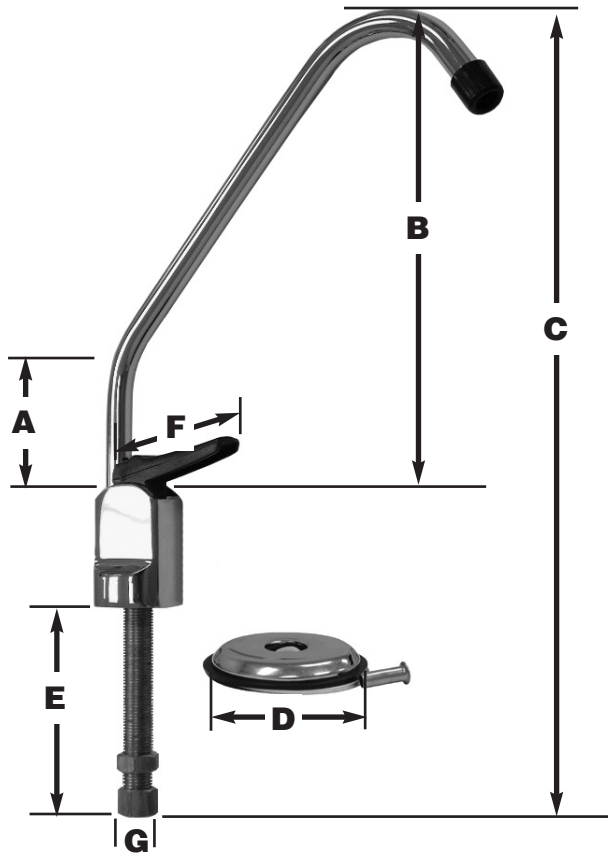

PART NO. B45-014

features and benefits:

- 1/4" connection
- 10" meets NSF 61.9

This product and others like it can be found in the Jones Stephens catalog. Call today to order your catalog or download it from our website: www.plumbest.com

PART NO.	A	B	C	D	E	F	G
□ B45-014	2"	6"	10"	2-7/8"	2"	1-3/4"	3/8" OD

jones stephens corporation
 3249 moody parkway • moody, alabama 35004
 toll free phone: 1-800-355-6637 • toll free fax: 1-800-462-6991
www.plumbest.com