

# SPECIFICATION SUBMITTAL SHEET

JONES STEPHENS CORPORATION

## BASKET STRAINER

### features & benefits:

- Simple to install, operate & maintain
- Positive Seal
- Stainless steel flange and basket
- Positive seal
- PVD on Polished Nickel
- Clamshell or box packaging

This product and others like it can be found in the Jones Stephens catalog. Call today to order your catalog or download it from our website:  
[www.plumbest.com](http://www.plumbest.com)

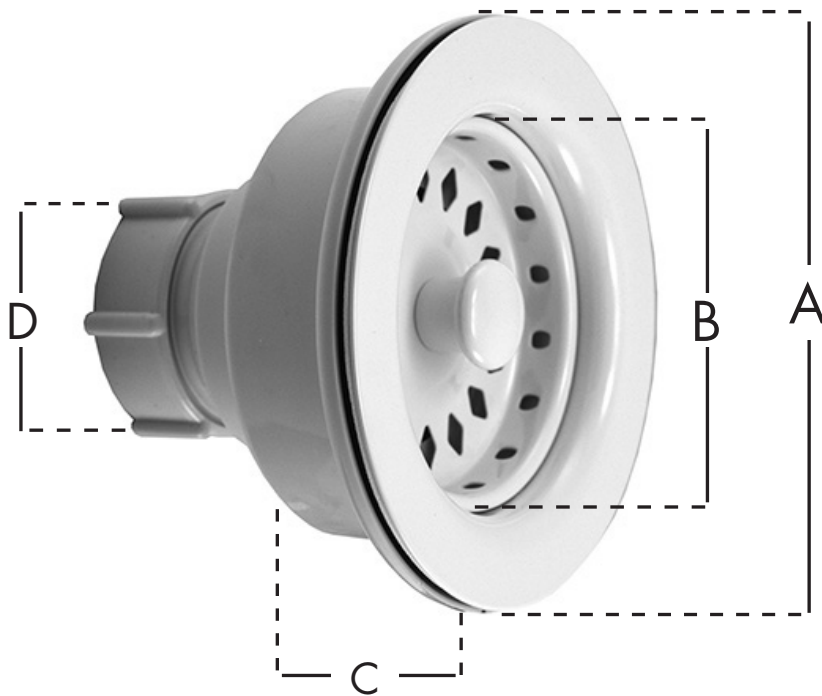

PART NO.	DESCRIPTION	A	B	C	D
□ B02001	Polar White	4-1/2"	3"	1-3/8"	2-1/4"

Jones Stephens Corporation  
3249 Moody Parkway • Moody, Alabama 35004  
Toll Free Phone: 1-800-355-6637 • Toll Free Fax: 1-800-462-6991  
[www.plumbest.com](http://www.plumbest.com)