

# Thermoplastic Valve



PVC • Schedule 40 • Threaded Connection • 150 WOG



T-702

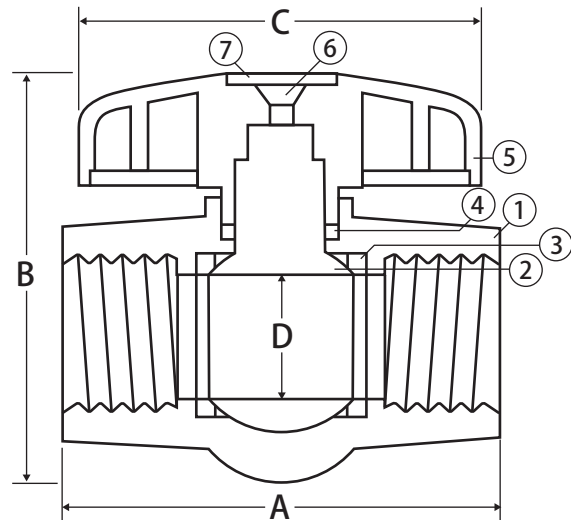

## Features

- **NPS connections**
- Each valve tested in open and closed position
- Minimal pressure drop/turbulence
- Large ports for greater flow
- Corrosion resistant PVC material
- Wetted surfaces contain less than .25% lead content

## Approvals

- NSF 61-8 Certified
- NSF 61 - Annex G
- NSF 372
- NSF/ANSI 14
- ANSI B1.20.1
- ASTM F1970

## Pressure Rating

- Max service temperature 140°F, 150 PSI @ 73°F continuous
- Min temperature 41°F

## Material Specifications

No.	Part	Materials
1	Body	UPVC
2	Ball / Stem	UPVC
3	Seat (2)	EPDM
4	O-ring	EPDM
5	Handle	ABS Plastic
6	Bolt	Steel - Zinc Plated
7	Cap	ABS Plastic

## Dimensions

Part No.	Size	A	B	C	D
210-703	1/2"	3.27	2.52	2.76	0.55
210-704	3/4"	3.74	3.11	3.46	0.79
210-705	1"	4.17	3.74	3.94	0.98
210-706	1-1/4"	4.49	3.90	3.94	1.18
210-707	1-1/2"	5.12	4.53	4.29	1.42
210-708	2"	5.79	5.31	5.28	1.83



**WARNING:** This product can expose you to chemicals including lead, which is known to the State of California to cause cancer, and lead, which is known to the State of California to cause birth defects or other reproductive harm. For more information go to [www.P65Warnings.ca.gov](http://www.P65Warnings.ca.gov).