

Brass Horizontal Swing Check Valve

Solder Connection • 200 WOG • Class 125

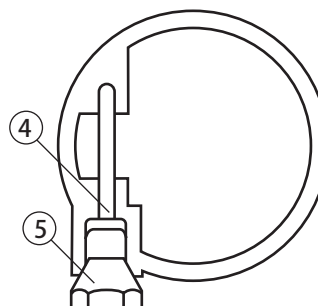

S-501

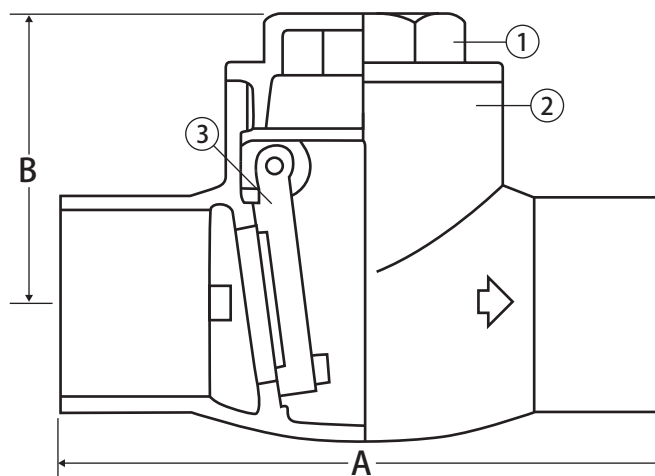

Features

- Residential and commercial applications

Approvals

- ASME/ANSI B16.18

Pressure Rating

- 200 WOG

Recommended Install: 5 pipe diameter minimum downstream from pump discharge or changes in direction to avoid flow turbulence. Flow straighteners may be required in extreme cases.

Note: On pump discharge, the preferred check valves are: inline, spring assisted, center-guided, and inline checks.

Material Specifications

No.	Part	Materials
1	Cap	Cast Brass
2	Body	Cast Brass
3	Disc	Forged Brass
4	Hinge Pin	Brass
5	Screw	Brass

Dimensions

Part No.	Size	A	B
105-203	1/2"	2.52	1.54
105-204	3/4 "	1.54	1.62
105-205	1"	3.90	1.77
105-206	1-1/4"	4.37	2.01
105-207	1-1/2"	4.96	2.25
105-208	2"	5.99	2.68



WARNING: This product can expose you to chemicals including lead, which is known to the State of California to cause cancer, and lead, which is known to the State of California to cause birth defects or other reproductive harm. For more information go to www.P65Warnings.ca.gov.