

Dielectric Union

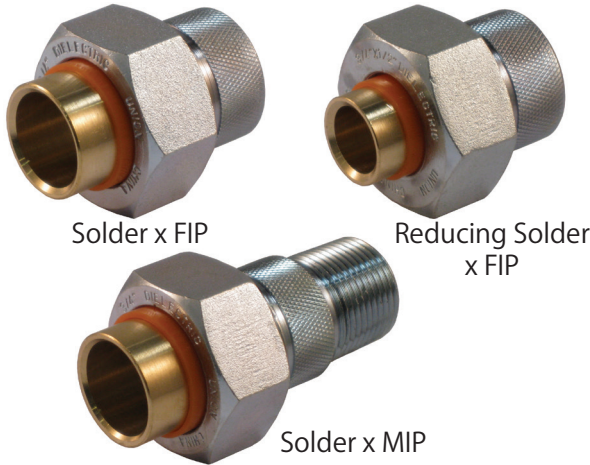

Brass Solder x Galvanized • 250 PSI



Brass Solder x Galvanized

Features

- Prevents accelerated corrosion
- -20°F to 180°F - Buna Seats

Approvals

- Meets ANSI B16.39
- ANSI B1.20.1
- Solder end ANSI B16.18

Pressure Rating

- 250 PSI

Dimensions

Part No.	Size	A	B	C
Solder x FIP				
701-103	1/2" SWT x 1/2" FIP	1.87	1.61	0.65
701-104	3/4" SWT x 3/4" FIP	2.11	1.83	0.79
701-105	1" SWT x 1" FIP	2.34	2.15	0.86
701-106	1-1/4" SWT x 1-1/4" FIP	2.50	2.59	0.94
701-107	1-1/2" SWT x 1-1/2" FIP	2.79	2.95	1.11
701-108	2" SWT x 2" FIP	3.09	3.75	1.32
Reducing Solder x FIP				
701-204	1/2" SWT x 3/4" FIP	1.95	1.83	0.65
701-205	3/4" SWT x 1" FIP	2.10	2.15	0.68
Solder x MIP				
701-303	1/2" SWT x 1/2" MIP	2.85	1.61	0.65
701-304	3/4" SWT x 3/4" MIP	3.01	1.83	0.79
701-305	3/4" SWT x 1/2" MIP	2.62	1.83	0.65
701-306	1" SWT x 1" MIP	3.18	2.15	0.86

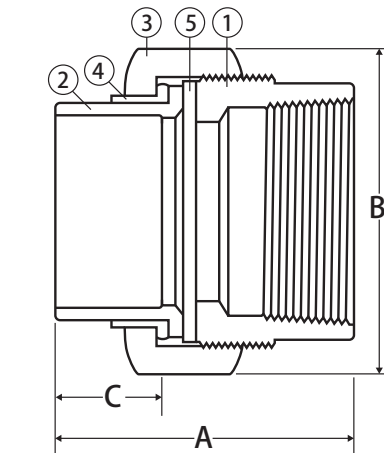

Solder x FIP

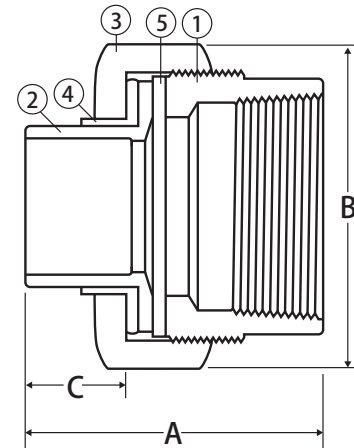

Reducing Solder x FIP

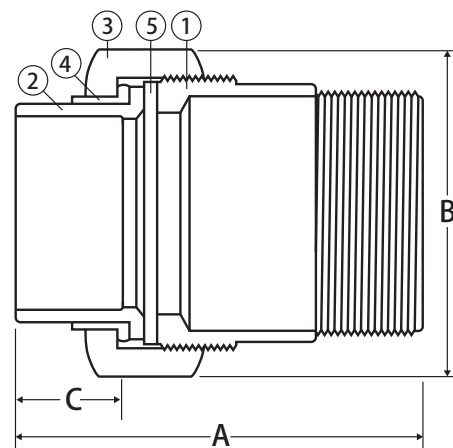

Solder x MIP

Material Specifications

No.	Part	Materials
1	Body	Steel - Zinc Plated
2	Tail Piece	Brass
3	Union Nut	Steel - Zinc Plated
4	Dielectric Ring	Nylon 66
5	Gasket*	Buna-N



WARNING: This product can expose you to chemicals including lead, which is known to the State of California to cause cancer, and lead, which is known to the State of California to cause birth defects or other reproductive harm. For more information go to www.P65Warnings.ca.gov.