

# Lockwing



## Utility Gas Ball Valve • Full Port • Male x Male Connection • Service Bypass • 175 PSIG



175-LWMBP

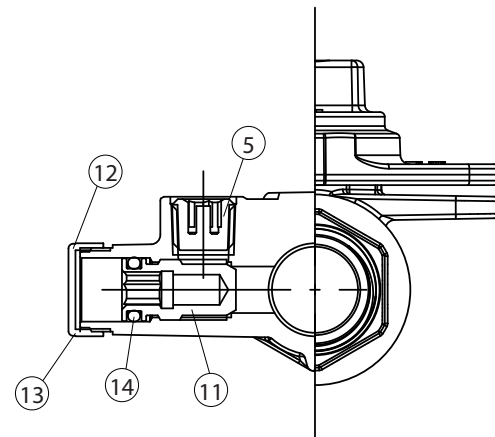
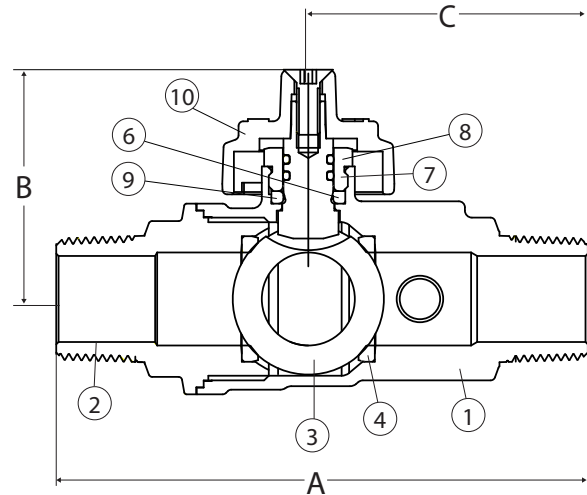

### Features

- Tamper resistant lockwing cap
- 2 Viton® o-rings
- Full port design to accommodate industry leading stop changers
- Lockwing accommodates standard barrel locks
- Maintenance free design
- 100% leak tested
- 100% Made in Italy
- Leakproof stem - Lifetime Warranty
- Patented security shutter and lockwing tab
  - US Patent no. 6,648,009

### Approvals

- CSA Certified
  - CGA 3.16 (175SG)
  - ANSI B16.33 (175G)
- Meets or exceeds applicable part of DOT 192 and ANSI B16.33
- MSS SP-110

### Pressure Rating

- 175 PSIG
- Temp range: -20°F to 300°F

### Material Specifications

No.	Part	Materials
1	Body	Chrome Plated Brass - CW617N
2	End Connection	Chrome Plated Brass - CW617N
3	Ball	Chrome Plated Brass - CW617N
4	Seat (2)	PTFE
5	Set Screw	Brass - CW614N
6	Stem	Brass - CW614N
7	Stem O-ring (2)	FKM
8	Packing Gland	Brass - CW614N
9	Packing	NBR
10	Lockable Cap	Brass - CW617N
11	Shutter	Brass - CW614N
12	Washer	Vulkan Fiber
13	Cap	Brass - CW614N
14	Screw	304 Stainless Steel
14	Bypass Cap	Brass - CW614N

### Dimensions

Part No.	Size	A	B	C	D
244-004B	3/4"	4.50	1.94	1.55	0.75