

60"

Item Number:

JAMES MARTIN

Sonoma 60" Double Vanity

860-V60D-CFO  
860-V60D-SOK



VANITIES

Diagrams with Dimensions  
page 01 of 03

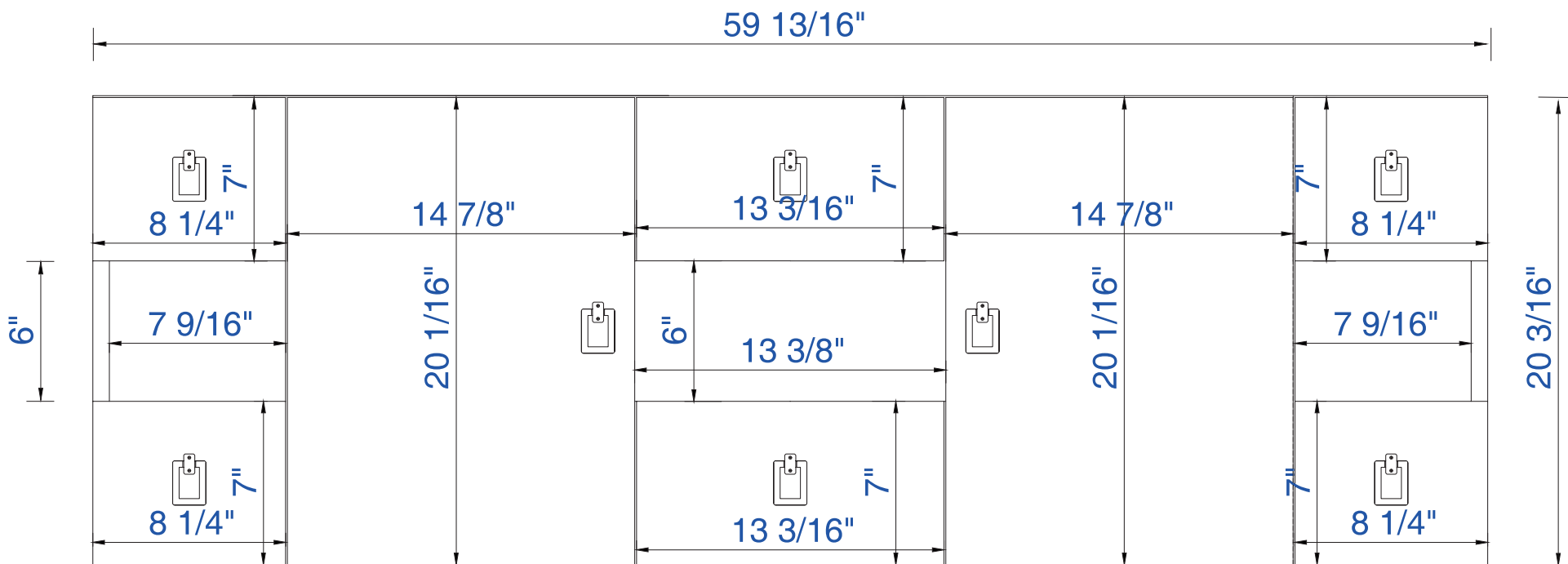

NOTE ONE: Countertops are not shown in these diagrams. (Cabinet Only)

NOTE TWO: This vanity does not have a Backsplash.

Please consult our website for Countertop Diagrams: [www.jamesmartinvanities.com](http://www.jamesmartinvanities.com)

60"

Item Number:

860-V60D-CFO  
860-V60D-SOK

JAMES MARTIN



VANITIES

Sonoma 60" Double Vanity

Diagrams with Dimensions  
page 02 of 03



NOTE ONE: Countertops are not shown in these diagrams. (Cabinet Only)

NOTE TWO: Internal Shelves (Shown) are designed to align with sinks in James Martin's Optional Countertops. Customers' own countertops and sinks may align differently, and modification may be required. Please consult our website for Countertop Diagrams: [www.jamesmartinvanities.com](http://www.jamesmartinvanities.com)

60"

Item Number:

860-V60D-CFO  
860-V60D-SOK

JAMES MARTIN



VANITIES

Sonoma 60" Double Vanity

Diagrams with Dimensions  
page 03 of 03

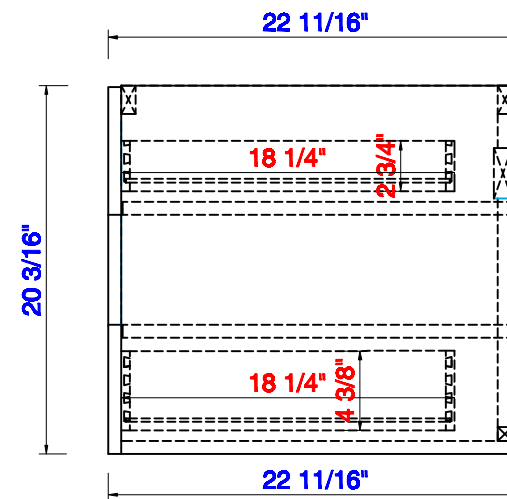
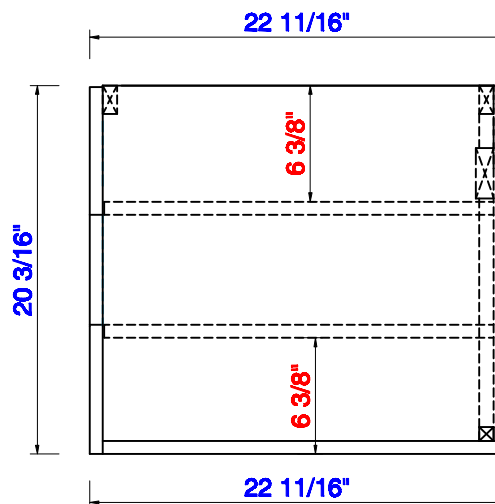
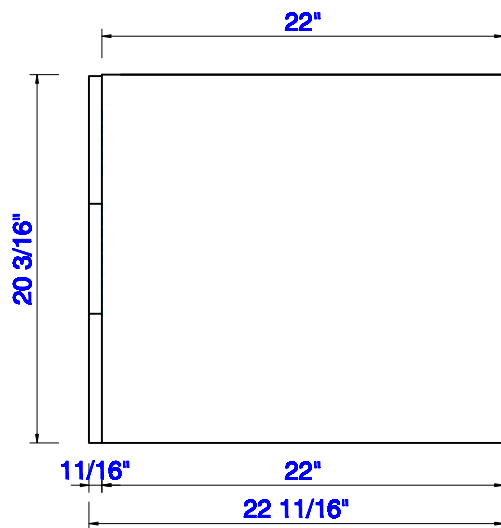

NOTE ONE: Countertops are not shown in these diagrams. (Cabinet Only)

NOTE TWO: This vanity does not have a Backsplash.

Please consult our website for Countertop Diagrams: [www.jamesmartinvanities.com](http://www.jamesmartinvanities.com)

1524mm

Item Number:

860-V60D-CFO  
860-V60D-SOK

JAMES MARTIN



VANITIES

Sonoma 1524mm Double Vanity

Diagrams with Dimensions  
page 01 of 03

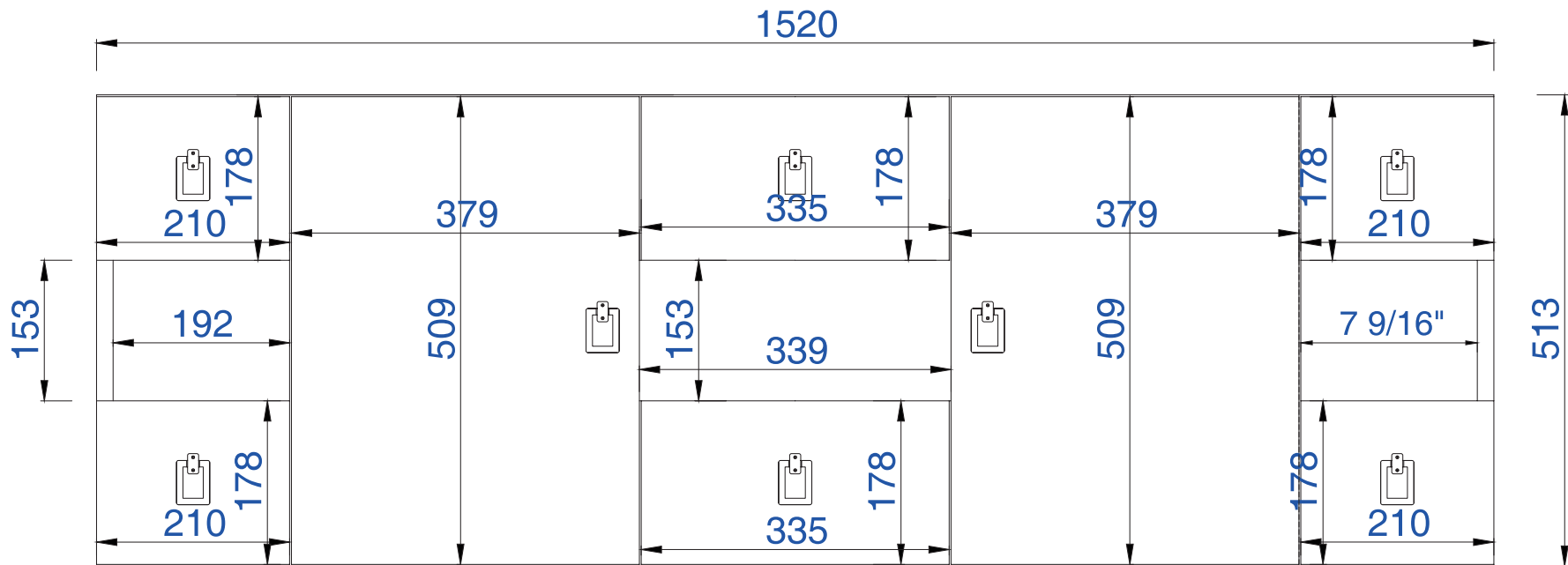

NOTE ONE: Countertops are not shown in these diagrams. (Cabinet Only)

NOTE TWO: This vanity does not have a Backsplash.

Please consult our website for Countertop Diagrams: [www.jamesmartinvanities.com](http://www.jamesmartinvanities.com)

1524mm

Item Number:

860-V60D-CFO  
860-V60D-SOK

JAMES MARTIN



VANITIES

Sonoma 1524mm Double Vanity

Diagrams with Dimensions  
page 02 of 03

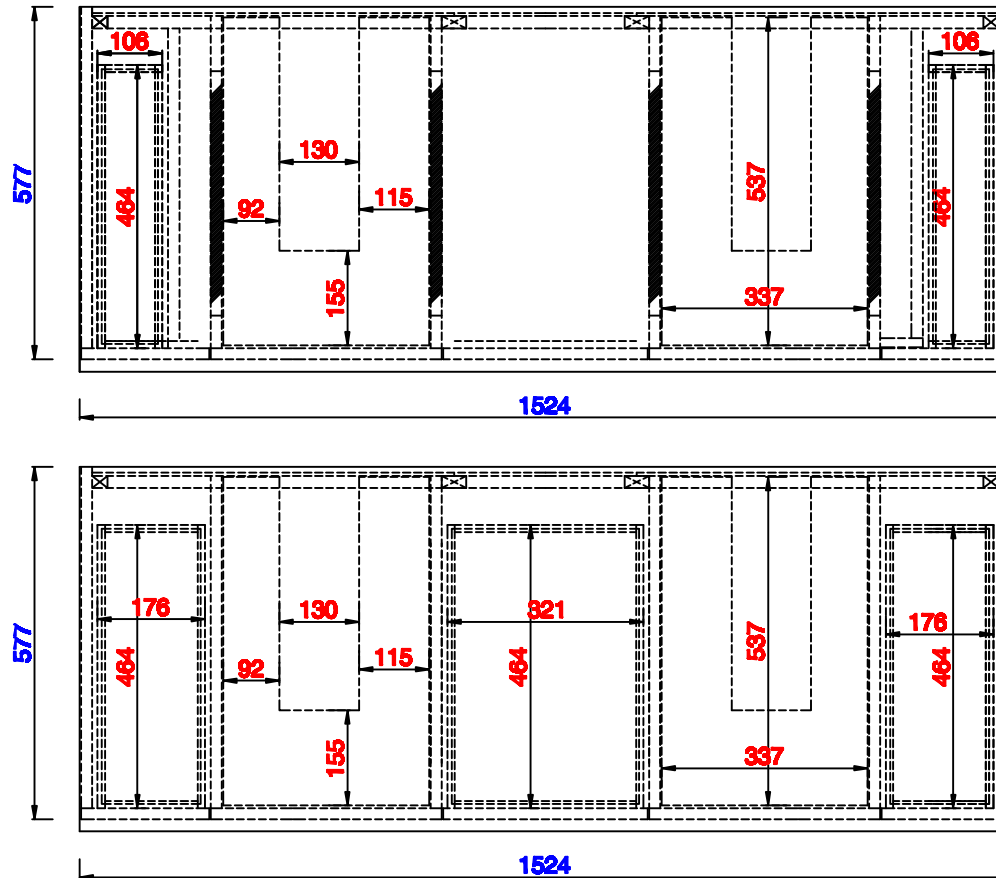

NOTE ONE: Countertops are not shown in these diagrams. (Cabinet Only)

NOTE TWO: Internal Shelves (Shown) are designed to align with sinks in James Martin's Optional Countertops. Customers' own countertops and sinks may align differently, and modification may be required. Please consult our website for Countertop Diagrams: [www.jamesmartinvanities.com](http://www.jamesmartinvanities.com)

1524mm

Item Number:

860-V60D-CFO  
860-V60D-SOK

JAMES MARTIN



VANITIES

### Sonoma 1524mm Double Vanity

Diagrams with Dimensions  
page 03 of 03

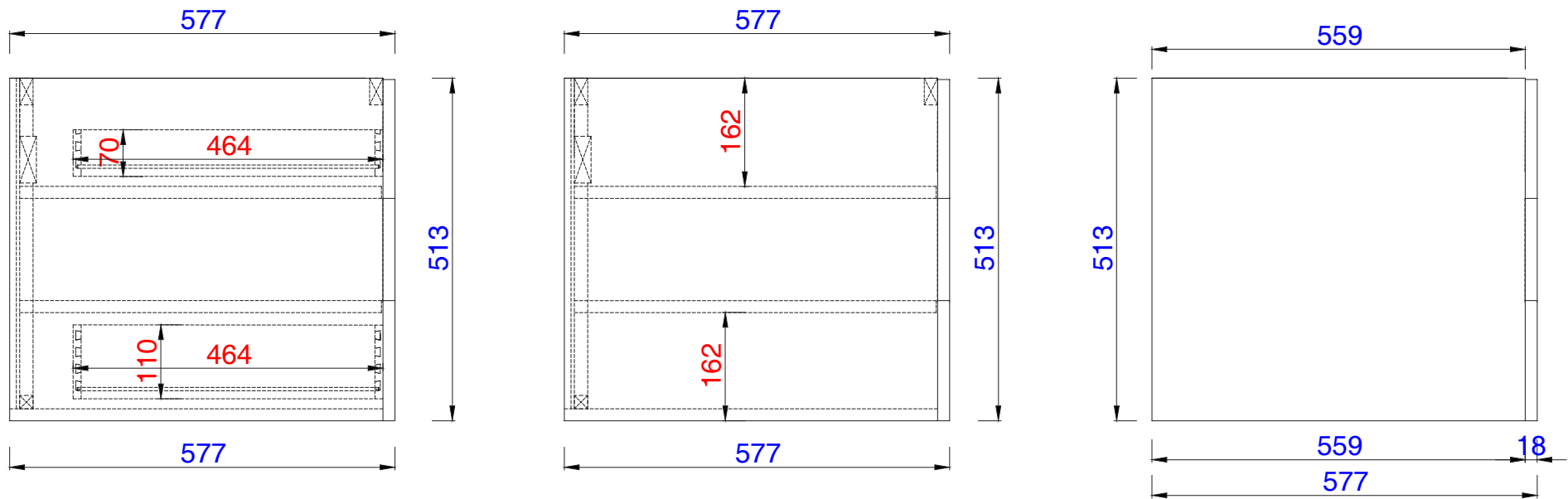

NOTE ONE: Countertops are not shown in these diagrams. (Cabinet Only)

NOTE TWO: This vanity does not have a Backsplash.

Please consult our website for Countertop Diagrams: [www.jamesmartinvanities.com](http://www.jamesmartinvanities.com)