

Pure Basin Mixer Low

by JEE-O



 brushed
300-1700

 polished
300-1701

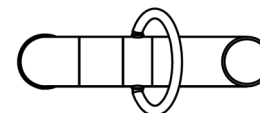
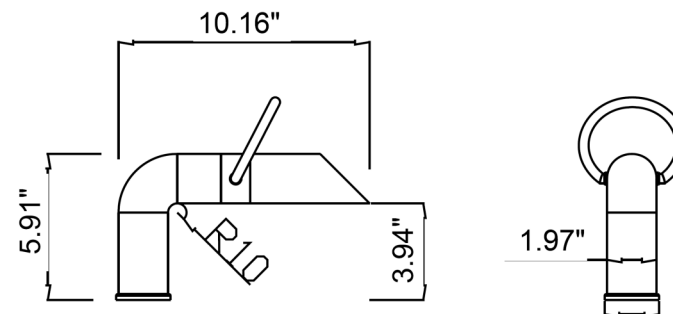

SPECIFICATIONS

MATERIAL:	304 stainless steel
FEATURES:	pressure balance valve
CARTRIDGE:	progressive mixing mechanism (#005-0201)
FLOW RATE:	2.4 GPM / 1.2 GPM in California (adjustable on request)
WEIGHT:	7 lbs
PACKAGE DIMENSIONS:	L 18" x W 11" x H 6"
DELIVERY WEIGHT:	8 lbs
WARRANTY:	2-year limited warranty

MAINTENANCE & CARE

BRUSHED:	Regularly apply stainless steel cleaner and rub in the direction of the grain, using a slightly abrasive sponge.
POLISHED:	Regularly apply stainless steel cleaner and use a soft cloth.

middle off



right water flow

