

ID Infinity Drain

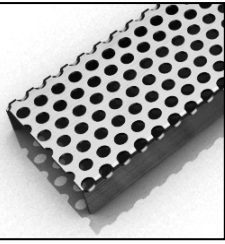

S-DGAS 99 Series

SITE SIZABLE STAINLESS STEEL

- S-DGAS 9936 - 36" Complete Kit
- S-DGAS 9948 - 48" Complete Kit
- S-DGAS 9960 - 60" Complete Kit
- S-DGAS 9972 - 72" Complete Kit
- S-DGAS 9996 - 96" Complete Kit

Features

- Modify length and outlet location on site
- Indoor or outdoor use
- Stainless steel channel
- 16 gauge, 304L stainless steel perforated grate
- Works with 3" clamp down floor with 4" throat/strainer size *(included)*
- Compatible with: PVC Liner, Rubber Liner (Chloraloy®), Hot Mop, Lead Pan, Copper Pan, or Fiberglass
- Flow rate - 21 gpm per outlet
 - Flow rate measured at outlet only. Measurement does not account for water in channel or sheeting on shower floor.
 - Additional outlets can be added and combined into a larger waste line to increase flow rates

Installation

S Site Sizable Stainless Steel Channel

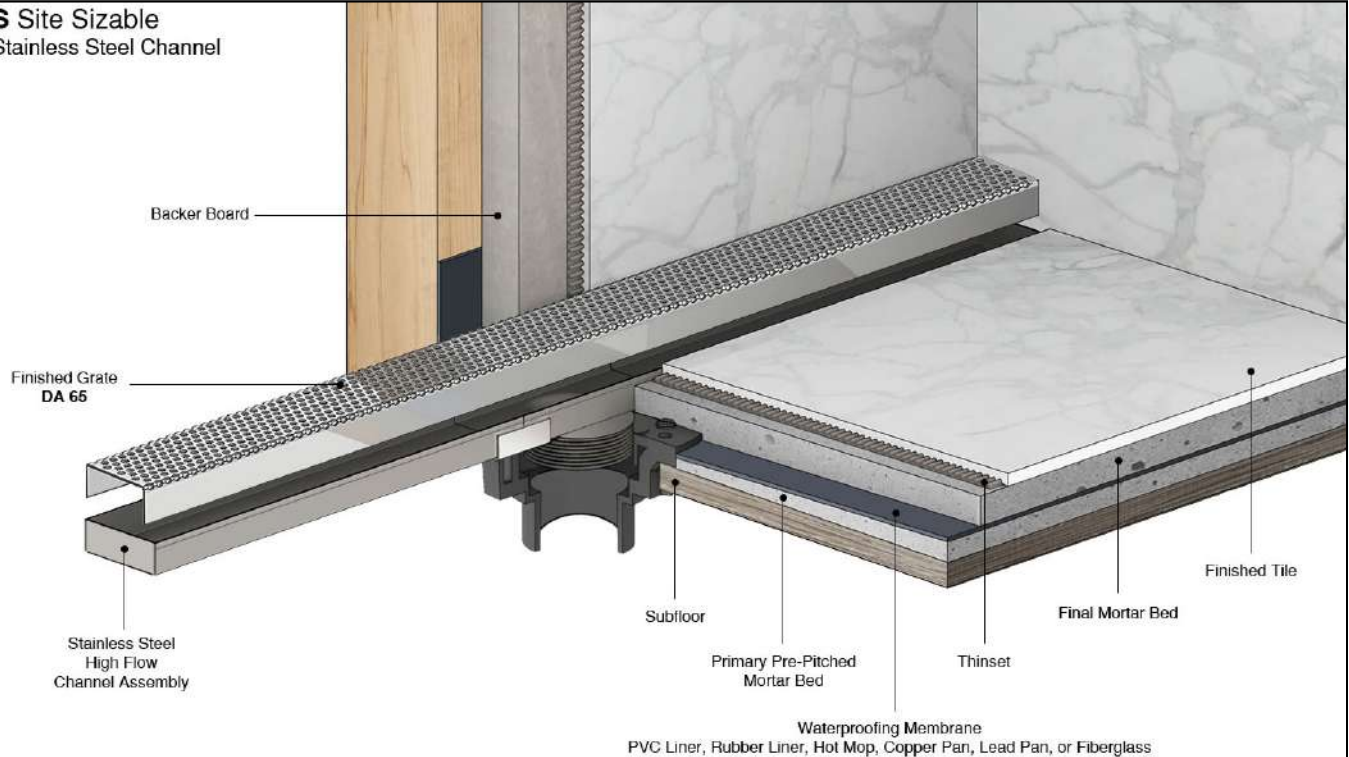

Care & Maintenance

S-DGAS 99 stainless steel linear drain top grates are made of 304L stainless steel. This material is non-porous, hygienic, rust-free and extremely durable. Bar Keepers Friend® and Soft Scrub® are commonly available products that can be used to protect and clean your Satin Stainless drain cover. For stains that have been left for an excessive amount of time, stronger cleaning agents such as Compound 302® may be needed. For Polished Stainless and Oil Rubbed Bronze we recommend a mild soap and a soft cloth for cleaning. DO NOT use any abrasive cleaners, scrub pads or allow household cleaning agents, such as bleach, to sit on the drain cover for a long period of time. Stainless steel does not rust. External factors, such as contamination from other highly ferrous metals, built up road salt, sea salt, or chlorine may have caused "surface" rust which can be removed using Barkeepers Friend®, Soft Scrub® with Bleach, or Compound 302®. Always follow the directions on the bottle. Follow proper maintenance procedures to prevent excessive surface rust. In areas of frequent exposure to salt, chlorine, and other chemical compounds, maintenance of the stainless grates should be performed at least 2-3 times per year.

Infinity Drain
18 Secatog Avenue
Port Washington, NY 11050
Phone: 516.767.6786
Fax: 516.740.3066
www.InfinityDrain.com



NOTE: Installer must verify all rough-in dimensions prior to installation and consult local and national codes. Conformity and compliance to local and national codes are the responsibility of the installer.

ID Infinity Drain

S-DGAS 9936

S-DGAS 9948

S-DGAS 9960

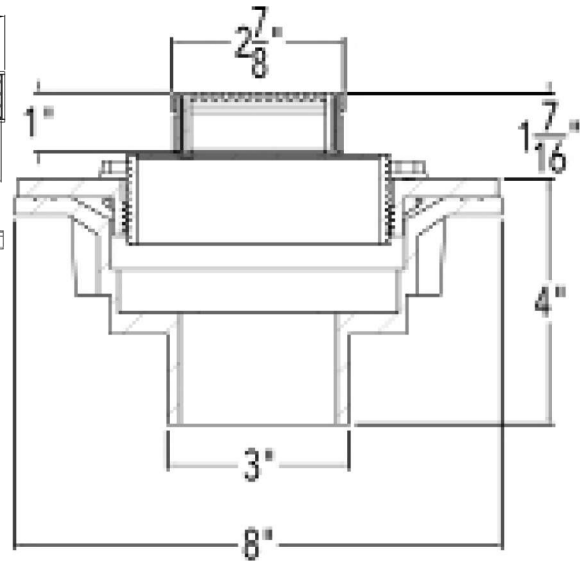
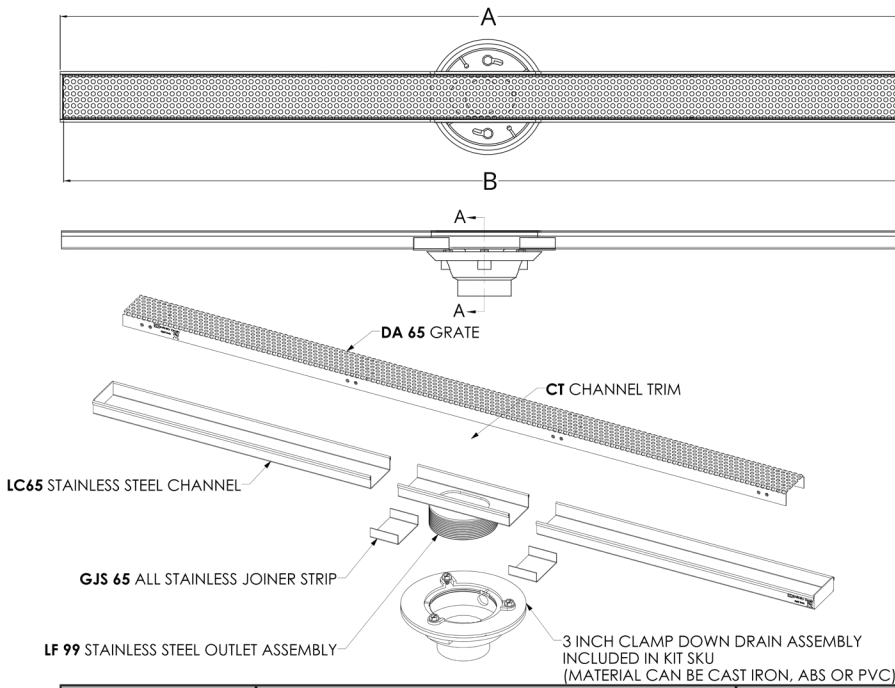

SECTION A-A

Model Number	Complete Kit Contents	A Maximum Overall Length	B Maximum Grate Length	C (Minimum Height Above Waterproofing) * All heights can be adjusted upwards an additional 1-1/4"
<input type="checkbox"/> S-DGAS 9936	1 - DA 6536 Stainless Steel Grate 1 - LC 6528 Stainless Steel Channel 1 - LF 99 8" Outlet Section Stainless Steel 2 - GJS 65 Stainless Steel Joiner Strip 1 - TNAS Threaded Nipple 1 - ZSIKA Sikaflex 1a Sealant 1 - HS 2 Hair Strainer 2 - CT 36 Channel Trim 1 - DKEY Lift Out Key	36"	35 7/8"	With CDI 43: 1 7/16" With CDA 43: 1 7/16" With CDP 43: 1 7/16"
<input type="checkbox"/> S-DGAS 9948	1 - DA 6548 Stainless Steel Grate 1 - LC 6540 Stainless Steel Channel 1 - LF 99 8" Outlet Section Stainless Steel 2 - GJS 65 Stainless Steel Joiner Strip 1 - TNAS Threaded Nipple 1 - ZSIKA Sikaflex 1a Sealant 1 - HS 2 Hair Strainer 2 - CT 48 Channel Trim 1 - DKEY Lift Out Key	48"	47 7/8"	With CDI 43: 1 7/16" With CDA 43: 1 7/16" With CDP 43: 1 7/16"
<input type="checkbox"/> S-DGAS 9960	1 - DA 6560 Stainless Steel Grate 1 - LC 6552 Stainless Steel Channel 1 - LF 99 8" Outlet Section Stainless Steel 2 - GJS 65 Stainless Steel Joiner Strip 1 - TNAS Threaded Nipple 1 - ZSIKA Sikaflex 1a Sealant 1 - HS 2 Hair Strainer 2 - CT 60 Channel Trim 1 - DKEY Lift Out Key	60"	59 7/8"	With CDI 43: 1 7/16" With CDA 43: 1 7/16" With CDP 43: 1 7/16"

Finishes

Satin Stainless

Polished Stainless

Infinity Drain
 18 Secatoag Avenue
 Port Washington, NY 11050
 Phone: 516.767.6786
 Fax: 516.740.3066
 www.InfinityDrain.com

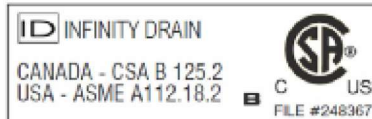

NOTE: Installer must verify all rough-in dimensions prior to installation and consult local and national codes. Conformity and compliance to local and national codes are the responsibility of the installer.

ID Infinity Drain

S-DGAS 9972

S-DGAS 9996

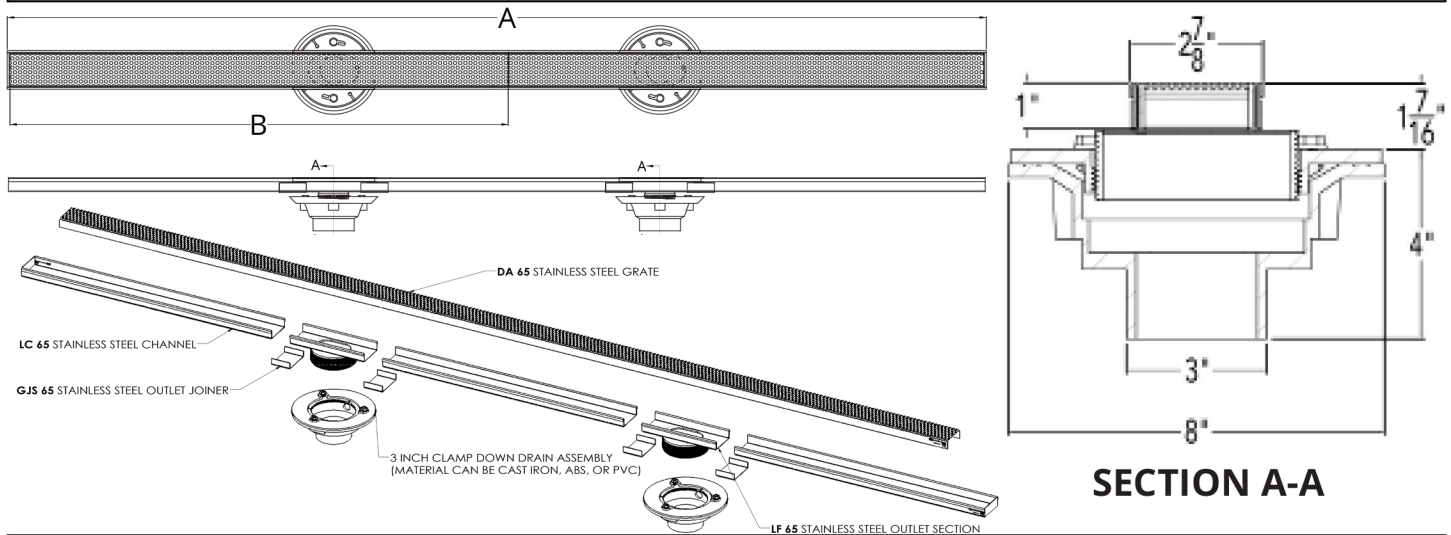

Model Number	Complete Kit Contents	A Maximum Overall Length	B Maximum Grate Length	C (Minimum Height Above Waterproofing) * All heights can be adjusted upwards an additional 1-1/4"
□ S-DGAS 9972	1 - DA 6572 Stainless Steel Grate 1 - LC 6564 Stainless Steel Channel 2 - LF 99 8" Outlet Section Stainless Steel 4 - GJS 65 Stainless Steel Joiner Strip 2 - TNAS Threaded Nipple 1- ZSIKA Sikaflex 1a Sealant 2 - HS 2 Hair Strainer 2 - CT 72 Channel Trim 1 - DKEY Lift Out Key	72"	35 7/8" (x 2)	With CDI 43: 1 7/16" With CDA 43: 1 7/16" With CDP 43: 1 7/16"
□ S-DGAS 9996	1 - DA 6596 Stainless Steel Grate 1 - LC 6588 Stainless Steel Channel 2 - LF 99 8" Outlet Section Stainless Steel 4 - GJS 65 Stainless Steel Joiner Strip 2 - TNAS Threaded Nipple 1- ZSIKA Sikaflex 1a Sealant 2 - HS 2 Hair Strainer 2 - CT 96 Channel Trim 1 - DKEY Lift Out Key	96"	47 7/8" (x 2)	With CDI 43: 1 7/16" With CDA 43: 1 7/16" With CDP 43: 1 7/16"

Optional Components	
UCP 4	Universal 4" Clamping Plate
TNRN-4	4" Cast Iron Extension Nipple
Add Clamp Down Drain	
CDA 42	Clamp Down Drain ABS
CDI 42	Clamp Down Drain Cast Iron
CDP 42	Clamp Down Drain PVC
CDA 43	Clamp Down Drain ABS
CDI 43	Clamp Down Drain Cast Iron
CDP 43	Clamp Down Drain PVC

Available components for longer lengths			
DA 6536	36" Stainless Steel Grate	SE 65	2" Stainless Steel End Section
DA 6548	48" Stainless Steel Grate	GJS 65	Stainless Steel Joiner Strip
DA 6560	60" Stainless Steel Grate	SLA 65	Stainless Steel 90° Angle Joiner
SC 6548	48" Stainless Open Ended Channel	LF 99	8" Stainless Steel Outlet Section
SC 6596	96" Stainless Open Ended Channel	CT 36	36" Channel Trim
LC 6528	28" Stainless Closed Channel	CT 48	48" Channel Trim
LC 6540	40" Stainless Closed Channel	CT 60	60" Channel Trim
LC 6552	52" Stainless Closed Channel	CT 72	72" Channel Trim
LC 6564	64" Stainless Closed Channel	CT 96	96" Channel Trim
LC 6588	88" Stainless Closed Channel		

Infinity Drain
 18 Secatoag Avenue
 Port Washington, NY 11050
 Phone: 516.767.6786
 Fax: 516.740.3066
 www.InfinityDrain.com



NOTE: Installer must verify all rough-in dimensions prior to installation and consult local and national codes. Conformity and compliance to local and national codes are the responsibility of the installer.