

1. Assembly the short bars and long bars onto the Shell

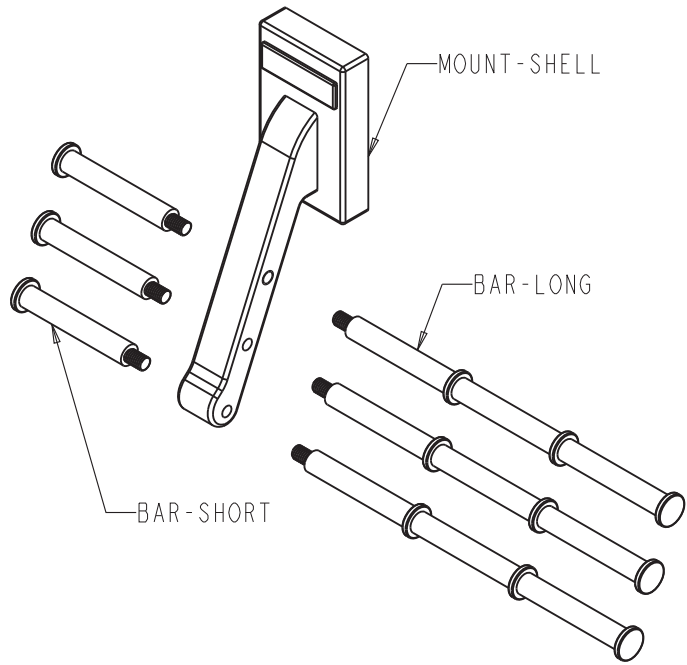

2. Mount the base onto flat surface

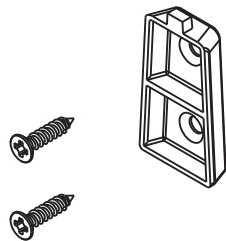

3. Slide the shell assembly onto the base

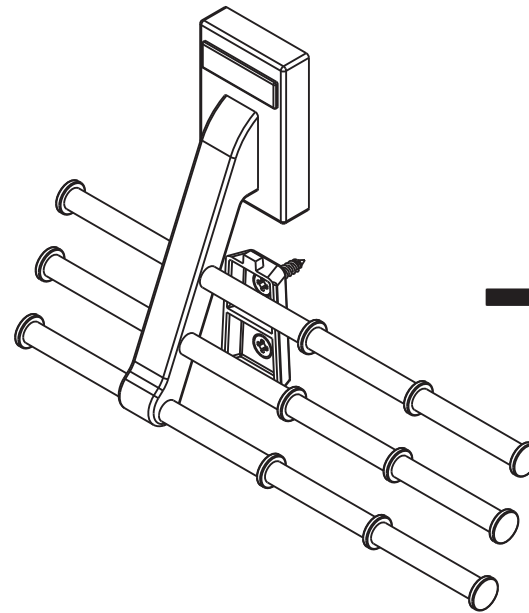

4. Mounting process finished

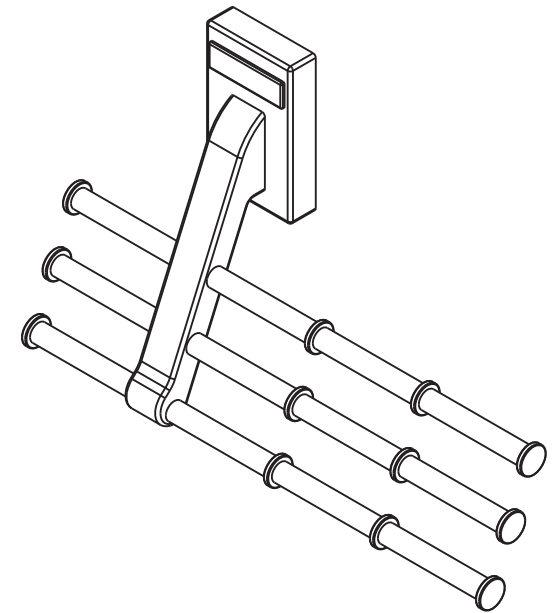

	ITEM:	TIE-RACK-X130606		MATERIAL:	ASSEMBLY
	FINISH:			WEIGHT:	255.94 g
PROPRIETARY AND CONFIDENTIAL THE INFORMATION CONTAINED IN THIS DRAWING IS THE SOLE PROPERTY OF HARDWARE RESOURCES INC. ANY REPRODUCTION IN PART OR AS A WHOLE WITHOUT THE WRITTEN PERMISSION OF HARDWARE RESOURCES INC. IS PROHIBITED.				PROJECTION	
TOLERANCE UNLESS OTHERWISE SPECIFIED:	UNITS:	DRAWN BY:	DATE:		
X ±0.20	SIZE:	APPROVED BY:	DATE:		
X.X ±0.10	A4				
X.XX ±0.05	SHEET:	RELEASE LEVEL:	REVISION:		
ANGULAR: ±0.5°					
DO NOT SCALE DRAWING					

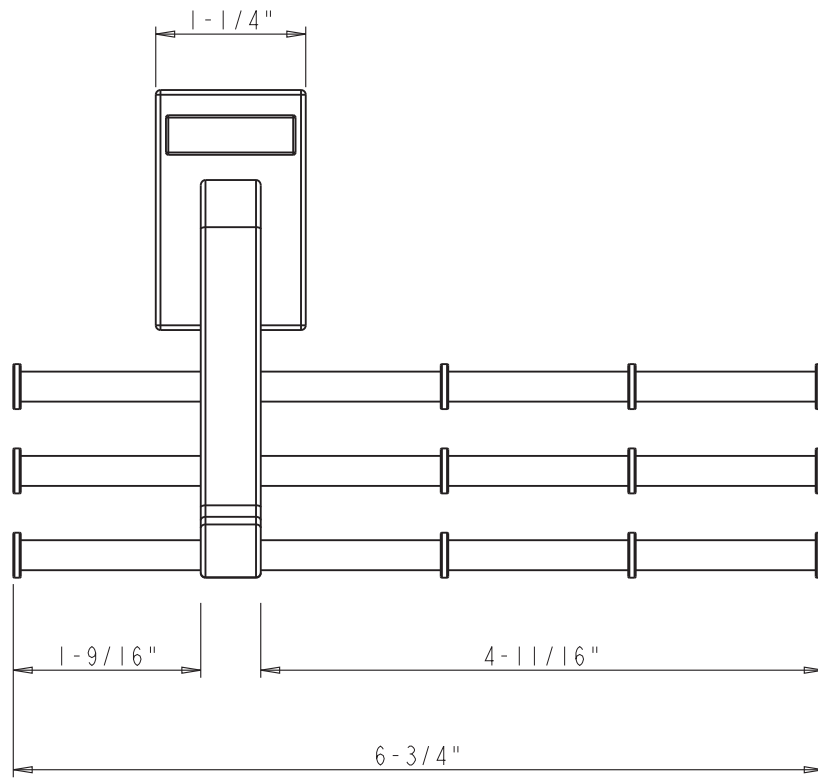

SEE DETAIL A

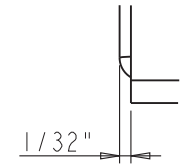
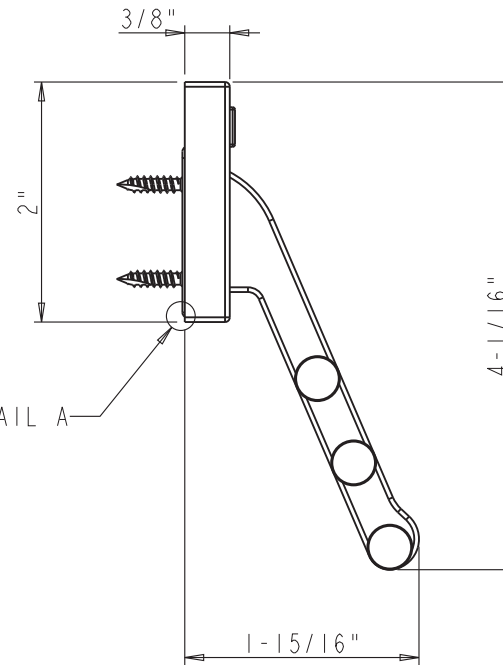

DETAIL A
SCALE 3:1

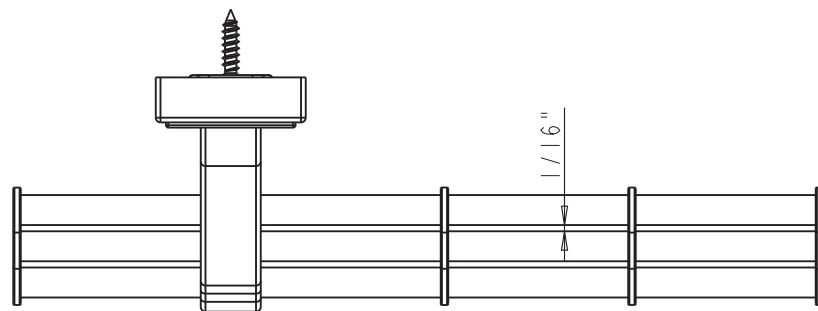

	ITEM:	TIE-RACK-X130606	MATERIAL:
	FINISH:		WEIGHT:
PROPRIETARY AND CONFIDENTIAL THE INFORMATION CONTAINED IN THIS DRAWING IS THE SOLE PROPERTY OF HARDWARE RESOURCES INC. ANY REPRODUCTION IN PART OR AS A WHOLE WITHOUT THE WRITTEN PERMISSION OF HARDWARE RESOURCES INC. IS PROHIBITED.	TOLERANCE UNLESS OTHERWISE SPECIFIED: X ±0.20 X.X ±0.10 X.XX ±0.05 ANGULAR: ±0.5°	UNITS: SIZE: A4 SHEET:	DRAWN BY: APPROVED BY: RELEASE LEVEL: DATE: DATE: REVISION:
DO NOT SCALE DRAWING			PROJECTION

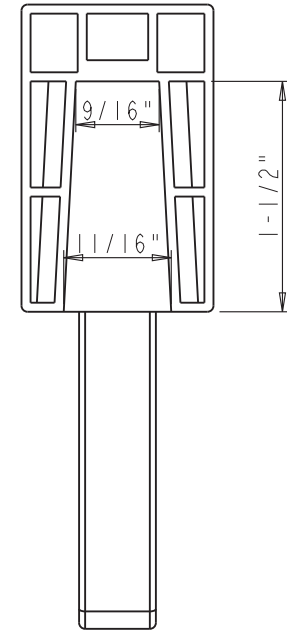
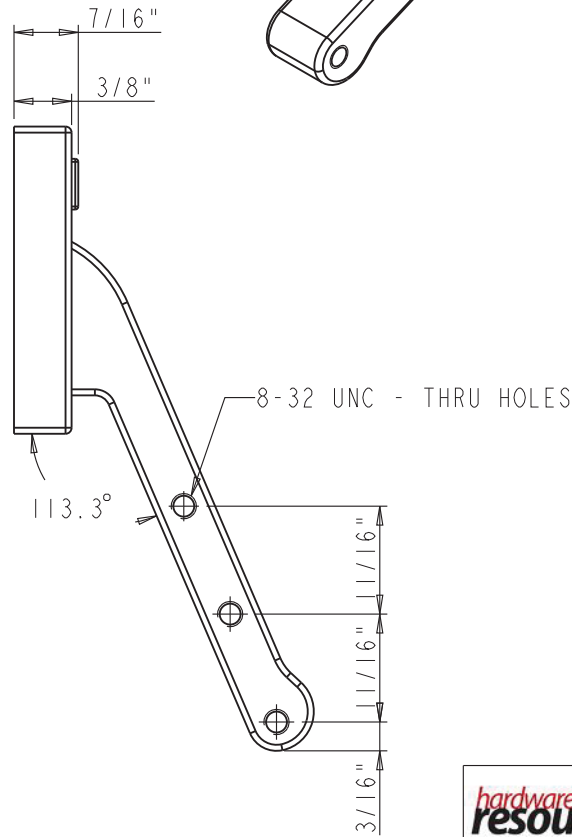
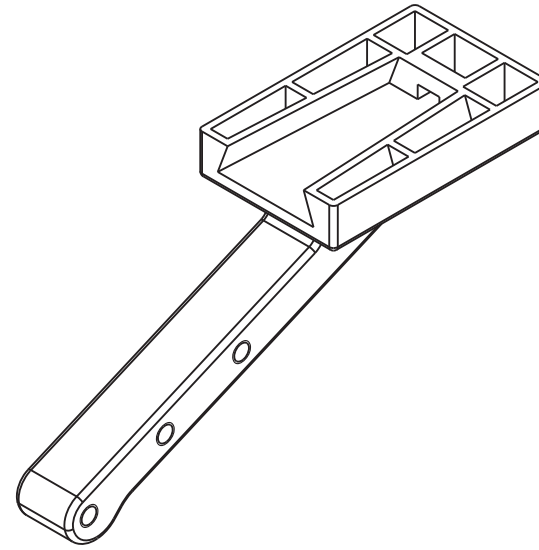
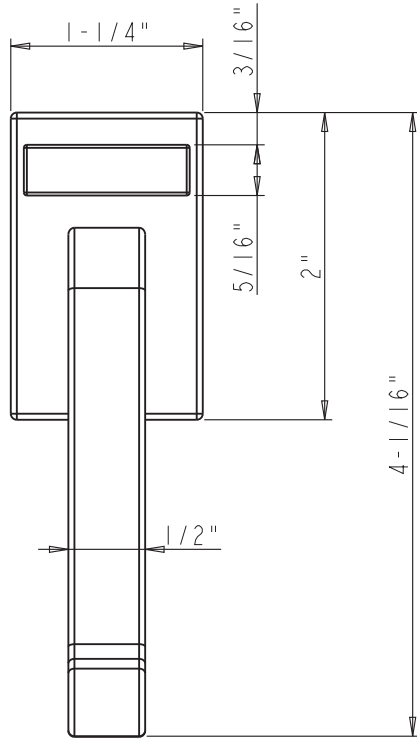
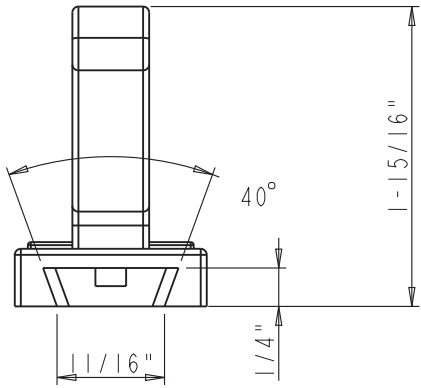

	ITEM#: MOUNT-SHELL		MATERIAL: Z1NC		
	FINISH:		WEIGHT: 116.30 g		
<p>PROPRIETARY AND CONFIDENTIAL</p> <p>THE INFORMATION CONTAINED IN THIS DRAWING IS THE SOLE PROPERTY OF HARDWARE RESOURCES INC. ANY REPRODUCTION IN PART OR AS A WHOLE WITHOUT THE WRITTEN PERMISSION OF HARDWARE RESOURCES INC. IS PROHIBITED.</p>	TOLERANCE UNLESS OTHERWISE SPECIFIED:		UNITS:		
	X ±0.20		DRAWN BY:		
	X.X ±0.10		APPROVED BY:		
	X.XX ±0.05		DATE:		
ANGULAR: ±0.5°		SIZE: A4		DATE:	
DO NOT SCALE DRAWING		SHEET: 1 OF 1		REVISION:	
		RELEASE LEVEL:		DATE:	

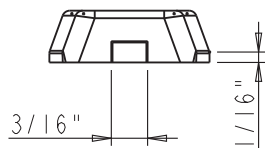
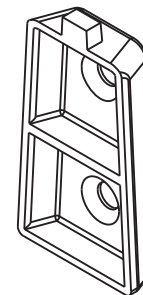
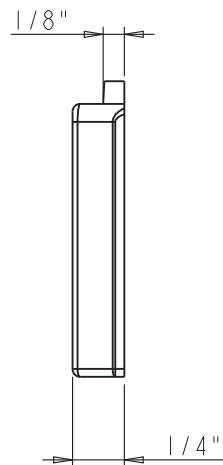
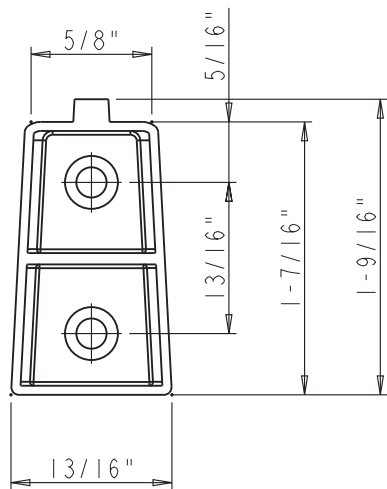

 PROPRIETARY AND CONFIDENTIAL THE INFORMATION CONTAINED IN THIS DRAWING IS THE SOLE PROPERTY OF HARDWARE RESOURCES INC. ANY REPRODUCTION IN PART OR AS A WHOLE WITHOUT THE WRITTEN PERMISSION OF HARDWARE RESOURCES INC. IS PROHIBITED.	ITEM#: MOUNT-BASE		MATERIAL: Zinc		
	FINISH:		WEIGHT: 11.945 g		
	TOLERANCE UNLESS OTHERWISE SPECIFIED: X ±0.20 X.X ±0.10 X.XX ±0.05 ANGULAR: ±0.5°		UNITS:	DRAWN BY: Alan Liu	DATE:
	DO NOT SCALE DRAWING		SIZE: A4	APPROVED BY:	DATE:
		SHEET:	RELEASE LEVEL:	REVISION:	

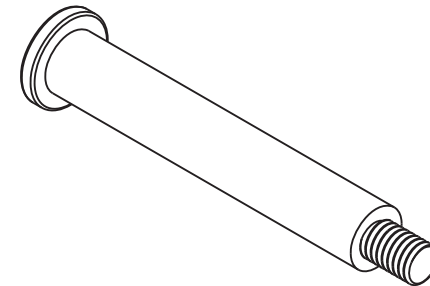
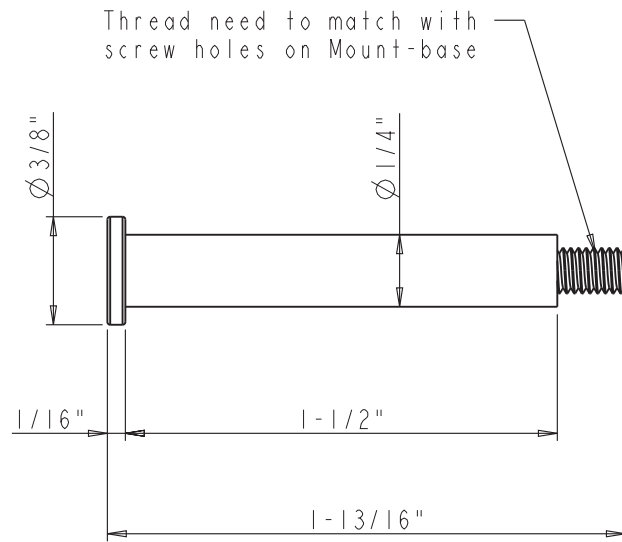

 PROPRIETARY AND CONFIDENTIAL THE INFORMATION CONTAINED IN THIS DRAWING IS THE SOLE PROPERTY OF HARDWARE RESOURCES INC. ANY REPRODUCTION IN PART OR AS A WHOLE WITHOUT THE WRITTEN PERMISSION OF HARDWARE RESOURCES INC. IS PROHIBITED.	ITEM#: BAR-SHORT		MATERIAL: STEEL		
	FINISH:		WEIGHT: 10.76 g		
	TOLERANCE UNLESS OTHERWISE SPECIFIED: X ± 0.20 X.X ± 0.10 X.XX ± 0.05 ANGULAR: $\pm 0.5^\circ$		UNITS:	DRAWN BY:	DATE:
	DO NOT SCALE DRAWING		SIZE: A4	APPROVED BY:	DATE:
		SHEET: 1 OF 1	RELEASE LEVEL:	REVISION:	

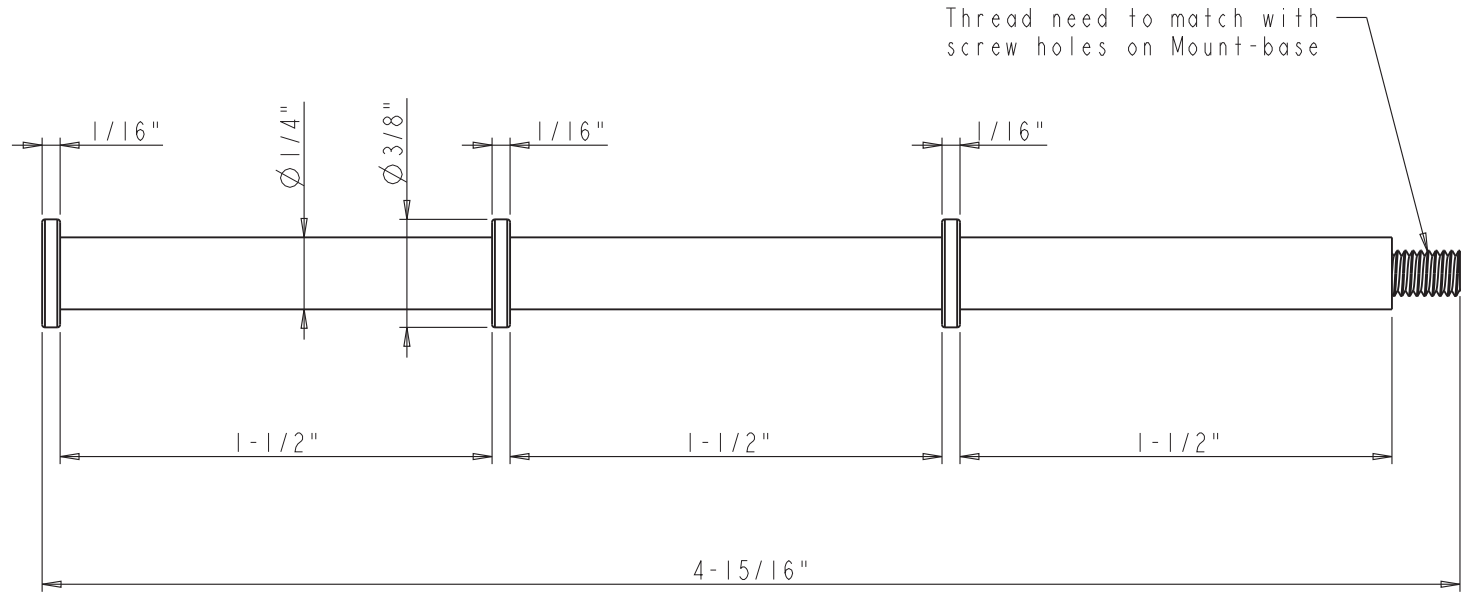

<p>hardware resources</p> <p>PROPRIETARY AND CONFIDENTIAL</p> <p>THE INFORMATION CONTAINED IN THIS DRAWING IS THE SOLE PROPERTY OF HARDWARE RESOURCES INC. ANY REPRODUCTION IN PART OR AS A WHOLE WITHOUT THE WRITTEN PERMISSION OF HARDWARE RESOURCES INC. IS PROHIBITED.</p>	ITEM#: BAR-LONG		MATERIAL: STEEL		
	FINISH:		WEIGHT: 31.34 g		
	TOLERANCE UNLESS OTHERWISE SPECIFIED: X ±0.20 X.X ±0.10 X.XX ±0.05 ANGULAR: ±0.5°		UNITS:	DRAWN BY:	DATE:
	DO NOT SCALE DRAWING		SIZE: A4	APPROVED BY:	DATE:
		SHEET: 1 OF 1	RELEASE LEVEL:	REVISION:	