

Comfort Series

SUBMITTAL DATA

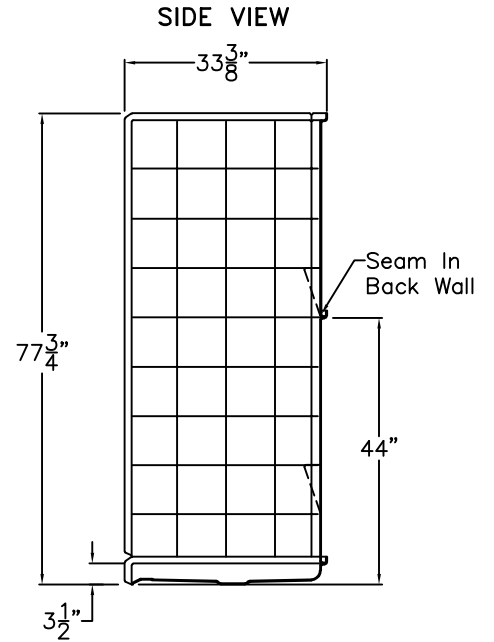

TOP VIEW

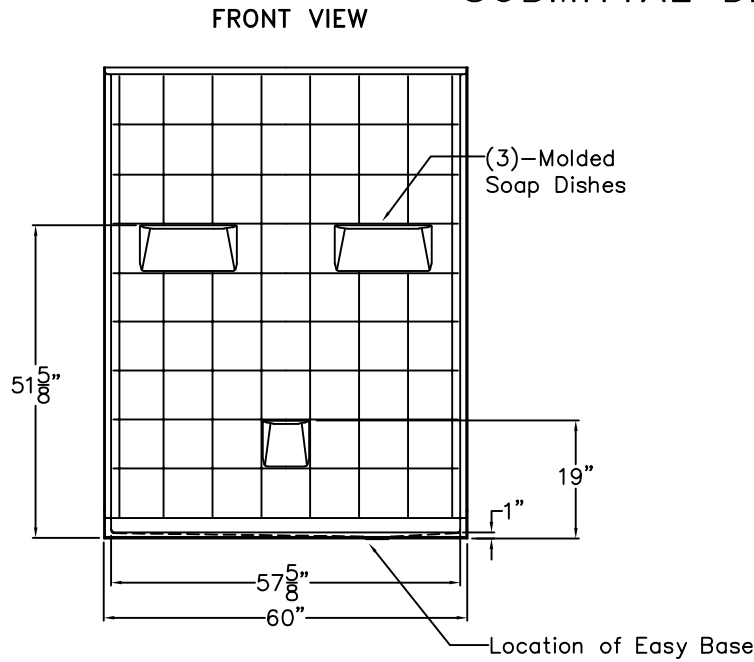
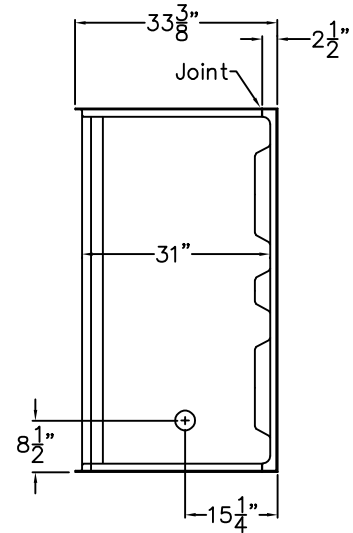

Sectional Shower

This shower enclosure shall be Model MP 6033 BF 5P 1.0 left or right drain location. Finished surface shall be of sanitary-grade applied acrylic. The unit shall have outside dimensions of 60" x 33 3/8" x 77 3/4". The unit shall meet IAPMO Z124-2011, and CSA B45.5-11.

The enclosure shall be equipped with the following factory installed accessories:

- 1) Molded soap ledges,
- 2) Molded lower ledge on back wall,
- 3) Tile finish,
- 4) Five piece sectional design,
- 5) Full reinforced backing on all walls,
- 6) Factory installed Armor Core Easy Base,
- 7) Left or right hand drain location,
- 8) 1.0" threshold.

Detail of 1.0" Threshold

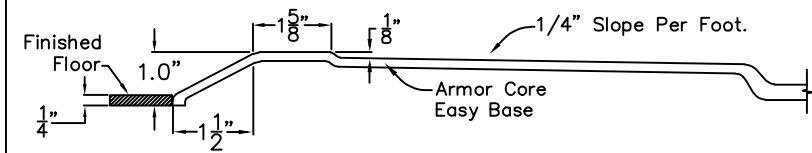

DUE TO THE NATURE OF THE MATERIALS INVOLVED
UNIT DIMENSIONS MAY VARY ± 1/2 INCH

Job Name:	PRAXIS	
Approved by Print Name:	Drawing#: MP 6033 BF 5P 1.0 L-R	
Approved by Signature:	Date:	Date: 8-31-10 Revised: 4-3-17
Rep.:	Wholesaler:	Quote No.

PRAXIS INDUSTRIES, INC.
ROUTE 1, BOX 46D - SAVANNAH, TN 38372
1 (800) 443-7269 - FAX (901) 925-4290

Recyclable Paper

Backing Placement Drawing

SUBMITTAL DATA

FRONT VIEW

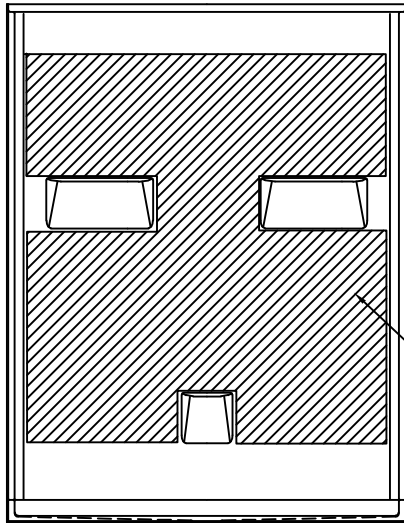

54" x 58"
Reinforced
Backing

SIDE VIEW

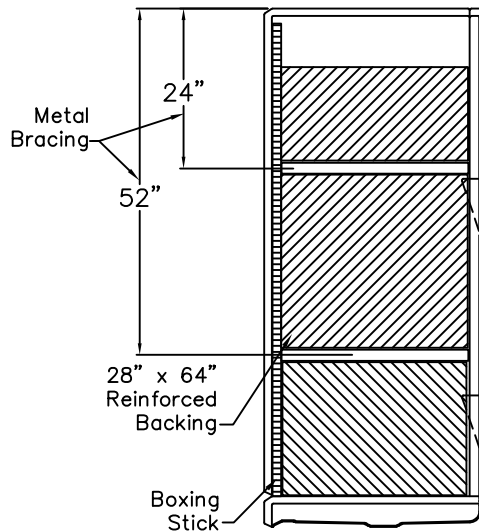

SIDE VIEW

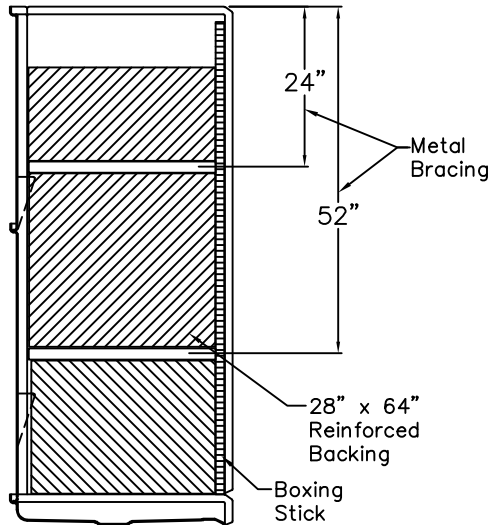

DUE TO THE NATURE OF THE MATERIALS INVOLVED
UNIT DIMENSIONS MAY VARY ± 1/2 INCH

Job Name:	PRAXIS		
Approved by Print Name:	Drawing#: MP 6033 BF 5P 1.0 L-R-BP		
Approved by Signature:	Date:	Date: 3-31-09	Revised: 4-3-17
Rep.:	Wholesaler:	Quote No.:	

PRAXIS INDUSTRIES, INC.
ROUTE 1, BOX 46D - SAVANNAH, TN 38372
1 (800) 443-7269 - FAX (901) 925-4290