

LUXURY ACRYLIC SERIES

SUBMITTAL DATA

FRONT VIEW

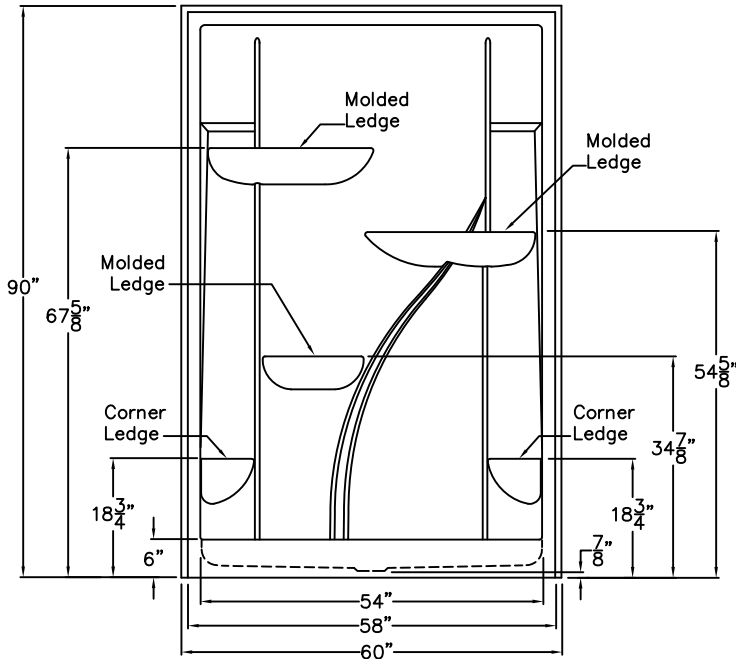

SIDE VIEW

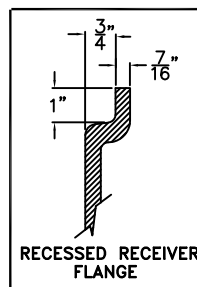
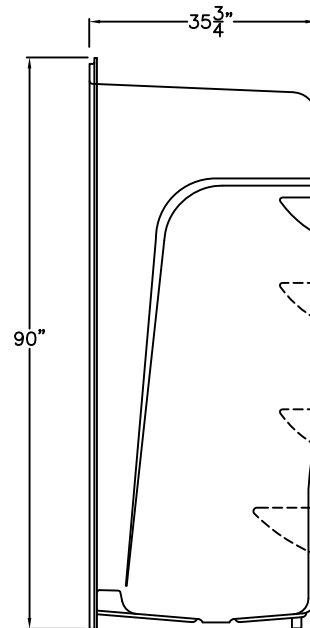

TOP VIEW

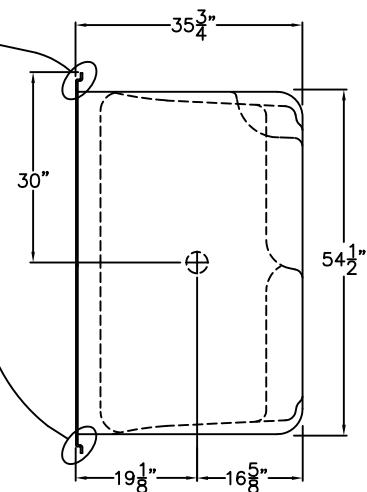

DUE TO THE NATURE OF THE MATERIALS
DIMENSIONS MAY VARY ± 1/2"

Acrylic Shower

This shower enclosure shall be model A6090 SH NS. Finished surface shall be of a sanitary grade thermoformed acrylic exhibiting a minimal thickness of 15 dry mils and a finished cured Barcoal hardness of 80-90 as tested with ASTM D-2583. Unit construction shall be of a molded reinforced fiberglass with a 15% minimum fiberglass content. The base shall be attached to the sump of the unit in such a manner to form an integral part with an inner and outer coating of reinforced polyester resin.

The unit shall have outside dimensions of 60" x 35 3/4" x 90".
The one piece shower shall meet ANSI Z124.1, ANSI Z124.1.2 and FHA/HUD-UM-73A.

The enclosure shall be equipped with the following accessories:

1. Acrylic Finish,
2. Center Drain Location,
3. Integral Top Dome,
4. Recessed Receiver Flanges On Sides And Across The Top,
5. Molded Corner Soap Ledge,
6. Molded Ledges On The Back Wall,
7. 6" Threshold,
8. Slip Resistant Bottom.

Job Name:		PRAXIS	
Approved By Print Name:		Drawing#: A6090 SH NS	
Approved By Signature:	Date Approved:	Date: 1-16-14	Revised: 6-22-16
Rep.:	Wholesaler:	Quote No.:	

PRAXIS INDUSTRIES, LLC.
435 INDUSTRIAL ROAD, SAVANNAH, TN 38372
1 (800) 443-7269 - FAX (731) 925-4290