

# LUXURY ACRYLIC SERIES

## SUBMITTAL DATA

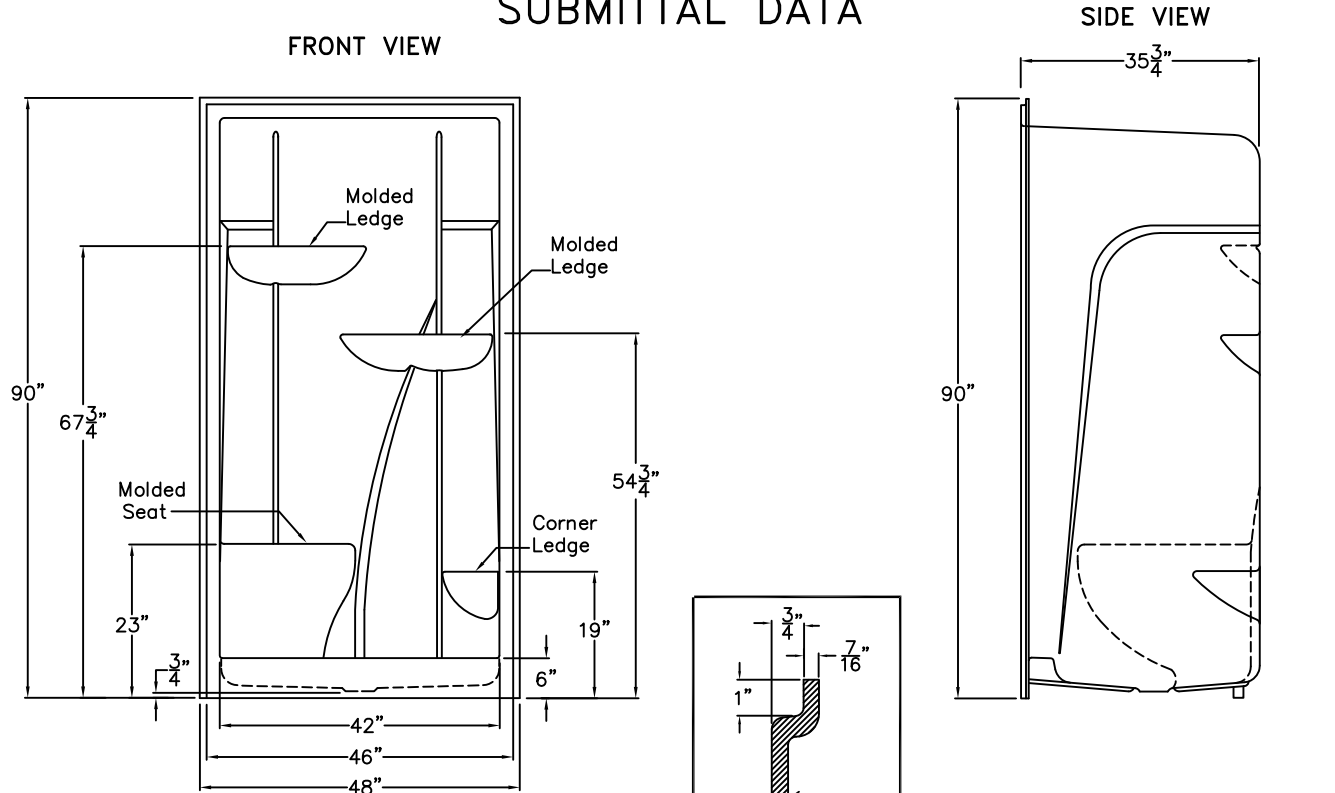

### Acrylic Shower

This shower enclosure shall be model A4890 SH 1S. Finished surface shall be of a sanitary grade thermoformed acrylic exhibiting a minimal thickness of 15 dry mils and a finished cured Barcoal hardness of 80-90 as tested with ASTM D-2583. Unit construction shall be of a molded reinforced fiberglass with a 15% minimum fiberglass content. The base shall be attached to the sump of the unit in such a manner to form an integral part with an inner and outer coating of reinforced polyester resin.

The unit shall have outside dimensions of 48" x 35 3/4" x 90".  
 The one piece shower shall meet ANSI Z124.1, ANSI Z124.1.2 and FHA/HUD-UM-73A.

The enclosure shall be equipped with the following accessories:

1. Acrylic Finish,
2. Center Drain Location,
3. Molded Seat Left Or Right,
4. Integral Top Dome,
5. Recessed Receiver Flanges On Sides And Across The Top,
6. Molded Corner Soap Ledge,
7. Molded Ledges On The Back Wall,
8. 6" Threshold,
9. Slip Resistant Bottom.

DUE TO THE NATURE OF THE MATERIALS  
 DIMENSIONS MAY VARY ± 1/2"

<b>Job Name:</b>		<b>PRAXIS</b>	
<b>Approved By Print Name:</b>		<b>Drawing#: A4890 SH 1S</b>	
<b>Approved By Signature:</b>	<b>Date Approved:</b>	<b>Date: 1-16-14</b>	<b>Revised: 5-11-16</b>
<b>Rep.:</b>	<b>Wholesaler:</b>	<b>Quote No.:</b>	

PRAXIS INDUSTRIES, LLC.  
 435 INDUSTRIAL ROAD, SAVANNAH, TN 38372  
 1 (800) 443-7269 - FAX (731) 925-4290