

Comfort Series

SUBMITTAL DATA

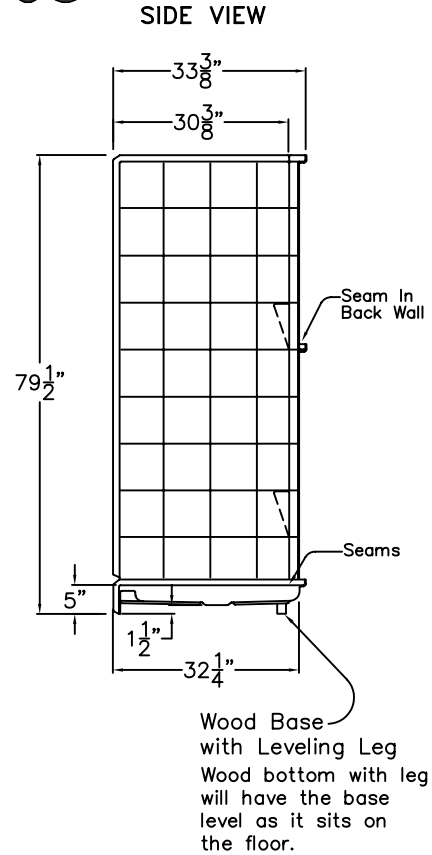
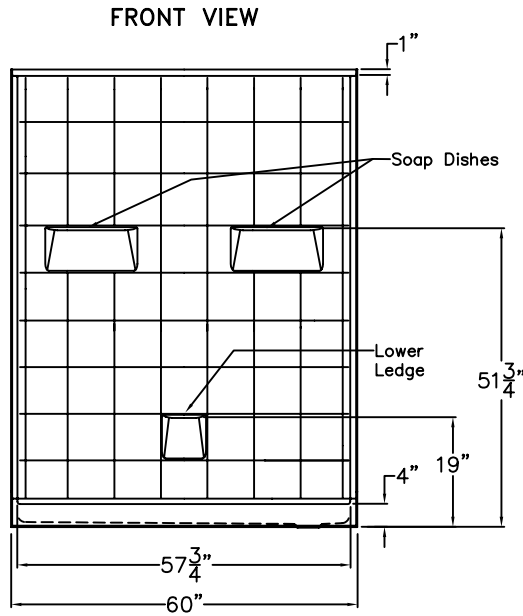

Sectional Shower Stall

The shower enclosure shall be MP 6033 SH 4.0" 5 Piece, Left or Right Drain. Finished surface shall be of a sanitary-grade polyester Gelcoat, exhibiting a minimal thickness of 15 dry mils, and a finished cured Barcol hardness of 80-90 as tested with ASTM D-2583. Unit construction shall be of molded reinforced fiberglass with a 15% minimum fiberglass content. The unit shall have outside dimensions of 60" x 33 3/8" x 79 1/2". The five piece unit shall meet ANSI Z124.2, NAHB, UPC, complies with CSA, and shall meet the requirements of Southern Building Code.

The enclosure shall be equipped with the following installed accessories:

- 1) Low Entry 4.0" Theshold, 2) Two Piece Back Wall,
- 3) Three Molded Soap Dishes on Back Wall, 4) Tile finish on walls,
- 5) Full wood backing on walls,
- 6) Factory installed Wood Base With Leveling Leg, Which Has The Base Level As It Sits On The Floor.
- 7) Left or Right drain location.

TOP VIEW

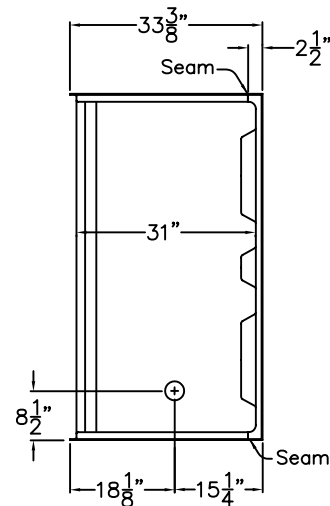

DUE TO THE NATURE OF THE MATERIALS INVOLVED
UNIT DIMENSIONS MAY VARY ± 1/2 INCH

Job Name:	PRAXIS		
Model No.:	Drawing#: MP 6033 SH 5P 4.0 Left or Right Drain FWB Leveling Leg		
Approved by:	Date Approved:	Date: 8-31-10	Revised: 5-9-12
Rep.:	Wholesaler:	Quote No.	

PRAXIS INDUSTRIES, INC.
ROUTE 1, BOX 46D - SAVANNAH, TN 38372
1 (800) 443-7269 - FAX (901) 925-4290

Recyclable Paper

Board Placement Drawing

SUBMITTAL DATA

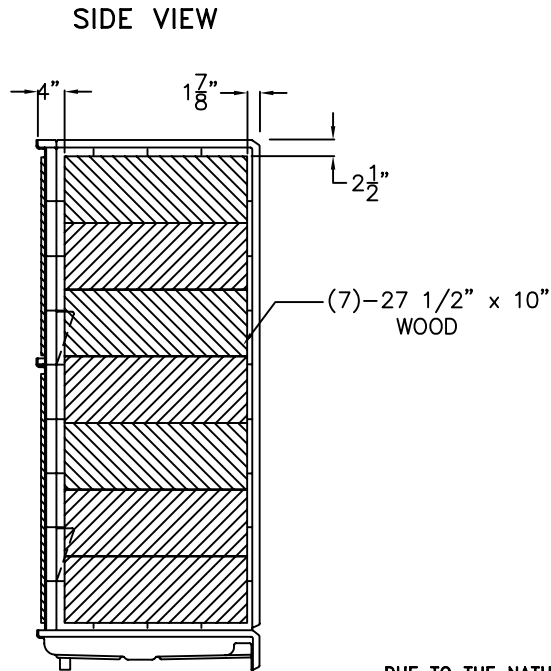
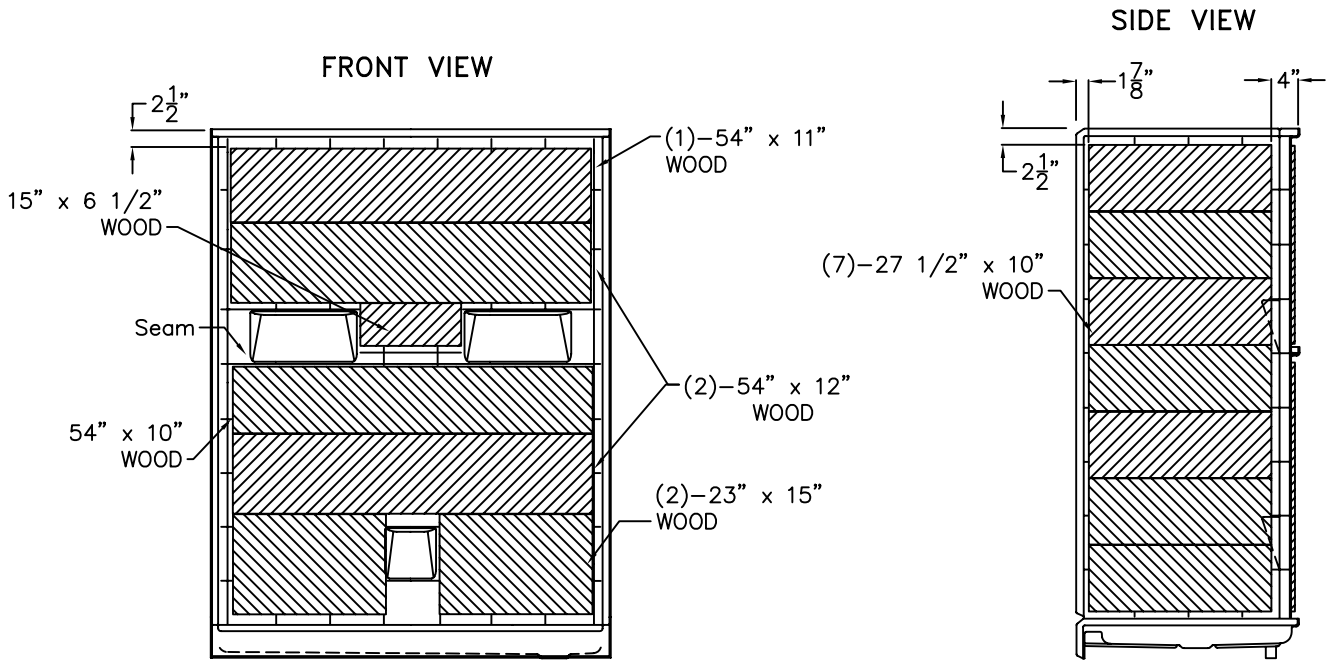

DUE TO THE NATURE OF THE MATERIALS INVOLVED
UNIT DIMENSIONS MAY VARY ± 1/2 INCH

Job Name:	PRAXIS		
Model No.:	Drawing#: MP 6033 SH 5P 4.0 Left or Right Drain FWB Leveling Leg-BP		
Approved by:	Date Approved:	Date: 3-31-09	Revised: 5-9-12
Rep.:	Wholesaler:	Quote No.:	

PRAXIS INDUSTRIES, INC.
ROUTE 1, BOX 46D - SAVANNAH, TN 38372
1 (800) 443-7269 - FAX (901) 925-4290