

# Luxury Acrylic Series

## SUBMITTAL DATA

FRONT VIEW

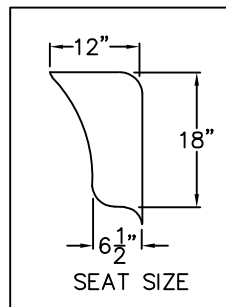
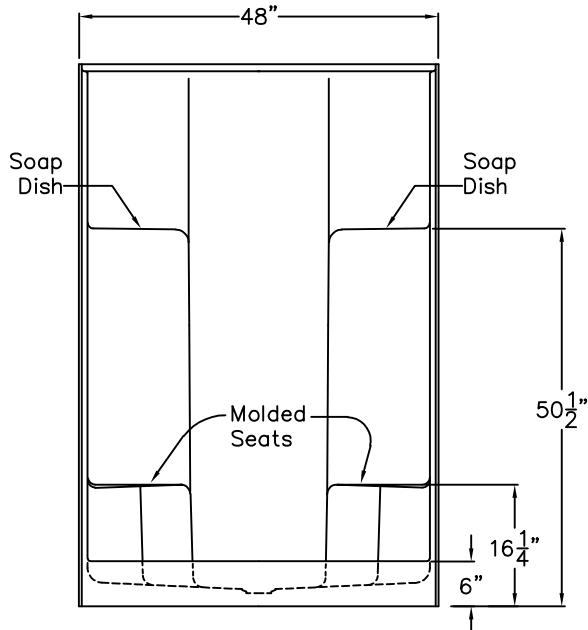

SIDE VIEW

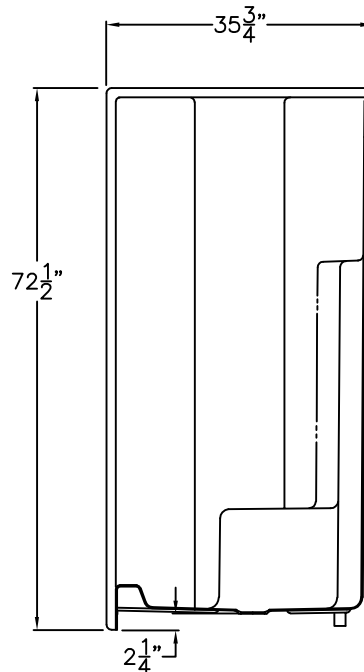

TOP VIEW

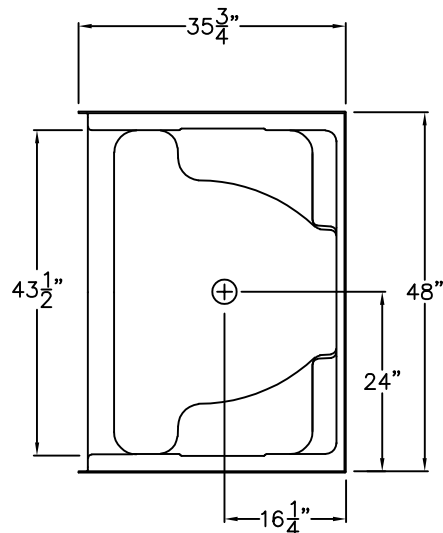

DUE TO THE NATURE OF THE MATERIALS  
DIMENSIONS MAY VARY ± 1/2"

### Smooth Wall Shower

This shower enclosure shall be Hamilton Model SG 4895 SH 2S center drain. Finished surface shall be of sanitary-grade applied acrylic. The unit shall have outside dimensions of 48" x 35 3/4" x 72 1/2". The unit shall meet IAPMO Z124-2011, and CSA B45.5-11.

The enclosure shall be equipped with the following factory installed accessories:

- 1) Molded corner soap dishes,
- 2) Two large molded seats,
- 3) Center drain,
- 4) 6.0" threshold.

Job Name:	HAMILTON
Approved By Print Name:	Drawing#: SG 4895 SH 2S
Approved By Signature:	Date: 5-18-07 Revised: 4-5-17
Rep.:	Quote No.:
Wholesaler:	

PRAXIS INDUSTRIES, LLC.  
435 INDUSTRIAL ROAD, SAVANNAH, TN 38372  
1 (800) 443-7269 - FAX (731) 925-4290