

Solid Surface Series SUBMITTAL DATA

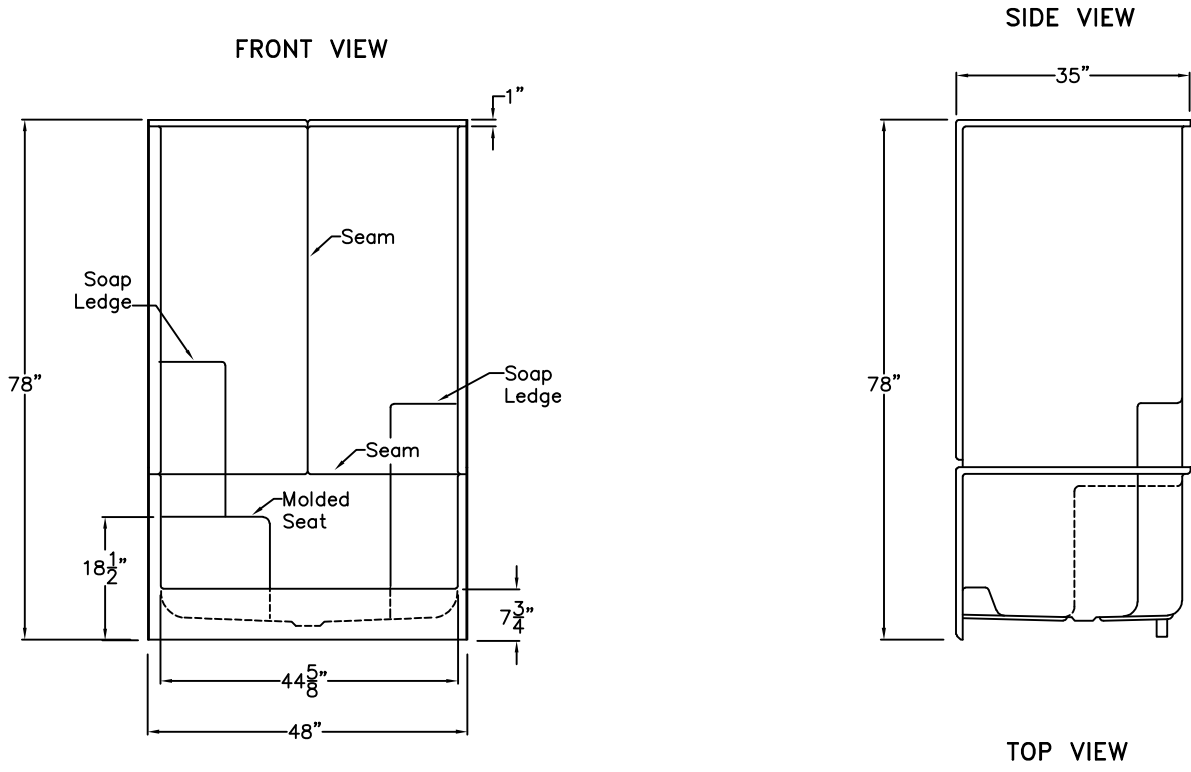

Sectional Shower
 This shower enclosure shall be Model STN 4887 SH 3P 1S right or left. Finished surface shall be of sanitary-grade solid surface. The unit shall have outside dimensions of 48" x 35" x 78". The unit shall meet IAPMO Z124-2011, and CSA B45.5-11.

The enclosure shall be equipped with the following factory installed accessories:

- 1) Molded corner soap ledges,
- 2) Molded seat
- 3) Three piece sectional design,
- 4) 7 3/4" threshold.

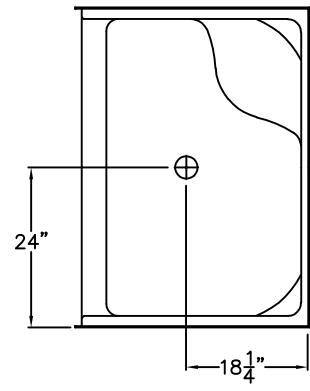

DUE TO THE NATURE OF THE MATERIALS
DIMENSIONS MAY VARY ± 1/2"

Job Name:	PRAXIS
Approved by Print Name:	Drawing#: G 4887 SH 3P 1S
Approved by Signature:	Date: 5-24-07 Revised: 4-7-17
Rep.:	Wholesaler: Quote No.:

PRAXIS INDUSTRIES, INC.
 435 INDUSTRIAL ROAD - SAVANNAH, TN 38372
 1 (800) 443-7269 - FAX (901) 925-4290