

# Comfort Series

SUBMITTAL DATA © 2002

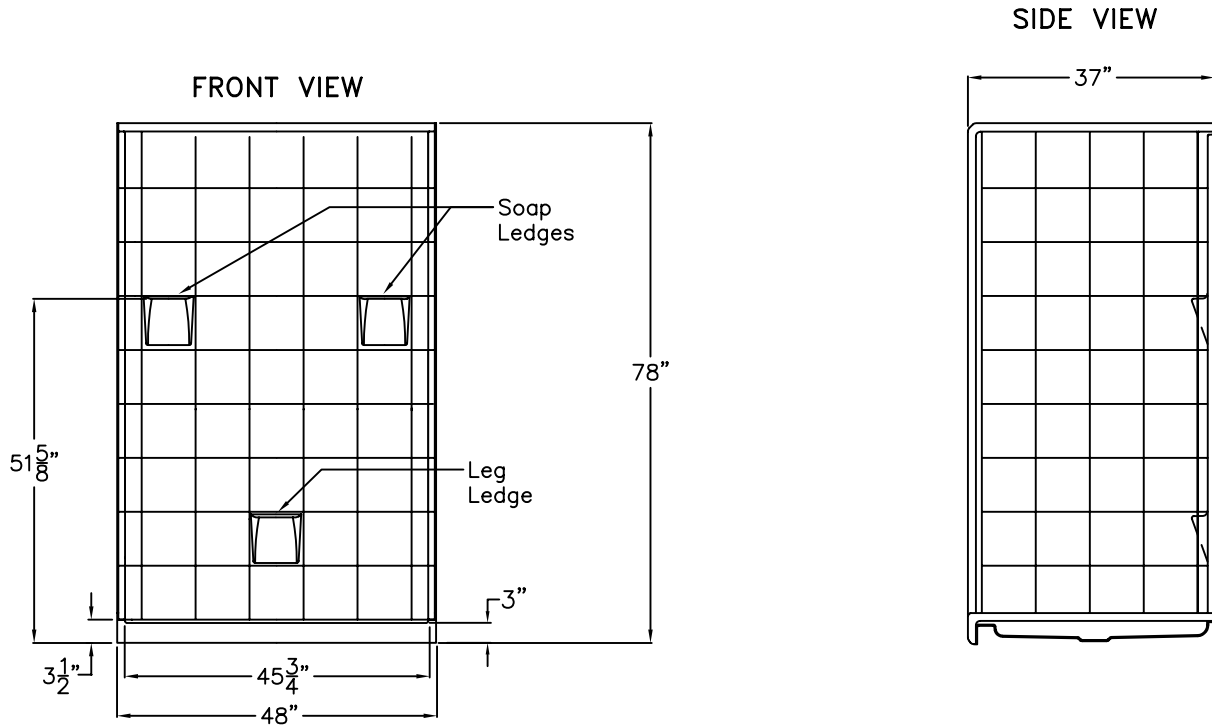

## Sectional Shower Stall

The shower enclosure shall be MP4836 SH 3.0" 4 Piece with center drain. Finished surface shall be of a sanitary-grade polyester Gelcoat exhibiting a minimal thickness of 15 dry mils, and a finished cured Barcol hardness of 80-90 as tested with ASTM D-2583. Unit construction shall be of molded reinforced fiberglass with a 15% minimum fiberglass content. The unit shall have outside dimensions of 48" x 37" x 78". The four piece unit shall meet ANSI Z124.2, NAHB, UPC, and shall meet the requirements of Southern Building Code.

The enclosure shall be equipped with the following installed accessories:

- 1) 3.0" Theshold, 2) Tile Finish, 3) Three Molded Soap Dishes on Back Wall, 4) Center drain location, 5) Full wood backing on all walls.

DUE TO THE NATURE OF THE MATERIALS INVOLVED  
UNIT DIMENSIONS MAY VARY ± 1/2 INCH

|              |                |                                |                  |
|--------------|----------------|--------------------------------|------------------|
| Job Name:    |                | HAMILTON                       |                  |
| Model No.:   |                | Drawing#: MP4836 SH 4P 3.0 FWB |                  |
| Approved by: | Date Approved: | Date: 3-31-09                  | Revised: 6-27-11 |
| Rep.:        | Wholesaler:    | Quote No.                      |                  |

PRAXIS INDUSTRIES, INC.  
ROUTE 1, BOX 46D - SAVANNAH, TN 38372  
1 (800) 443-7269 - FAX (901) 925-4290

Recyclable Paper

# Board Placement Drawing

SUBMITTAL DATA © 2004

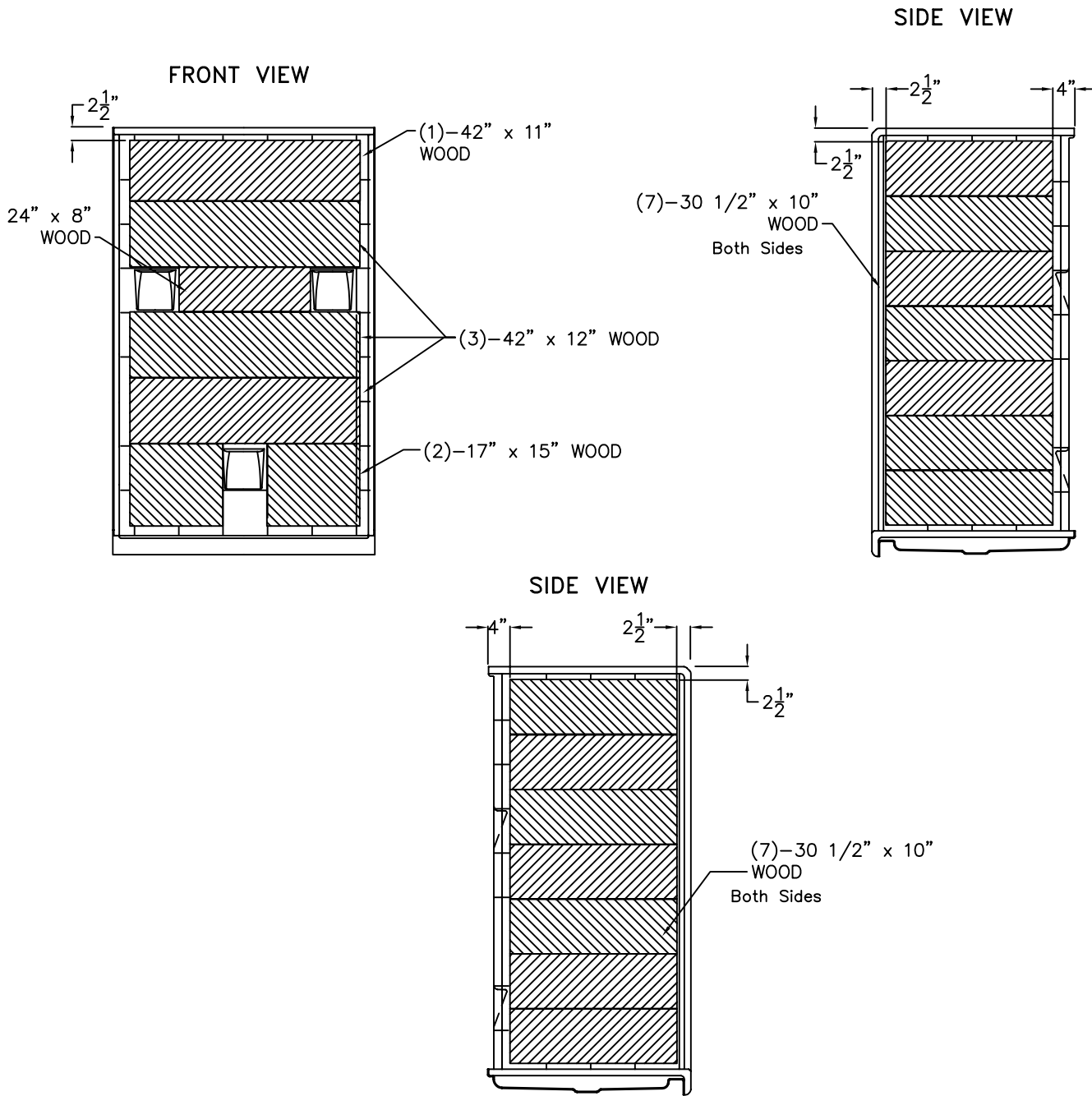

DUE TO THE NATURE OF THE MATERIALS INVOLVED  
UNIT DIMENSIONS MAY VARY ± 1/2 INCH

|              |                |                                   |                  |
|--------------|----------------|-----------------------------------|------------------|
| Job Name:    |                | HAMILTON                          |                  |
| Model No.:   |                | Drawing#: MP4836 SH 4P 3.0 FWB-BP |                  |
| Approved by: | Date Approved: | Date: 12-21-09                    | Revised: 6-27-11 |
| Rep.:        | Wholesaler:    | Quote No.:                        |                  |

PRAXIS INDUSTRIES, INC.  
ROUTE 1, BOX 46D - SAVANNAH, TN 38372  
1 (800) 443-7269 - FAX (901) 925-4290