

Comfort Series

SUBMITTAL DATA © 2002

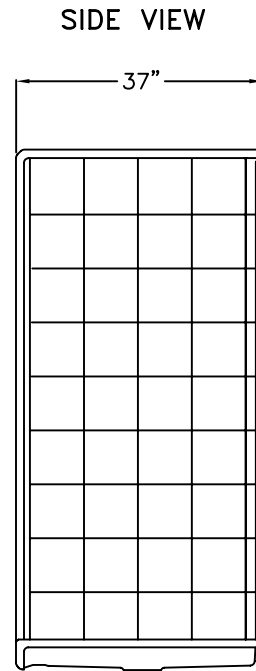
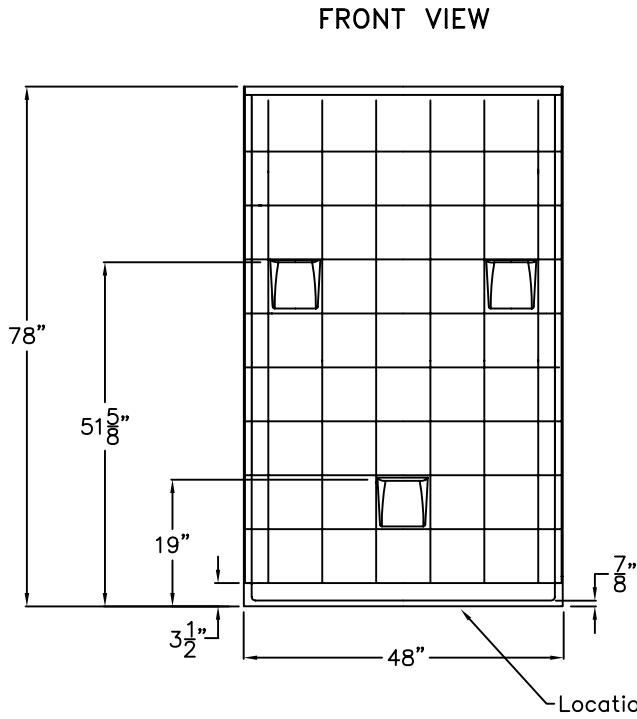

Sectional Shower Stall

The shower enclosure shall be MP 4836 BF 4P .875, center drain. Finished surface shall be of a sanitary-grade polyester Gelcoat exhibiting a minimal thickness of 15 dry mils, and a finished cured Barcol hardness of 80-90 as tested with ASTM D-2583. Unit construction shall be of molded reinforced fiberglass with a 15% minimum fiberglass content. The unit shall have outside dimensions of 48" x 37" x 78". The four piece unit shall meet ANSI Z124.2, NAHB, UPC, and shall meet the requirements of Southern Building Code.

The enclosure shall be equipped with the following installed accessories:

- 1) 1/2" thick oriented strand board full wood backing on the back wall,
- 2) 1/2" thick oriented strand board full wood backing on both side walls,
- 3) two molded soap dishes, 4) one lower leg ledge centered on back wall,
- 5) tile finish, 6) four piece design, 7) 7/8" Threshold,
- 8) Factory installed Easy Base self sustaining bottom.

TOP VIEW

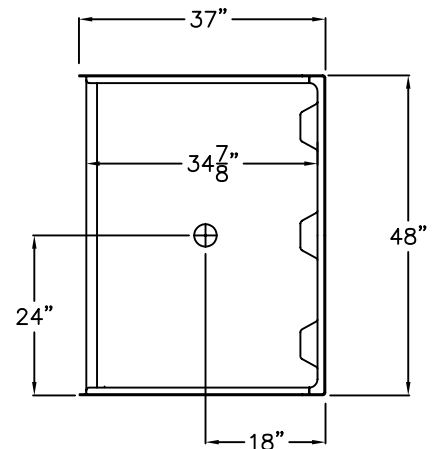

Detail of 7/8" Threshold

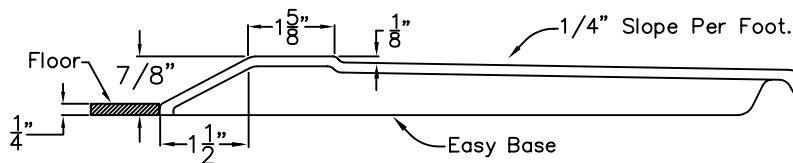

DUE TO THE NATURE OF THE MATERIALS INVOLVED
UNIT DIMENSIONS MAY VARY ± 1/2 INCH

HAMILTON

Model No.:

Drawing#: MP4836 BF .875 Bare FWB
Easy Base

Approved by:

Date Approved:

Date: 3-31-09

Revised: 8-29-11

Rep.:

Wholesaler:

Quote No.

PRAXIS INDUSTRIES, INC.
ROUTE 1, BOX 46D - SAVANNAH, TN 38372
1 (800) 443-7269 - FAX (901) 925-4290

Recyclable Paper

Board Placement Drawing

SUBMITTAL DATA © 2004

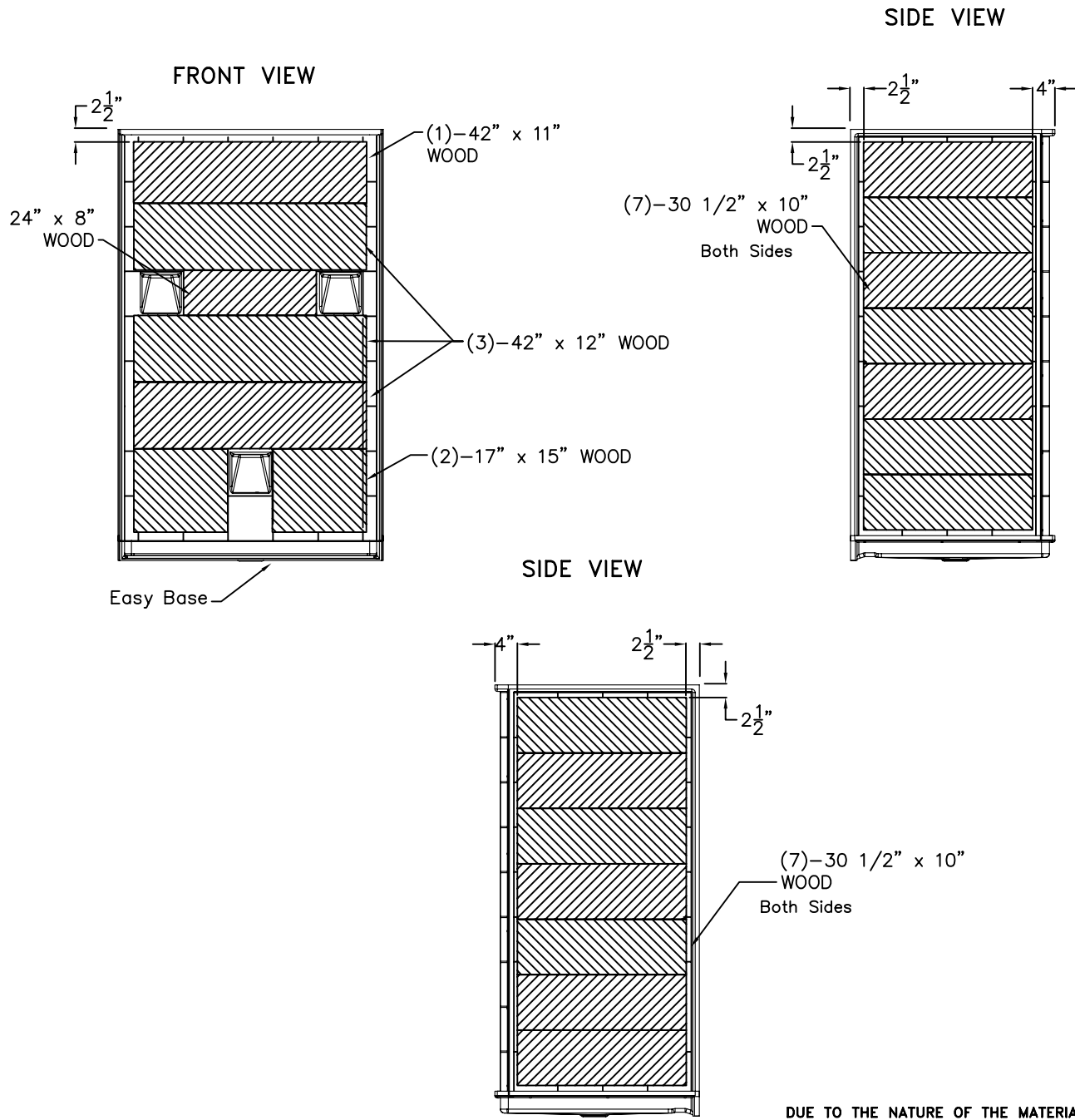

DUE TO THE NATURE OF THE MATERIALS INVOLVED
UNIT DIMENSIONS MAY VARY ± 1/2 INCH

Job Name:	HAMILTON		
Model No.:	Drawing#: MP4836 BF .875 Bare FWB Easy Base-BP		
Approved by:	Date Approved:	Date: 3-31-09	Revised: 12-20-10
Rep.:	Wholesaler:	Quote No.:	

PRAXIS INDUSTRIES, INC.
ROUTE 1, BOX 46D - SAVANNAH, TN 38372
1 (800) 443-7269 - FAX (901) 925-4290