

# Café™ 30" Built-In Convection Double Wall Oven

CTD70DM2NS5

# CAFÉ

DISTINCT BY DESIGN™



## FEATURES & BENEFITS

Precision is the name of your cooking game - Confidently try new recipes and perfectly execute your favorites, using a smart system that automatically tracks progress, modifies temperatures and adjusts cook times

Brighten up life in the kitchen - Easily navigate wall oven settings using a stunning full color display that adds an unexpected touch of style to your kitchen

The perfect bake is now perfectly easy - Achieve unrivaled performance with the only system that delivers top-down true convection for consistent results on special occasion favorites like roasts, chicken, turkey and more

No preheat, no hassle - Save time with a variety of precision cooking modes that eliminate the need for preheating

Fried taste. Crisp texture. Less oil. - Make your favorite "fried" foods healthy, thanks to a mode that crisps without using oil for frying

Enjoy convenient temperature control from anywhere - Preheat while running errands or change oven temperatures while doing yard work with the Café Appliances Kitchen app

The oven rack that handles it all - Easily remove heavy dishes with a roller rack that is specially designed to glide smoothly and stay in the oven during the self-clean cycle, so you never have to handle cumbersome racks again

The perfect fit you've always dreamed of - When you're updating your kitchen, attention to detail is a priority. That's why Café wall ovens are guaranteed for an exact fit or Café Appliances will pay up to \$300 toward modifications.

## APPEARANCE

Color Appearance	Platinum
Oven Door Features	Big View Oven Window
Handle	Café Minimal Style; Brushed Stainless
Installation	Above Warming Drawer; Side-by-Side

## FEATURES

Configuration	Double Oven
Cooking System	True European Convection with Direct Air (Upper) True European Convection (Lower)
Oven Cleaning Type	Self-Clean with Steam Clean Option
Cleaning Time	Variable with Delay Clean Option
Oven Cooking Modes	Convection Bake; Convection bake Multi-Rack; Convection Broil Hi/Lo; Convection Roast; Thermal Bake; Thermal Broil Hi/Lo; Hot-Air Frying; Scan-to- cook; Keep Warm; Proof; Precision Cooking Modes
Self-Clean Oven Door Lock	Automatic
Control Type	7" Full Color LCD Screen
Oven Features	10-Pass Bake Element; 10-Pass Dual Broil Element; Closed Door Broiling
Oven Rack Features	2 Never Scrub Roller Rack; 2 Never Scrub Flat Rack; 6 Embossed Rack Positions per oven
Oven Control Features	12-Hour Shut-Off Capability; Audible Preheat Signal; Auto Recipe Conversion; C° or F° Programmable; Certified Sabbath Mode; Control Lock Capability; Cook Time; Delay Time; Electronic Clock & Kitchen Timer; Remote Enabled; Temperature Probe
WiFi Connect	Built-In
Connected Capabilities	Amazon Alexa; The Google Assistant; IFTTT; Nest; Drop; Innit
Cooking Technology	Convection
Oven Interior	2 Halogen Interior Oven Lights (Both Ovens); Black Gloss Finish; Hidden Bake

## CAPACITY

Capacity (Cu. Ft.)	5.0 Upper / 5.0 Lower
Total Capacity (cubic feet)	10.0 cu ft

## POWER / RATINGS

Amp Rating at 208V	40
Amp Rating at 240V	40
Bake Wattage	2850W
Broiler Wattage	4300W; Dual Element
Convection Wattage	2400W
KW Rating at 208V	6.8
KW Rating at 240V	9

## WEIGHTS & DIMENSIONS

Approximate Shipping Weight	278 lb
Net Weight	260 lb
Overall Height	53 in
Overall Width	29-3/4 in
Overall Depth	26-3/4 in
Cabinet Width	30 in
Cutout Dimensions (w x h x d) (in.)	28-1/2 x 51-13/16 x 23-1/2
Oven Interior Dimensions (lower)	25 x 17-3/8 x 20-1/4
Oven Interior Dimensions (upper)	25 x 17-3/8 x 20-1/4

## OPTIONAL ACCESSORIES

30" Never Scrub Roller Rack	UXWORXR30
Large Broiler Pan	WB48X10056
60" Replacement Electrical Conduit	WB18T10574
72" Replacement Electrical Conduit	WB18T10580

# Café™ 30" Built-In Convection Double Wall Oven

CTD70DM2NS5

# CAFÉ

DISTINCT BY DESIGN™

## WARRANTY

Parts warranty	Limited 1-year entire appliance
Labor warranty	Limited 1-year entire appliance
Warranty notes	See written warranty for full details

## DIMENSIONS AND INSTALLATION INFORMATION

Wall coverings, countertops and cabinets surrounding the wall oven must be able to withstand a temperature of up to 200°F (94°C).

If the cabinet in which the wall oven is installed does not have a solid bottom, two braces or runners must be installed to support the weight of the oven. The runners and braces must support up to 400 lbs (181 kg).

Door handle protrudes 3" from door face. Cabinets and drawers on adjacent 45° and 90° walls should be placed to avoid interference with the handle.

**ATTENTION INSTALLER:** Electric wall ovens are NOT approved for installation with a plug and receptacle. They must be hard wired into an approved junction box.

**IMPORTANT:** Before installing, consult installation instructions packed with product for current dimensional data.

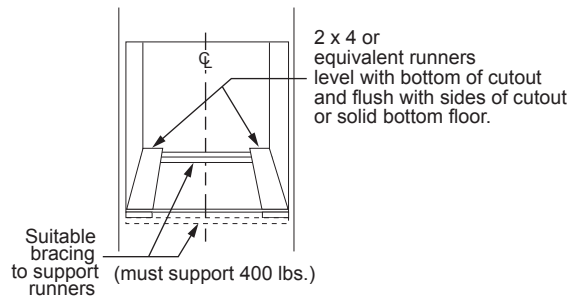
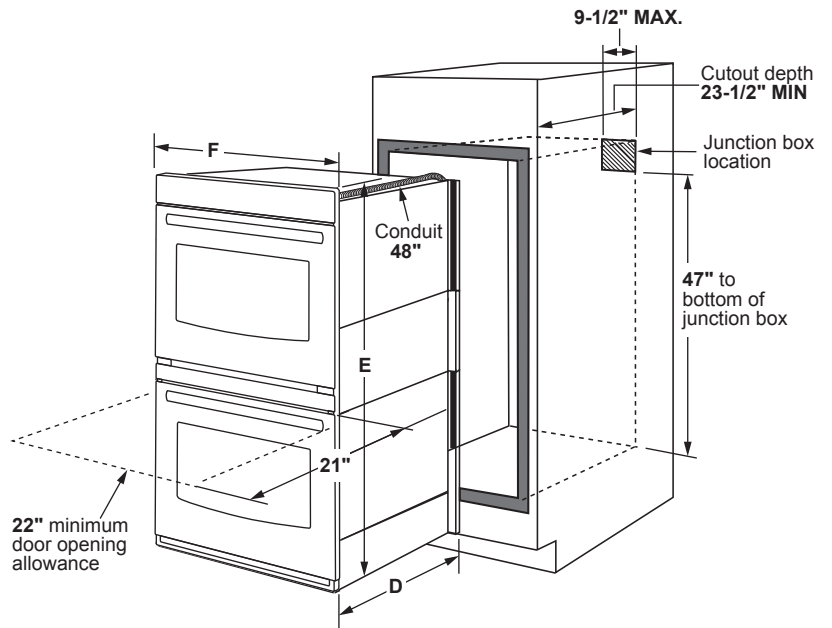
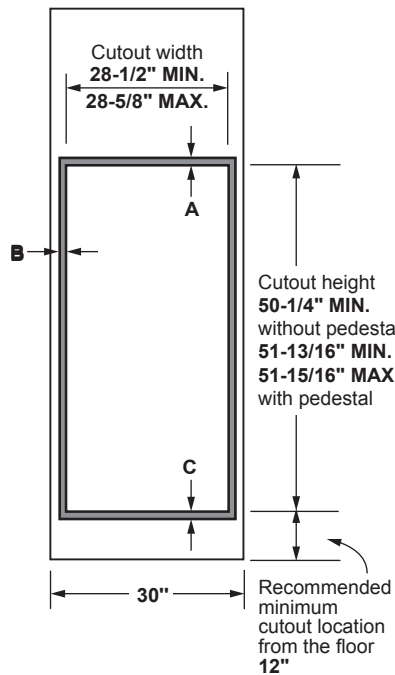

<b>Cabinet</b>	30"
A - Overlap of oven at top of cutout	1"
B - Overlap of oven other side of edge of cutout	3/4"
C - Overlap of oven at bottom of cutout	1-1/4"
<b>Oven</b>	
D - Install depth	23-1/2"
E - Overall height with trim	53"
F - Overall width	29-3/4"

Dimension and installation information are shown in inches.

# Café™ 30" Built-In Convection Double Wall Oven

CTD70DM2NS5

C A F É

DISTINCT BY DESIGN™

## DIMENSIONS AND INSTALLATION INFORMATION

30" Double electric wall ovens are approved for installation above 27" and 30" warming drawers.

**WHEN TO USE THE PEDESTAL RAILS:** When replacing an older GE Appliances 30" double wall oven with a new GE Appliances model. Cutout Height = 51-13/16" to 51-15/16". This is our traditional cutout height.

**WHEN NOT TO USE THE PEDESTAL RAILS:** When replacing a 30" double wall oven from another manufacturer (ie; Whirlpool) with a new GE Appliances model. Cutout height = 50-1/4". You will need to verify that the existing cutout matches the 50-1/4" dimension.

If the new GE Appliances 30" double wall oven is being installed into new construction (ie; not a replacement), then the recommended installation is to use the pedestal rails.

**ATTENTION INSTALLER:** Electric wall ovens are NOT approved for installation with a plug and receptacle. They must be hard wired into an approved junction box.

**IMPORTANT:** Before installing, consult installation instructions packed with ALL products for current dimensional and combination data.

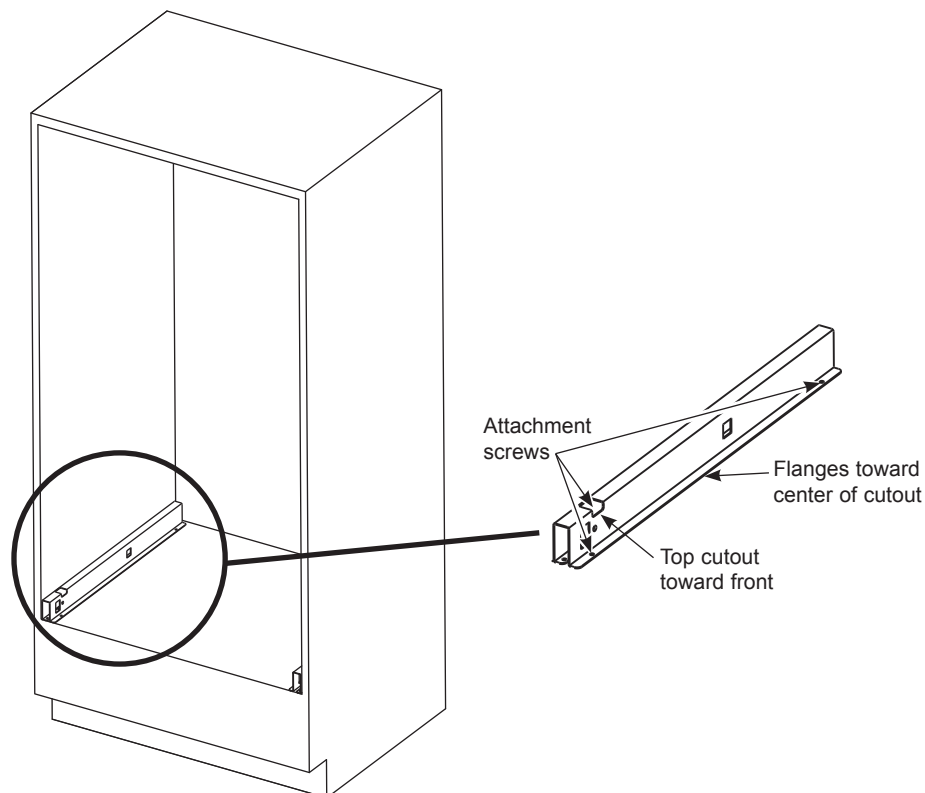

Dimension and installation information are shown in inches.

# Café™ 30" Built-In Convection Double Wall Oven

CTD70DM2NS5

# CAFÉ

DISTINCT BY DESIGN™

## FLUSH INSET DIMENSIONS AND INSTALLATION INFORMATION

### NOTES:

- A** Junction Box location (may also be located in an adjacent cabinet).
- B** Platform must be able to support 400 lbs (181 kg).
- C** Cabinet surfaces must be an appearance finished surface for flush installation.
- D** Cleats may be visible and should be finished to match cabinetry.

**ATTENTION INSTALLER:** Electric wall ovens are NOT approved for installation with a plug and receptacle. They must be hard wired into an approved junction box.

**IMPORTANT:** Before installing, consult installation instructions packed with ALL products for current dimensional and combination data.

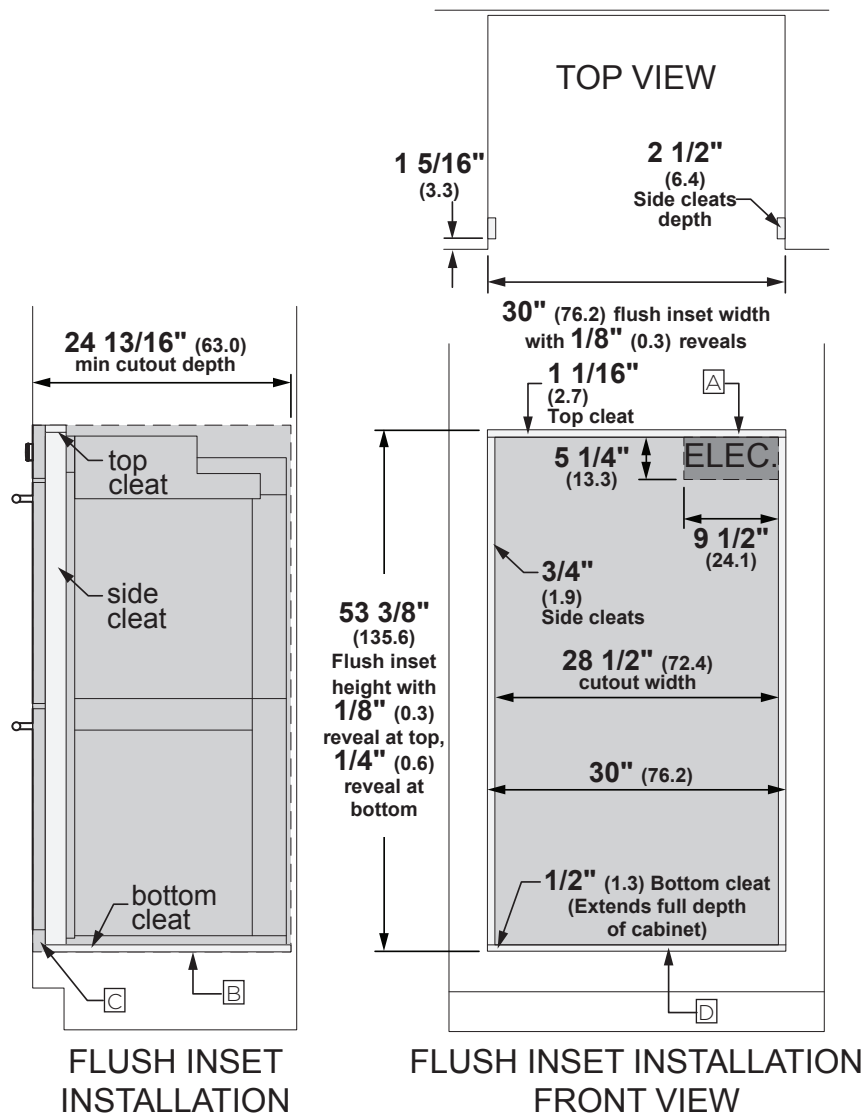

Allow 1/8" (0.3) clearances from side edges of oven door.

Dimension and installation information are shown in inches.