

Features:

GHE21310

Included Components:

- Combination GHE21310
- Bowl GHE21374
- Tank GHE28380

- Vitreous China
- 4-1/4" vertical Rough-in
- 2" Flushmate® Pressure flush valve for maximum water force
- Extra-Large Dual fed siphon jets for high power bowl clearing
- 100% glazed, 2" trapway
- Double nut, multi-point tank-to-bowl mounting system for tool-free installation
- Chrome, metal front tank lever
- Toilet seat is not included



Technical Information:

Configuration	Two-Piece, Elongated Back Outlet Toilet
Water per Flush	1.28 GPF (4.8 LPF)
Rough-In	4 1/4"
Height	28 3/4"
Width	20"
Depth	30 5/16"
Trapway	2"
Large Water Surface	8 11/16" x 6 5/16"
Shipping weight Bowl	60.2 lbs
Shipping weight Tank	44.3 lbs

Accessories: (To be purchased separately)

N/A

Other Tank Options: (To be purchased separately)

- Tank with Lid Locking Device GHE28380LL
- Tank with Right Hand Lever GHE2838097

Available Colors:

- White
- Other: Refer to Price Book for additional colors/finishes

Warranty:

- Limited Lifetime on Vitreous China, refer to the website for more details.

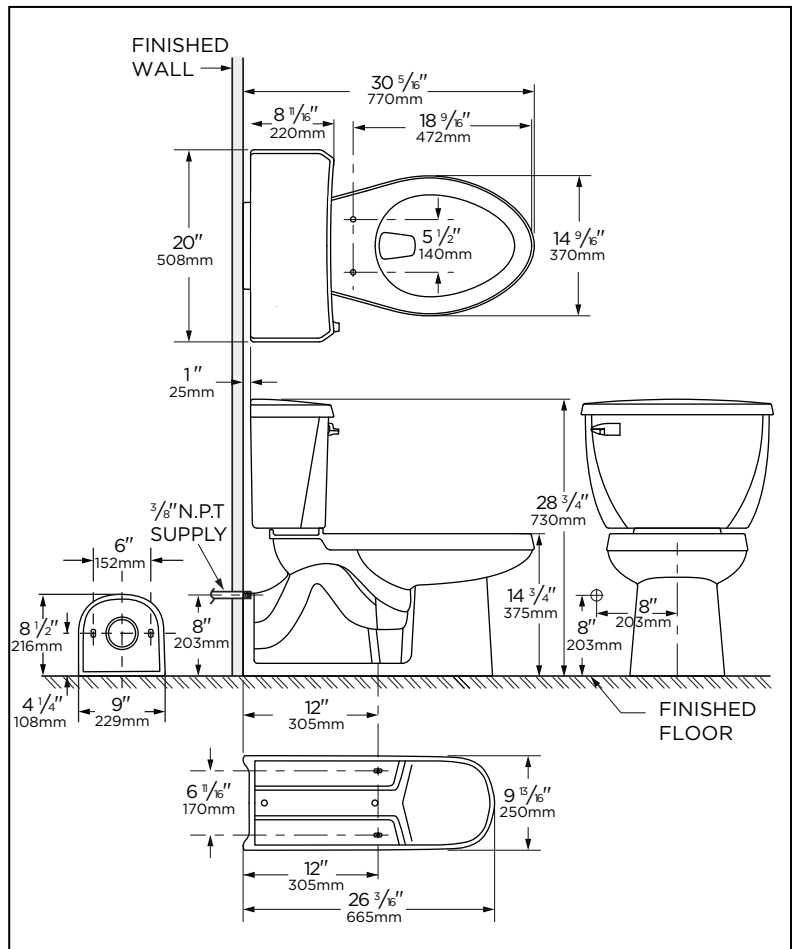

NOTES: All dimensions are in inches and millimeters. Illustrations may not be drawn to scale.

IMPORTANT:

Dimensions of fixtures are nominal and may vary within the range of tolerances established by ASME standard A 112.19.2 THIS FIXTURE QUALIFIES ACCORDING TO ASME TEST PROCEDURES AS A HIGH EFFICIENCY WATER CLOSET WITH AN AVERAGE CONSUMPTION OF 1.28 gpf (4.8 Lpf) OR LESS.