

**Features:**

**GHE20302**

Included Components:

- Combination      GHE20302
- Bowl                GUF21342
- Tank                 GHE28380

- Vitreous China
- 12" Rough-in
- 2" Flushmate® Pressure flush valve for maximum water force
- Extra-Large Dual fed siphon jets for high power bowl clearing
- 100% glazed, 2" trapway
- Double nut, multi-point tank-to-bowl mounting system for tool-free installation
- Chrome, metal front tank lever
- Toilet seat is not included



**Technical Information:**

Configuration	Two-piece Round Front Toilet
Water per Flush	1.28 GPF (4.8 LPF)
Rough-In	12"
Height	28 1/2"
Width	20"
Depth	27 11/16"
Trapway	2"
Large Water Surface	8 11/16" x 6 5/16"
Shipping weight Bowl	47.8 lbs
Shipping weight Tank	44.3 lbs

**Accessories:** (To be purchased separately)

N/A

**Other Tank Options:** (To be purchased separately)

- Tank with Lid Locking Device      GHE28380LL
- Tank with Right Hand Lever      GHE2838097

**Available Colors:**

- White
- Other: Refer to Price Book for additional colors/finishes

**Warranty:**

- Limited Lifetime on Vitreous China, refer to the website for more details.

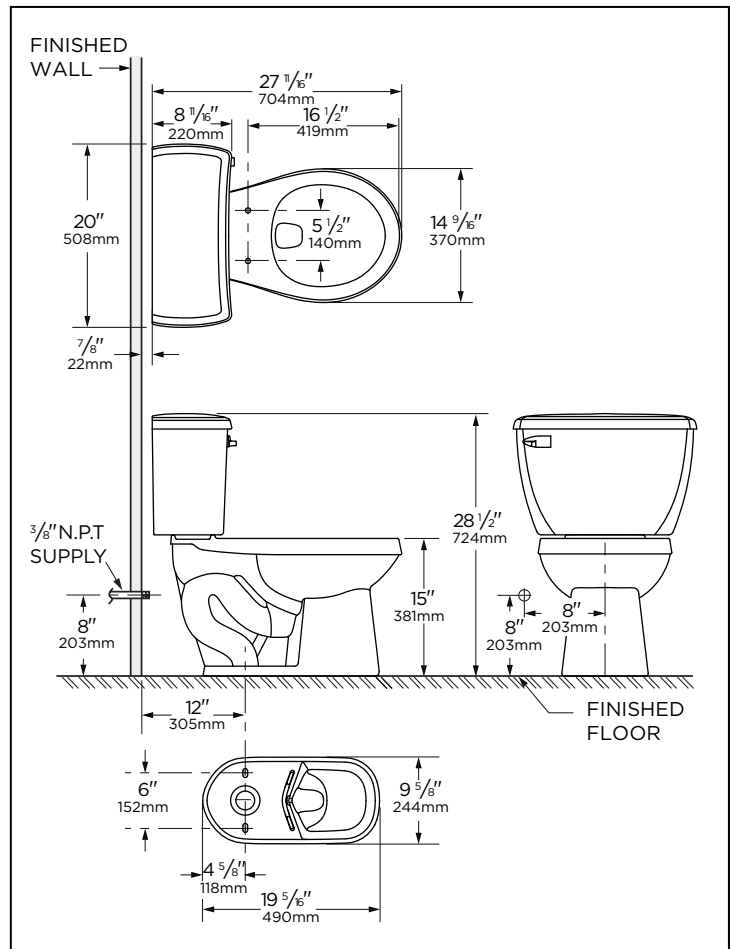

**NOTES:** All dimensions are in inches and millimeters. Illustrations may not be drawn to scale.

**IMPORTANT:**

Dimensions of fixtures are nominal and may vary within the range of tolerances established by ASME standard A 112.19.2 THIS FIXTURE QUALIFIES ACCORDING TO ASME TEST PROCEDURES AS A HIGH EFFICIENCY WATER CLOSET WITH AN AVERAGE CONSUMPTION OF 1.28 gpf (4.8 Lpf) OR LESS.