



FANTINI
RUBINETTI

2/3WAY DIVERTERS

Instructions / Instrucciones



ART. F276BU



ART. G276BU



ART. 0676BU

Tools needed / Instrumentos necesarios

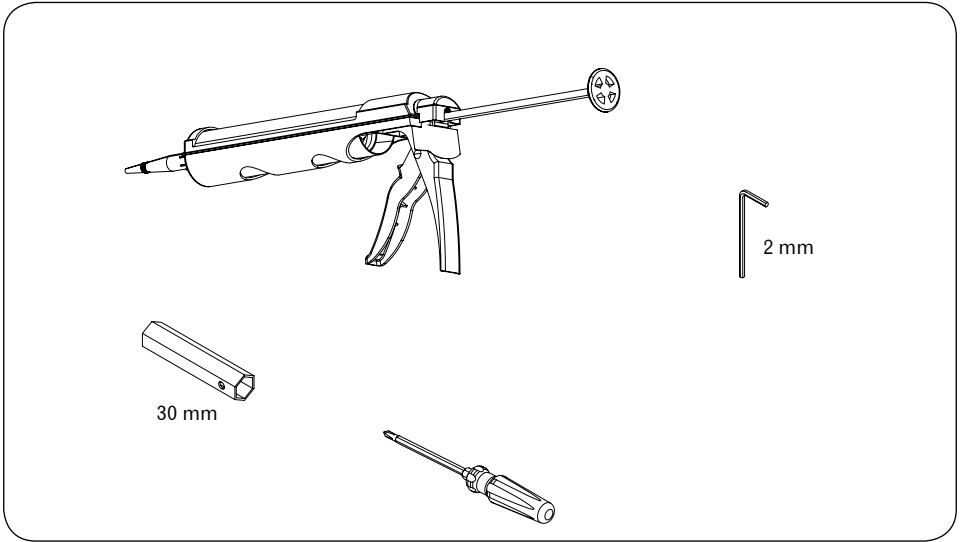

Index / Índice

F276BU External pieces / Parte externa.....	4
Adjustments / Ajustes.....	7
G276BU External pieces / Parte externa.....	8
Adjustments / Ajustes.....	11
0676BU External pieces / Parte externa.....	12
Adjustments / Ajustes.....	15
Diverter Replacement / Sustitucion del distribudor.....	16
Technical data / Datos Tècnicos.....	17

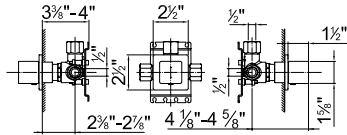

ART. D276AU+F276BU External pieces / Parte externa

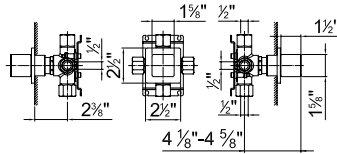

ART. D277AU+F276BU External pieces / Parte externa

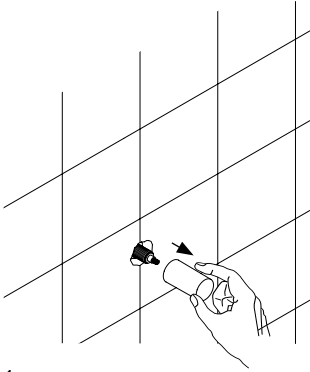

1.

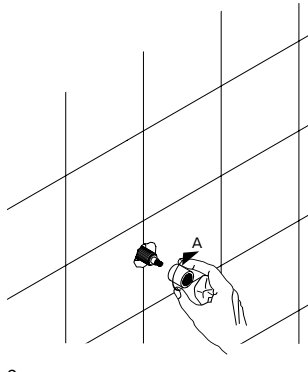

2.



- Place some silicon uniformly around the edge of the built-in body until the outer wall. Other types of insulation may be used as needed.
- Aplicar silicona uniformemente en todo el perímetro del cuerpo a empotrar hasta el revestimiento externo de la pared. También se pueden utilizar otros tipos de aislantes de acuerdo con las necesidades.

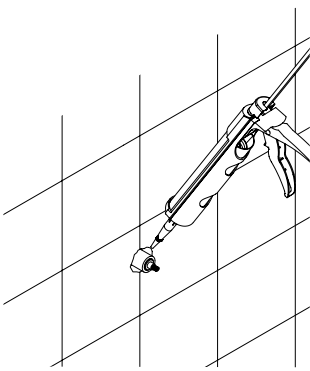

3.

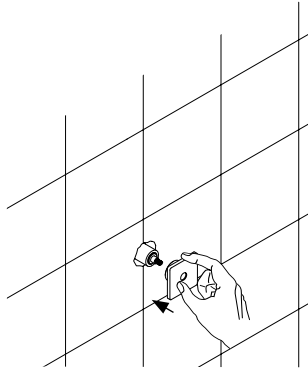

4.

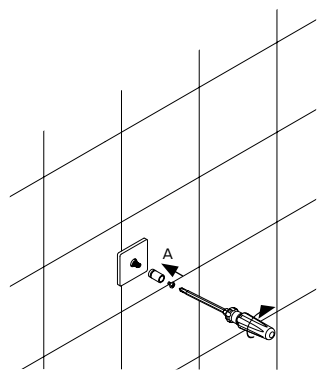

5.

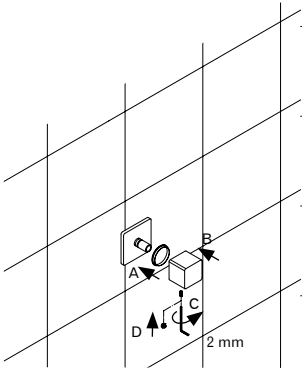

6.

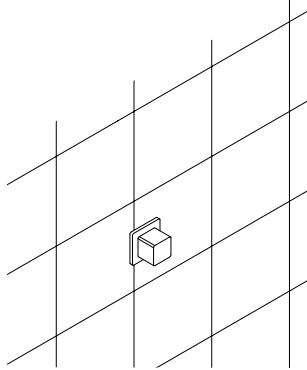

7.

Adjustments / Ajustes

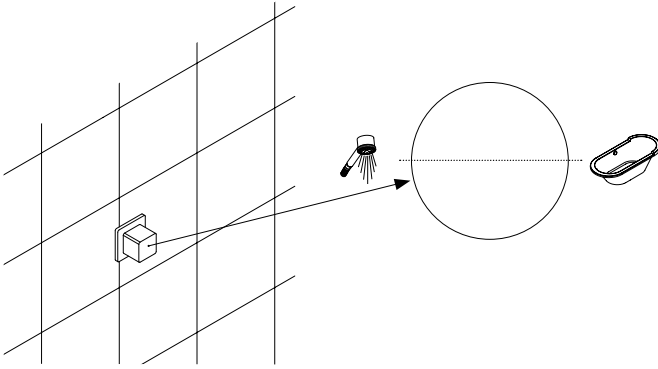

1. D276AU

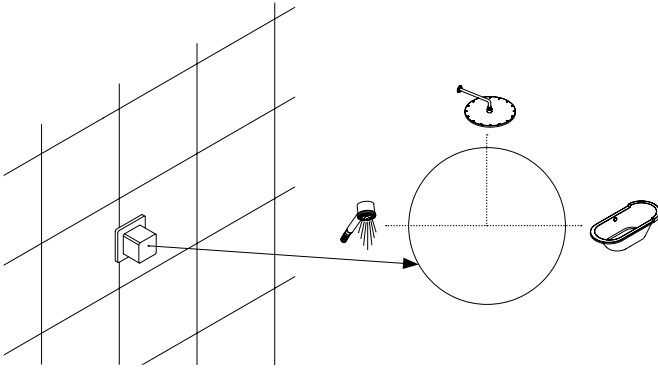

1. D277AU

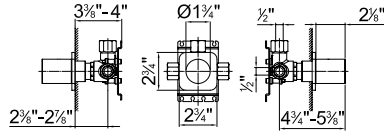

ART. D276AU+G276BU External pieces / Parte externa

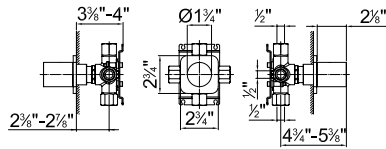

ART. D277AU+G276BU External pieces / Parte externa

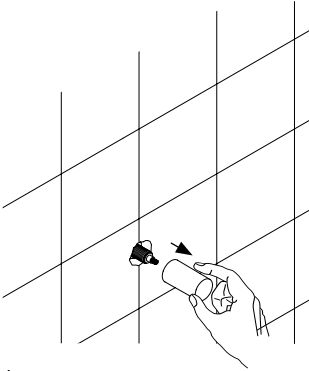

1.

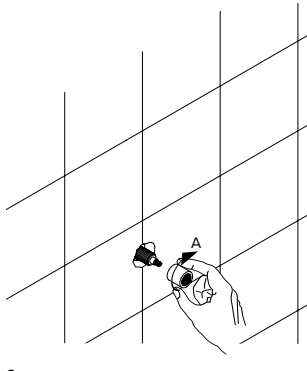

2.



- Place some silicon uniformly around the edge of the built-in body until the outer wall. Other types of insulation may be used as needed.
- Aplicar silicona uniformemente en todo el perímetro del cuerpo a empotrar hasta el revestimiento externo de la pared. También se pueden utilizar otros tipos de aislantes de acuerdo con las necesidades.

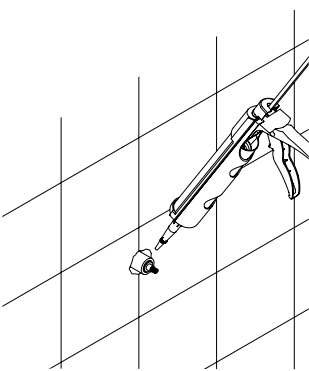

3.

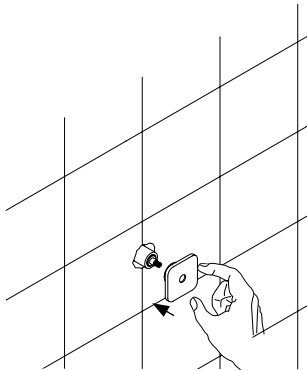

4.

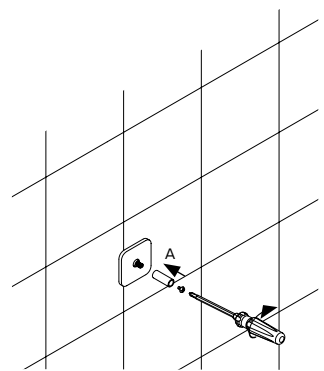

5.

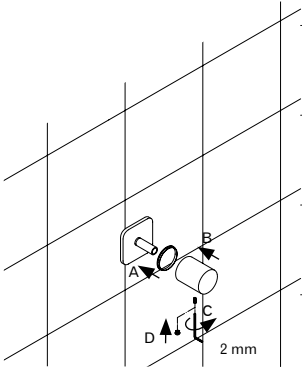

6.

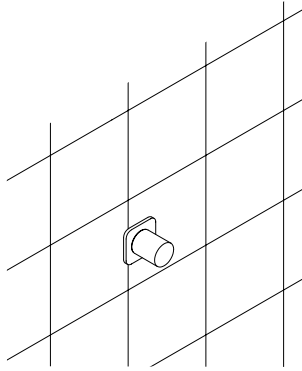

7.

Adjustments / Ajustes

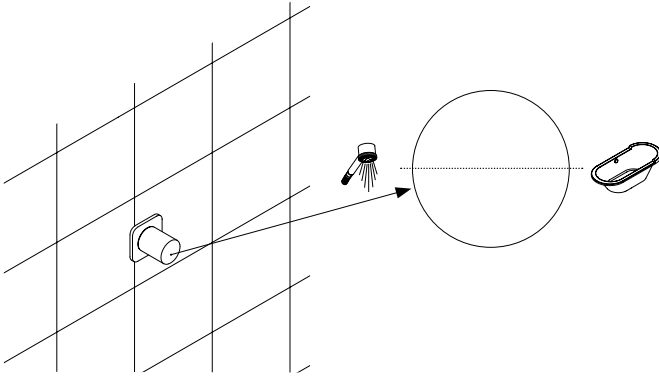

1. D276AU

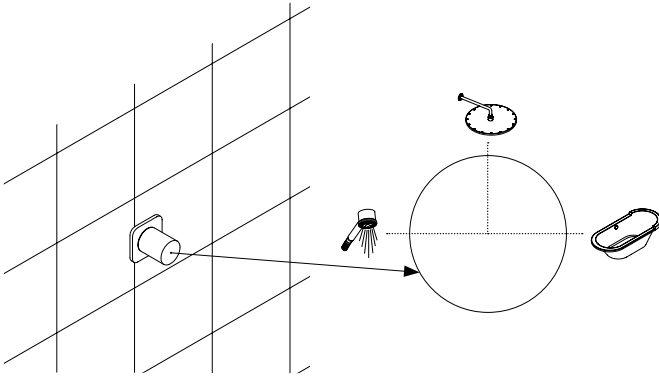

1. D277AU

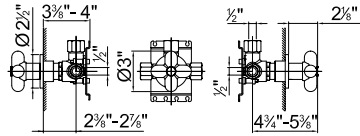

ART. D276AU+0676BU External pieces / Parte externa

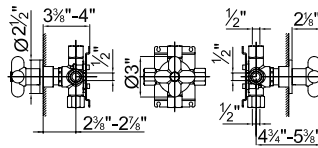

ART. D277AU+0676BU External pieces / Parte externa

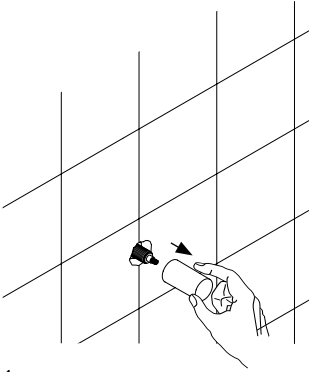

1.

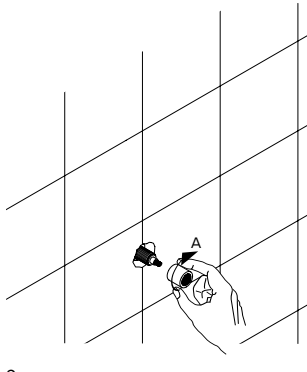

2.



- Place some silicon uniformly around the edge of the built-in body until the outer wall. Other types of insulation may be used as needed.
- Aplicar silicona uniformemente en todo el perímetro del cuerpo a empotrar hasta el revestimiento externo de la pared. También se pueden utilizar otros tipos de aislantes de acuerdo con las necesidades.

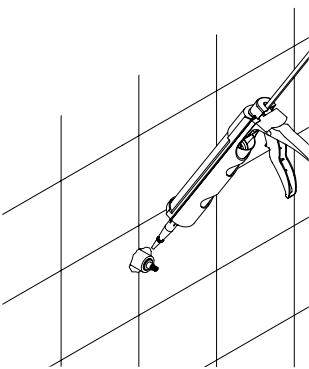

3.

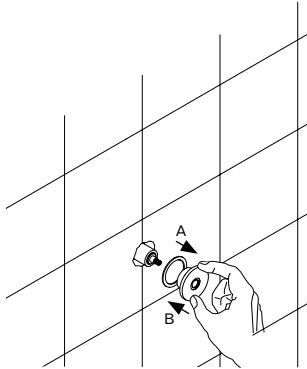

4.

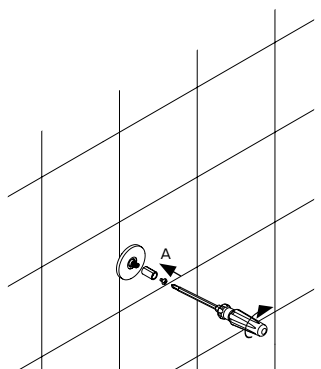

5.

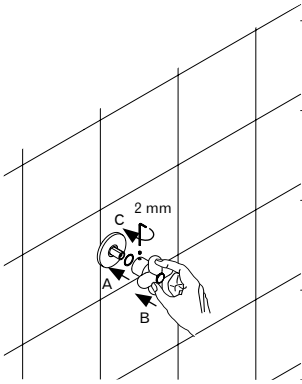

6.

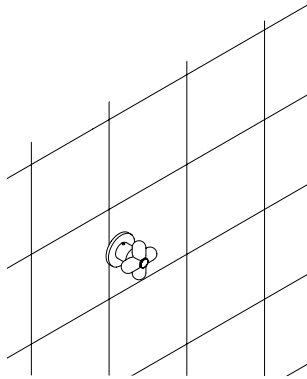

7.

Adjustments / Ajustes

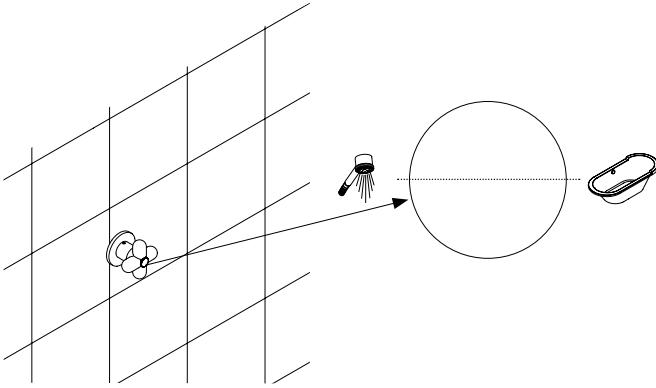

1. D276AU

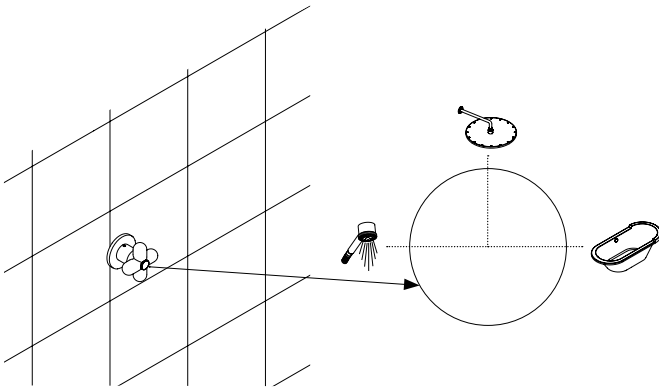

1. D277AU

Diverter replacement / Sostitución del distribuidor

For art. F276BU - G276BU - 0676BU

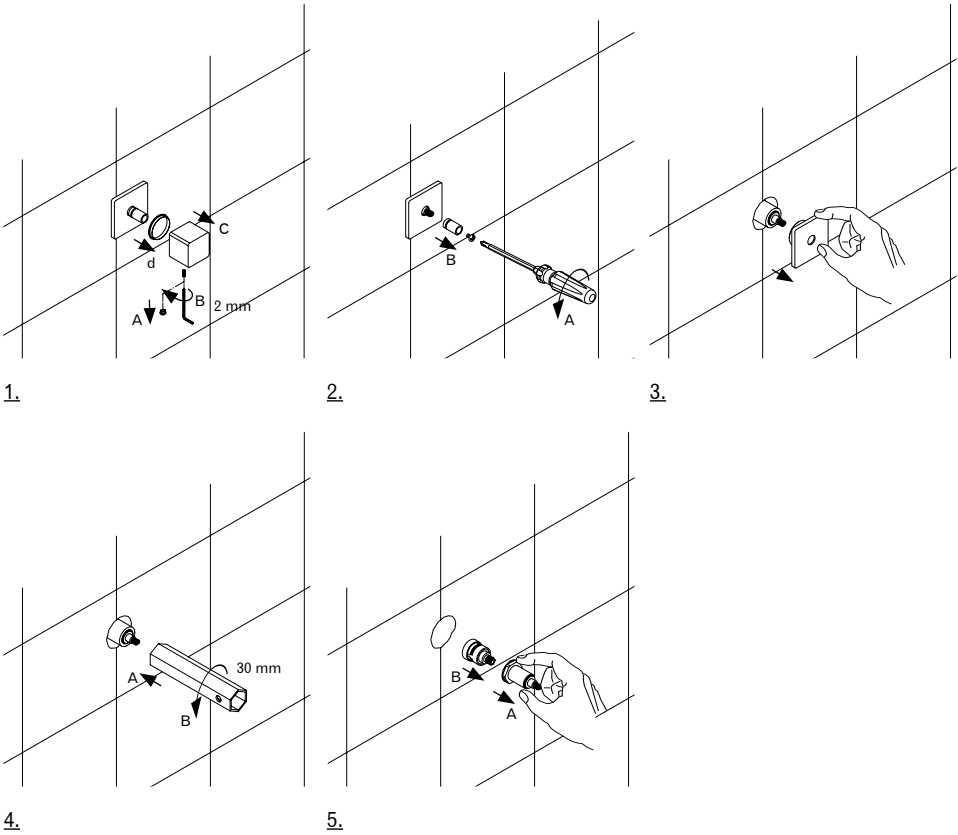

Replace following the instructions in reverse order (5-4-3-2-1).
Colocar según el procedimiento inverso (5-4-3-2-1).

Technical data

Minimum pressure.....	1 BAR
Maximum pressure.....	10 BAR
Reccomended working pressure.....	2-5 BAR
Maximum water temperature.....	80°
Maximum water temperature reccomended.....	Min. 55 Max 65°C
Maximum in-let pressure difference (hot - cold).....	1.5 BAR

Operating instructions

These mixers can be used with cumulos boilers or instantaneous water heaters.

Warning

The supplying pipes must be carefully cleaned before installation.

ENGLAND.

Datos Técnicos

Presion mínima.....	1 BAR
Presion máxima.....	10 BAR
Presion de trabajo aconsejada.....	2-5 BAR
Temperatura máxima.....	80°
Temperatura máxima aconsejada.....	Min. 55 Max 65°C
Diferencial maxima de presiún de entrada (caliente - fria).....	1.5 BAR

Aplicaciones

Estos monomandos pueden ser utilizados con acumuladores de agua caliente a presión.

Advertencias

Antes de conectar el monomando es necesario purgar correctamente la instalación hidráulica de alimentación de cualquier impureza que pueda tener.

SPAIN.

Advice on product care

To clean the surface use a soap and water solution.

Never use for any reason cleaning solutions containing abrasive substances, chloric acids, ammonia, vinegar, bleach, domestic acids, disinfectants, or anytype of abrasive pad.

WARNING! Incorrect cleaning may permanently ruin the surface of the products and in such case the manufacturer may not be held liable for damage.

The Manufacturer reserves the right to modify product and accessories at any time without prior notice. Datas, products and sketches included in this document are just for information and do not bind the producer.

ENGLAND.

Consejos para el cuidado del producto

La limpieza de las superficies se hace utilizando un jabón líquido diluido en agua.

No usar en ningún caso detergentes líquidos que contengan sustancias abrasivas ó a base de ácido clorhídrico, estropajos abrasivos, amoníaco, acetona, lejía, ácidos de uso doméstico, desinfectantes varios.

ATENCIÓN! El uso de productos desaconsejados puede danar irremediabilmente las superficies de los elementos, de lo cual el fabricante no se hará responsable en ningún caso.

La sociedad se reserva el derecho de modificar sus productos y accesorios en cualquier momento y sin previo aviso.

SPAIN.

Notes / Notas

.....

.....

.....

.....

.....

.....

.....

.....

.....

.....

.....

.....

.....

.....

.....

.....

.....

.....

.....

.....

.....

.....

.....

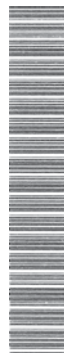

Disegni e grafica: www.dipi-designs.com

113400007000000 Rev. 0