

\*This part requires two clamps, part number 104-300. See additional drawing for information on these clamps.

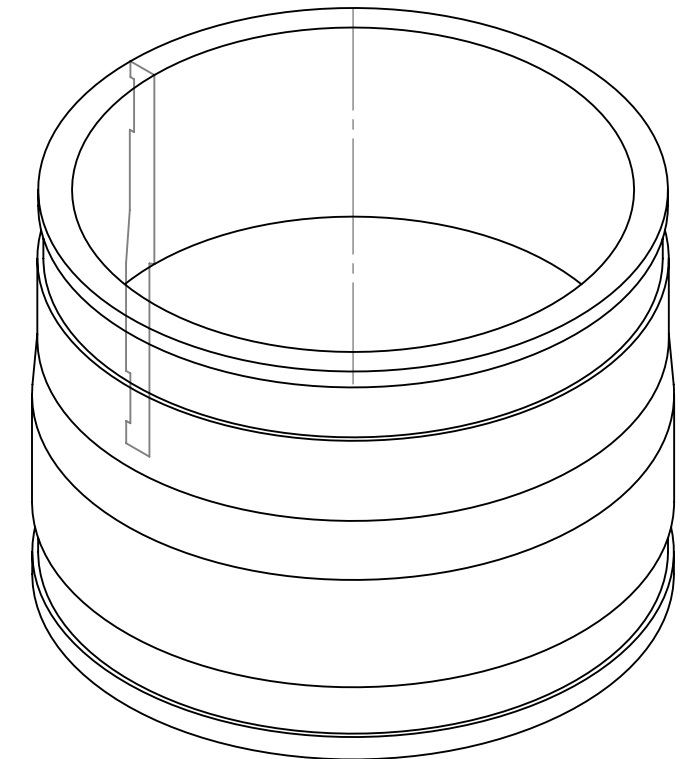

300 S. DAYTON ST.  
DAVISON, MI 48423  
PH: 810-653-9626  
FAX: 810-654-2616

Part Weight	1.80 lbs.
Min/Max Temp.	-30/140 Degrees F
Pressure Tested	4.3 PSI
Material	Flexible PVC
Installation Torque	60" Lbs.
Conforms to ASTM	D5926
Box Quantity	10
Clamps used	300 Series

TOLERANCES:  
.X= Fractional ±  
.XX= ±.02  
.XXX= ±.030  
ANG.= ±0.5°  
UNLESS OTHERWISE SPECIFIED

DESCRIPTION:  
Coupling 5" Clay x 5" A/C-D.I.  
  
1003-55

NOTES:  
- SOME HIDDEN LINES NOT SHOWN  
- BREAK ALL SHARP CORNERS  
- REPORT ALL CHANGES TO ENGINEERING

**PROPRIETARY AND CONFIDENTIAL**  
THE INFORMATION CONTAINED IN THIS DRAWING IS THE SOLE PROPERTY OF FERNCO, INC. ANY REPRODUCTION IN PART OR AS A WHOLE WITHOUT THE WRITTEN PERMISSION OF FERNCO, INC. IS PROHIBITED.

UNITS: INCHES	SIZE <b>A</b>	DESIGNER: <b>D. Brady</b>	SCALE not to scale
3RD ANGLE PROJECTION DO NOT SCALE DRAWING		CHECKER: DATE: 5/14/2007	SHEET 1 OF 1