

## FFRA0511U1

### HOME COMFORT

#### MINI AIR CONDITIONER

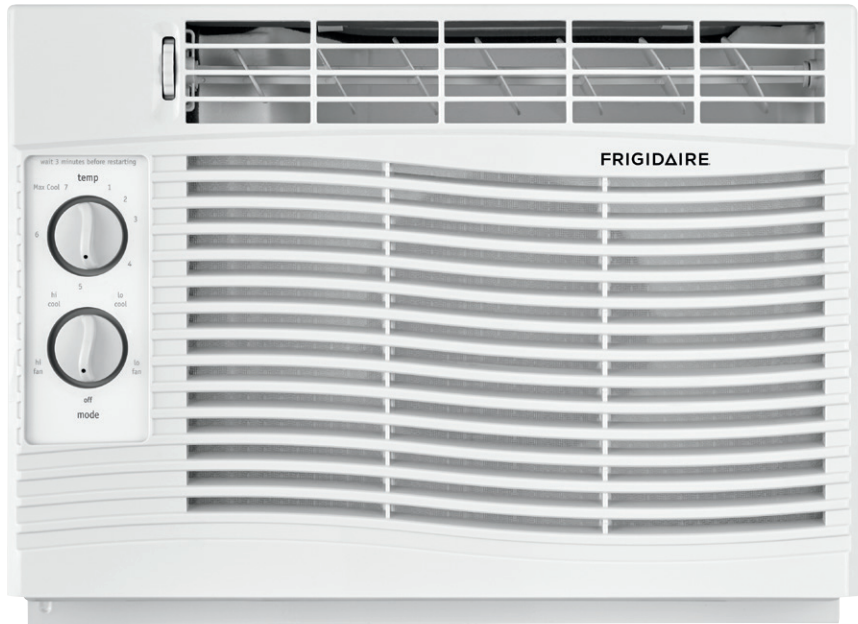

#### PRODUCT DIMENSIONS

Height	11-7/8"
Width	16-1/16"
Depth	16-7/32"

#### MORE EASY-TO-USE FEATURES

##### Effortless™ Clean Filter

Our antibacterial filter reduces bacteria, room odors and other airborne particles for a healthier, more comfortable environment.

PERFORMANCE	BTUS
Cool	5,050

### SIGNATURE FEATURES

#### SpaceWise® Adjustable Side Panels

The Adjustable Side Panels will extend to best fit your window.

#### Effortless™ Restart

Automatically resumes operating at its previous settings when power is restored to your unit.

#### Power Cord

Comes with an extra long three-prong cord — makes extension cords unnecessary.

#### Effortless™ Temperature Control

Our air conditioners maintain the preset room temperature, so you will remain comfortable at all times.

# FFRA0511U1 HOME COMFORT

## MINI AIR CONDITIONER

FRIGIDAIRE

### PERFORMANCE

BTU (Cool)	5,050
Dehumidification (Pints/Hour)	1.6
Cool Area (Up To Sq.Ft.)	150
Combined Energy Efficiency Ratio	11.0
Energy Efficiency Ratio	11.2

### ELECTRICAL

Volts	115
Amps (Cool)	4.0
Watts (Cool)	450
Length of Power Cord (Min./Max.)	6' / 6.5'
Plug Type (NEMA)	LCDI (5-15P)

### FEATURES

Electronic Controls	Mechanical
Fan Speeds (Cool/Fan)	2/2
Low Voltage Start-Up	Yes
Auto Cool Function	
Energy Saver Mode	
Sleep Mode	
Filter Check	
24-Hour On/Off Timer	
Clean Air Ionizer	
Remote Control	
Air CFM (High/Low)	147 / 124
Air Direction Control	2-Way
Fresh Air/Exhaust Vent/Closed	No/No/Yes
Filter Type	Antibacterial Mesh
Filter Access	Side Slide-Out
Slide-Out Chassis	
Window Mounting Kit (Included)	Pleated Quick Mount
Warranty <sup>1</sup>	Yes

### CERTIFICATIONS

Performance	AHAM
-------------	------

### SPECIFICATIONS

Refrigerant	R410a
Shipping Weight (Approx.)	47 Lbs.

<sup>1</sup>Warranty 5 year sealed system/1 year full parts and labor.

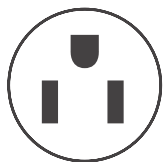

Plug Type (NEMA)  
5-15P

### PRODUCT DIMENSIONS

A - Height	11-7/8"
B - Width	16-1/16"
C - Depth	16-7/32"

### WINDOW DIMENSIONS

D - Height (Min.)	14-1/2"
E - Width (Min./Max.)	23' / 36"

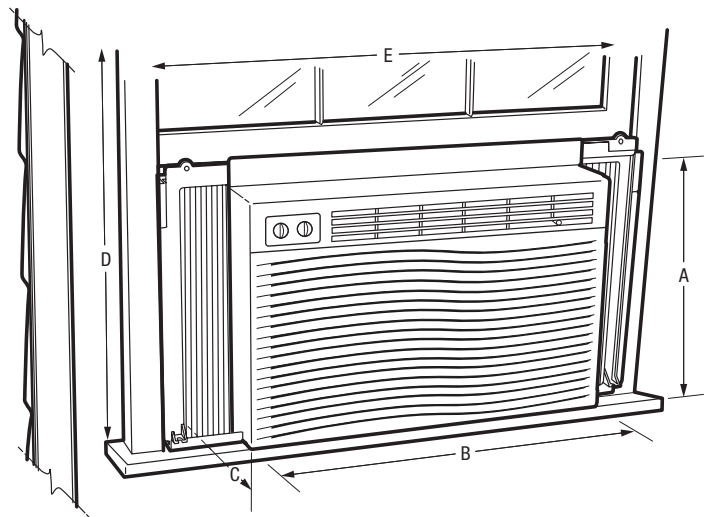

**Note:** For planning purposes only. Always consult local and national electric, gas and plumbing codes. Refer to Product Installation Guide for detailed installation instructions on the web at [frigidaire.com](http://frigidaire.com).

Specifications subject to change. Accessories information available on the web at [frigidaire.com](http://frigidaire.com)

FRIGIDAIRE

USA • 10200 David Taylor Drive • Charlotte, NC 28262 • 1-800-FRIGIDAIRE • [frigidaire.com](http://frigidaire.com)  
CANADA • 5855 Terry Fox Way • Mississauga, ON L5V 3E4 • 1-800-265-8352 • [frigidaire.ca](http://frigidaire.ca)

FFRA0511U1 01/18  
© 2018 Electrolux Home Products, Inc.