

Dual Fuel Range, 30", 4 Burners, Self-cleaning, LPG

Series 9 | Professional

Stainless Steel | LPG



Get the best of gas and convection technology in this striking range with intuitive touchscreen and specialized cooking functions.

- Guided cooking using your touchscreen makes it simple to cook by food, function or recipe.
- Top burner heat of 19,000 BTU, for seriously fast boiling
- 4 cu ft total oven capacity
- Beautiful LED halo-illuminated dials provide information at a glance

DIMENSIONS

Height	35 ³ / ₄ - 36 ³ / ₄ "
Width	29 ⁷ / ₈ "
Depth	29 ¹ / ₈ "

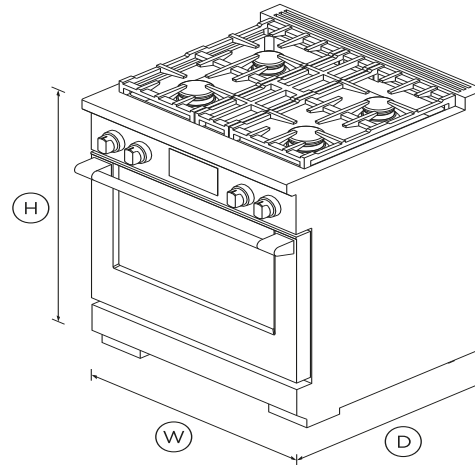

FEATURES & BENEFITS

Cook with confidence

Our touchscreen interface provides an intuitive guided cooking experience that helps deliver perfect results, whether you've been cooking all your life or just starting out. Cook with a favorite method, a hero ingredient, or a go-to cooking function or recipe. The screen tilts for improved ergonomics and optimal visibility while cooking.

Generous capacity

Featuring a generous total capacity of 4 cu ft, with enough room

to fit a 26 lb turkey, or to cook several dishes at once.

Cooking flexibility

No matter what you're cooking, you've got the right heat to get perfect results. Each of the 15 oven functions have been extensively researched and carefully designed to cater to a broad range of dishes and cooking styles. The handy food probe helps you monitor your progress.

Cooktop power

Sealed dual flow burners deliver cooktop power up to 19,000 BTU for seriously fast boiling, and precise 140°F full surface, low temperature cooking with the gentlest of flames.

Design quality

This range has craftsmanship in every detail, with real stainless steel, cast-iron trivets, and beautifully weighted, halo illuminated dials. Each cavity features incandescent lights and full extension telescopic racks. From the robust legs to the powerful cooktop, this Range is built to last.

Easy to clean

The oven features a self-cleaning function and self-clean proof side racks, which don't need to be removed when using this function.

SPECIFICATIONS

Accessories

Adjustable feet covers	•
Branded coin end cap	•
Square handle option	AH-R30

Capacity

Shelf positions	5
Total capacity	4 cu ft
Usable capacity	3.3 cu ft

Cleaning

- Easy clean porcelain basepan
- Pyrolytic self-clean

Controls

- Dial with illuminated halo
- High resolution display
- Metal illuminated dials
- Multi-language interface
- Sabbath mode
- Titanium coated, illuminated
- Wifi connectivity

Gas requirements

- Fitting and pipe **½ NPT, min. 5/8" Ø flex line**
- Supply Pressure (LPG) **11" to 14" W.C**

Main oven functions

- Convection broil

Oven features

- Broil pan
- Concealed element
- Electronic oven control
- Food probe
- Full extension telescopic **2**
- Internal light
- Self-cleaning
- True convection

Oven functions

- Air fry
- Bake
- Classic bake
- Clean
- Convection Broil
- Convection bake
- Dehydrate
- Maxi Broil
- Number of functions **15**
- Pastry Bake
- Pizza bake
- Rapid proof
- Roast
- Slow cook
- True convection
- Warm

Oven performance

- Bake power **3500W**
- Broil power **4000W**
- Main oven - True convection **2500W**

Power requirements

- Amperage **30A**
- Supply frequency **60Hz**
- Supply voltage **120 - 240V**

Product dimensions

- Depth **29 1/8"**
- Height **35 3/4" - 36 3/4"**
- Width **29 7/8"**

Rangetop features

- Sealed Dual Flow Burners™ **4**
- Simmer on all burners **140°F**
- Vent trim included **Flat vent trim**

Rangetop Performance

- Max burner power **19000 BTU**
- Power back left **13000 BTU**
- Power back right **13000 BTU**
- Power front left **19000 BTU**
- Power front right **15000 BTU**
- Total cooktop power **60000 BTU**

Recommended back guards and ventilation

- Combustible situation **BGRV3-3030H**
- Non combustible situation **BGRV2-3030 / BGRV2-1230**
- Recommended hood **HCB30-6_N (Professional)**

Safety

- ADA compliant
- Full extension telescopic

Warranty

- Parts and labor **Limited 2 years**

SKU

81901

TEST The product dimensions and specifications in this page apply to the specific product and model. Under our policy of continuous improvement, these dimensions and specifications may change at any time. You should therefore check with Fisher & Paykel's Customer Care Centre to ensure this page correctly describes the model currently available. ? Fisher & Paykel Appliances Ltd 2020

Other product downloads available at fisherpaykel.com



User Guide



Service & Warranty Booklet



Installation Guide



Resources (zip)



A PEACE OF MIND SALE

24 Hours 7 Days a Week Customer Support

T 1.888.936.7872 W www.fisherpaykel.com