

Dual Fuel Range, 36", 6 Burners, Self-cleaning

Series 9 | Professional

Stainless Steel | Natural gas



Get the best of gas and convection technology in this striking range with intuitive touchscreen and specialized cooking functions.

- Guided cooking using your touchscreen makes it simple to cook by food, function or recipe.
- Top burner heat of 23,500 BTU, for seriously fast boiling
- 4.8 cu ft total oven capacity
- Beautiful LED halo-illuminated dials provide information at a glance

DIMENSIONS

Height	35 ³ / ₄ - 36 ³ / ₄ "
Width	35 ⁷ / ₈ "
Depth	29 ¹ / ₈ "

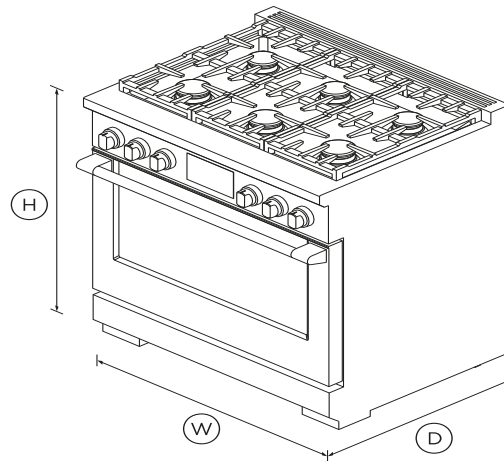

FEATURES & BENEFITS

Cook with confidence

Our touchscreen interface provides an intuitive guided cooking experience that helps deliver perfect results, whether you've been cooking all your life or just starting out. Cook with a favorite method, a hero ingredient, or a go-to cooking function or recipe. The screen tilts for improved ergonomics and optimal visibility while cooking.

Generous capacity

Featuring a large 4.8 cu ft total capacity convection oven, with

enough room to fit a 32 lb turkey and full-size baking sheets.

Cooking flexibility

No matter what you're cooking, you've got the right heat to get perfect results. Each of the 15 oven functions have been extensively researched and carefully designed to cater to a broad range of dishes and cooking styles. The handy food probe helps you monitor your progress.

Cooktop power

Sealed dual flow burners deliver cooktop power up to 23,500 BTU for seriously fast boiling, and precise 140°F full surface, low temperature cooking with the gentlest of flames.

Design quality

This range has craftsmanship in every detail, with real stainless steel, cast-iron trivets, and beautifully weighted, halo illuminated dials. Each cavity features incandescent lights and full extension telescopic racks. From the robust legs to the powerful cooktop, this Range is built to last.

Easy to clean

The oven features a self-cleaning function and self-clean proof side racks, which don't need to be removed when using this function.

SPECIFICATIONS

Accessories

Square handle option	AH-R36
----------------------	--------

Capacity

Shelf positions	5
Total capacity	4.8 cu ft
Usable capacity	3.8 cu ft

Cleaning

Pyrolytic self-clean •

Controls

- Dial with illuminated halo •
- High resolution touch display •
- Multi-language interface •
- Precise cooking with food •
- Recipe and food based •
- Sabbath mode •
- Tilting touch screen interface •
- Titanium coated, illuminated •
- Wifi connectivity •

Gas requirements

Fitting and pipe ½ NPT, min. ⅝" Ø flex line
 Supply Pressure (natural gas) 6" to 9" W.C

Oven features

- Concealed element •
- Electronic oven control •
- Food probe •
- Full extension telescopic 2
- Internal light •
- Large broil pan •
- Self-clean proof side racks •
- Self-cleaning •
- True convection •

Oven functions

- Air fry •

- Bake •
- Classic bake •
- Clean •
- Convection Broil •
- Convection bake •
- Dehydrate •
- Maxi Broil •
- Number of functions 15
- Pastry Bake •
- Pizza bake •
- Rapid proof •
- Roast •
- Slow cook •
- True convection •
- Warm •

Oven performance

Bake power 4600W
 Broil power 4000W
 Main oven - True convection 2500W

Power requirements

Amperage 30A
 Supply frequency 60Hz
 Supply voltage 120 - 240V

Product dimensions

Depth 29 1/8 "
 Height 35 3/4 - 36 3/4 "
 Width 35 7/8 "

Rangetop features

Sealed Dual Flow Burners™ 6
 Simmer on all burners 140°F
 Vent trim included Flat vent trim

Rangetop Performance

Max burner power 23,500 BTU
 Power back centre 18,500 BTU
 Power back left 18,500 BTU
 Power back right 18,500 BTU
 Power front centre 18,500 BTU
 Power front left 23,500 BTU
 Power front right 23,500 BTU
 Total cooktop power 121,000 BTU

Recommended back guards and ventilation

Combustible situation BGRV3-3036H
 Non combustibile situation BGRV2-3036 / BGRV2-1236
 Recommended hood HCB36-6_N (36" Professional)

Safety

- ADA compliant •
- Full extension telescopic •

Warranty

Parts and labor Limited 2 years

SKU 81898

TEST The product dimensions and specifications in this page apply to the specific product and model. Under our policy of continuous improvement, these dimensions and specifications may change at any time. You should therefore check with Fisher & Paykel's Customer Care Centre to ensure this page correctly describes the model currently available. ? Fisher & Paykel Appliances Ltd 2020

Other product downloads available at fisherpaykel.com



User Guide



Service & Warranty Booklet



Installation Guide



Resources (zip)



A PEACE OF MIND SALE

24 Hours 7 Days a Week Customer Support

T 1.888.936.7872 W www.fisherpaykel.com