

Oven, 24", 7 Function, Self-cleaning

Series 5 | Contemporary

Stainless Steel



With generous capacity and beautiful contemporary styling, this built-in oven will complement your kitchen design perfectly.

- Three cubic feet total capacity, with seven oven functions including Aero™ Pastry
- Self-cleaning function breaks down food residue for an easy clean
- Moisture control and even heat distribution thanks to ActiveVent™ and AeroTech technology
- Optional non-tip, full-extension sliding shelves for safe removal of hot dishes

DIMENSIONS

Height	23 ⁹ / ₁₆ "
Width	23 ¹ / ₂ "
Depth	22 ¹ / ₄ "

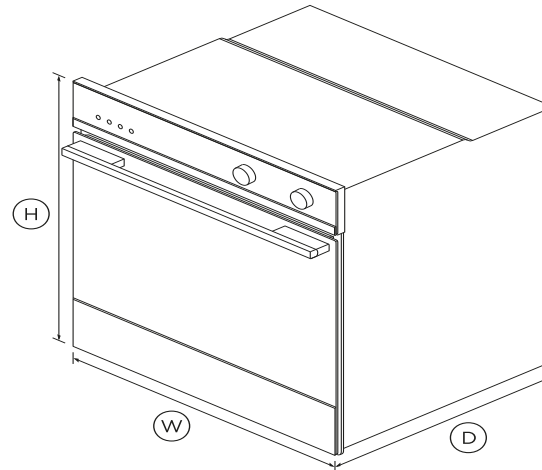

FEATURES & BENEFITS

Generous capacity

With a generous sized internal cavity, you can create several dishes at once using multiple shelves.

Perfect Results

Our built-in ovens feature ActiveVent technology for optimized moisture levels, and AeroTech™ for even heat distribution. Get perfect results even when you're using multiple shelves.

Multi-function flexibility

Seven functions including Aero™ Pastry, Aero™ Bake and True Aero™ mean no matter what you're cooking, you've got the right heat to match.

Seamless fit

Designed to fit seamlessly in your kitchen, this built-in oven fits flush with cabinetry to minimize gaps and add to a cohesive aesthetic.

Cleaning is simple

<>

Refined styling

With sophisticated handle styling and stainless steel finish, our built-in ovens are designed to match the rest of Fisher & Paykel's kitchen appliance family.

Safe and sound

The CoolTouch door features triple glazing and a cooling system that ensures it's safe to touch from the outside – protecting both your hands and the surrounding cabinetry.

SPECIFICATIONS

Accessories

Flat wire shelf	•
Food probe	•
Meat probe	•
Pyrolytic proof shelf runners	1 set
Step down wire shelf	•

Capacity

Shelf positions	6
Total capacity	3 cu ft
Usable capacity	2.5 cu ft

Cleaning	
Acid resistant graphite enamel	•
Pyrolytic proof shelf runners	•
Removable oven door	•
Removable oven door inner	•
Removable shelf runners	•
Self-clean	•
Controls	
Audio feedback	•
Automatic cooking/minute	•
Automatic pre-set	•
Behind glass capacitive touch	•
Celsius/Fahrenheit	•
Electronic capacitive touch	•
Electronic clock	•
Electronic oven control	•
Interior light	2 x 25W (halogen)
Precise electronic temperature	•
Sabbath mode	•
Functions	
Aero Bake	•
Aero Broil	•
Bake	•
Broil	•
Maxi Broil	•
Number of functions	7
Rapid proof	•

Roast	•
Self-clean function	•
True Aero	•
Vent bake	•
Performance	
ActiveVent™ system	•
AeroTech™ technology	•
Automatic rapid pre-heat	•
Broil power	3200W
Whisper quiet cooking	•
Power requirements	
Amperage	19A
Supply frequency	60Hz
Supply voltage	208 - 240V
Product dimensions	
Depth	22 1/4 "
Height	23 9/16 "
Width	23 1/2 "
Safety	
Advanced cooling system	•
Balanced oven door	•
Catalytic venting system	•
Control panel key lock	•
Non-tip shelves	•
Warranty	

Parts and labor	2 years
SKU	81887

TEST The product dimensions and specifications in this page apply to the specific product and model. Under our policy of continuous improvement, these dimensions and specifications may change at any time. You should therefore check with Fisher & Paykel's Customer Care Centre to ensure this page correctly describes the model currently available. ? Fisher & Paykel Appliances Ltd 2020

Other product downloads available at fisherpaykel.com



User Guide



Service & Warranty Booklet



Installation Guide



Resources (zip)



A PEACE OF MIND SALE

24 Hours 7 Days a Week Customer Support

T 1.888.936.7872 **W**www.fisherpaykel.com