

Gas Range, 30", 5 Burners, LPG

Series 7 | Professional

Stainless Steel | LPG



Professional style and performance, with powerful burners delivering high heat or the most gentle simmer.

- Top burner heat of 19,000 BTU, for seriously fast boiling
- Gas oven with 4.6 cu ft total capacity
- Non-tip full-extension shelves for safe removal of hot dishes

DIMENSIONS

Height	35 ³ / ₄ - 36 ³ / ₄ "
Width	29 ⁷ / ₈ "
Depth	29 ¹ / ₈ "

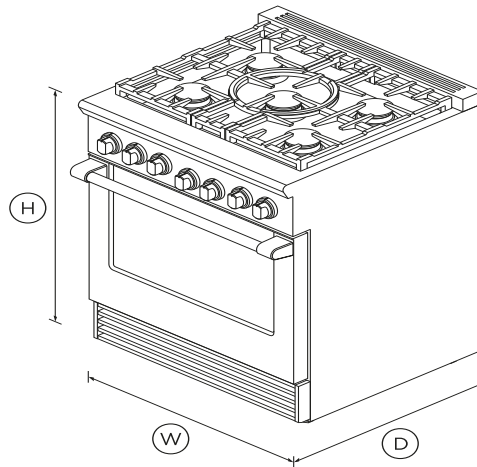

FEATURES & BENEFITS

Cooktop power

Sealed Dual Flow Burners™ deliver cooktop power up to 23,500 BTU (NG models) for seriously fast boiling right down to a precise 140°F full surface simmer with the gentlest of flames.

Total control

Precise control across high and low settings is delivered through the halo-illuminated cooktop dials. The ovens have true convection and electronic oven control for precise and consistent temperatures.

Easy to clean

A sealed cooktop surface coupled with a commercial-style stainless steel finish means your cooktop simply needs a quick wipe to keep it looking good as new.

Instant visibility

Control dials have halo-illumination glowing white – heating up; orange – temperature reached; red – self-cleaning mode. The oven is illuminated by two powerful incandescent lights.

Cooking flexibility

The cooktop is designed for easy access to any burner with grates you can smoothly slide pots across. The oven is large enough to hold full size baking sheets.

<<Missing Feature Title>>

This range has been carefully crafted in every detail from performance to durability using quality materials.

SPECIFICATIONS

Accessories

Square handle option	AH-R30
----------------------	--------

Controls

Metal illuminated dials	•
-------------------------	---

Gas requirements

Fitting and pipe	½ NPT, min. ⅝" Ø flex line
------------------	----------------------------

Main oven features

Broil pan	•
Capacity total (AHAM)	4.6cu ft
Capacity usable (AHAM)	3.4cu ft
Electronic oven control	•

Infrared Broiler	•
Internal Light	•
Shelf positions	5

Main oven functions

Bake	28000BTU
Broil	19000BTU
Number of main oven	3

Oven features

Full extension telescopic	3
---------------------------	---

Power requirements

Supply frequency	60
Supply voltage	120

Product dimensions

Depth	29 1/8"
Height	35 3/4" - 36 3/4"
Width	29 7/8"

Rangetop features

Sealed Dual Flow Burners™	5
Sealed range top	•
Simmer on all burners	140°F
Vent trim included	Flat vent trim

Rangetop Performance

Max burner power	23500BTU
Power back left	18500BTU

Power back right	18500BTU
Power centre	23500BTU
Power front left	18500BTU
Power front right	18500BTU
Total cooktop power	97500BTU

Safety

Full extension telescopic	•
---------------------------	---

SKU	71359
-----	-------

TEST The product dimensions and specifications in this page apply to the specific product and model. Under our policy of continuous improvement, these dimensions and specifications may change at any time. You should therefore check with Fisher & Paykel's Customer Care Centre to ensure this page correctly describes the model currently available. © Fisher & Paykel Appliances Ltd 2020

Other product downloads available at fisherpaykel.com

- [↓](#) User Guide
- [↓](#) Service & Warranty Booklet
- [↓](#) Installation Guide
- [↓](#) Resources (zip)



A PEACE OF MIND SALE

24 Hours 7 Days a Week Customer Support

T 1.888.936.7872 W www.fisherpaykel.com