

Gas Range, 30", 4 Burners, LPG

Series 7 | Professional

Stainless Steel | LPG



Professional style and performance, with powerful burners delivering high heat or the most gentle simmer.

- Top burner heat of 19,000 BTU, for seriously fast boiling
- Convection oven with 4.6 cu ft total capacity
- Non-tip full-extension shelves for safe removal of hot dishes

DIMENSIONS

Height	35 ³ / ₄ - 36 ³ / ₄ "
Width	29 ⁷ / ₈ "
Depth	29 ¹ / ₈ "

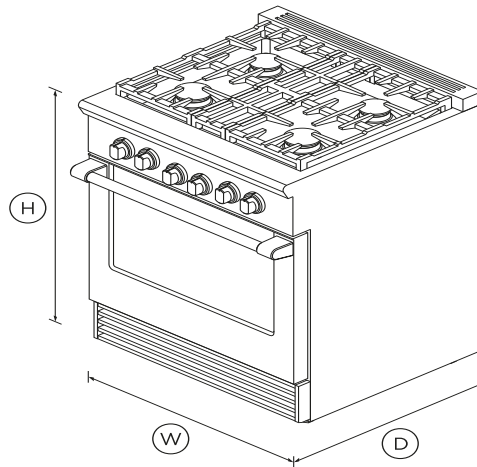

FEATURES & BENEFITS

Cooktop power

Sealed Dual Flow Burners™ deliver cooktop power up to 22,500 BTU (NG models) for seriously fast boiling right down to a precise 140°F full surface simmer with the gentlest of flames.

Total control

Precise control across high and low settings is delivered through the halo-illuminated cooktop dials. The ovens have true convection and electronic oven control for precise and consistent temperatures.

Easy to clean

A sealed cooktop surface coupled with a commercial-style stainless steel finish means your cooktop simply needs a quick wipe to keep it looking good as new.

Instant visibility

Control dials have halo-illumination glowing white – heating up; orange – temperature reached; red – self-cleaning mode. The oven is illuminated by two powerful incandescent lights.

Cooking flexibility

The cooktop is designed for easy access to any burner with grates you can smoothly slide pots across. The oven is large enough to hold full size baking sheets.

<<Missing Feature Title>>

This range has been carefully crafted in every detail from performance to durability using quality materials.

SPECIFICATIONS

Accessories

Square handle option	AH-R30
----------------------	--------

Capacity

Shelf positions	5
Total capacity	4.6 cu ft
Usable capacity	3.4 cu ft

Controls

Metal illuminated dials	•
-------------------------	---

Gas requirements

Fitting and pipe	½ NPT, min. ¾" Ø flex line
Supply Pressure (LPG)	11" to 14" W.C

Oven features

Broil pan	•
Electronic oven control	•
Full extension telescopic	3
Infrared Broiler	•
Internal light	•

Oven functions

Bake	•
Broil	•
Convection bake	•
Number of functions	3

Oven performance

Bake power	22,000 BTU
Broil power	19,000 BTU

Power requirements

Amperage	15A
Supply frequency	60Hz
Supply voltage	120V

Product dimensions

Depth	29 1/8"
Height	35 3/4" - 36 3/4"
Width	29 7/8"

Rangetop features

Dishwasher safe trivets	•
-------------------------	---

Sealed Dual Flow Burners™	4
Sealed range top	•
Simmer on all burners	140°F
Vent trim included	Flat vent trim

Rangetop Performance

Max burner power	19,000 BTU
Power back left	15,000 BTU
Power back right	15,000 BTU
Power front left	19,000 BTU
Power front right	15,000 BTU
Total cooktop power	60,000 BTU

Recommended back guards and ventilation

Combustible situation	BGRV2-3030H
Minimum CFM	600
Non combustible situation	BGRV2-3030 / BGRV2-1230
Recommended hood	HCB30-6_N (Professional)

Safety

Full extension telescopic	•
---------------------------	---

Warranty

Parts and labor	Limited 2 years
-----------------	-----------------

SKU	71357
-----	-------

and specifications may change at any time. You should therefore check with Fisher & Paykel's Customer Care Centre to ensure this page correctly describes the model currently available. © Fisher & Paykel Appliances Ltd 2020

TEST The product dimensions and specifications in this page apply to the specific product and model. Under our policy of continuous improvement, these dimensions

Other product downloads available at fisherpaykel.com



User Guide



Service & Warranty Booklet



Installation Guide



Resources (zip)



A PEACE OF MIND SALE

24 Hours 7 Days a Week Customer Support

T 1.888.936.7872 **W**www.fisherpaykel.com