



# EVERPURE® EF-1500

## EF-1500 FULL FLOW DRINKING WATER SYSTEM

The same commercial quality that makes Pentair® Everpure® the overwhelming choice for water filtration in restaurants is also available for your home—now without the need for extra faucets. The Pentair® Everpure® EF-1500 introduces great-tasting, crisp, clean filtered water at every regular tap in your home. The smaller canister size makes it an ideal system for any application where space is limited.

1500  
gallons  
**CAPACITY**  
5,600 Litres

### FEATURES

#### Easy installation

- No additional faucet required
- Built-in water shut-off allows for easier cartridge changes

#### Great Tasting Water

- Reduces particles as small as 0.5 micron in size by mechanical means
- Retains vital minerals found naturally in water to ensure the health and delicious taste of your water



#### Commercial Grade Filtration

- Helps prevent lime and scale build-up in water-using appliances
- Commercial grade metal canister protects the filter system from splitting or bursting

#### Everpure Everywhere

- Ideal for anywhere in your home, especially your bathroom sink



### SPECIFICATIONS

- **Flow rate**  
controlled at 2.2 gpm (8.3 Lpm)
- **Temperature**  
35-100° F (2-38° C)  
cold water use only
- **Pressure**  
10-125 psi (0.7-8.6 bar)  
non-shock
- **Capacity**  
1,500 gal. (5,600 L)
- **Required Space**  
5W x15H x 5D in  
13W x 38H x 13D cm

### SUBSTANCE REDUCTION

- Lead
- Chlorine taste & odor
- Dirt and cloudiness\*
- NSF/ANSI Standard 53 certified to reduce cysts such as Cryptosporidium and Giardia by mechanical means

\*As tested by Everpure, LLC.

EPA EST. NO. 002623-IL-002

## ORDERING INFORMATION

MODEL	PART NO	DESCRIPTION
EF-1500	EV985800	Drinking water system
EF-1500	EV985850	Cartridge



## GENERAL INSTALLATION / OPERATION / MAINTENANCE REQUIREMENTS

- This drinking water system must be maintained according to the manufacturer's instructions, including replacement of filter cartridges. The substances reduced or removed by this system are not necessarily in your water. Read the performance data sheet for more information.
- It is recommended that before purchasing a water treatment unit, you have your water tested to determine your actual treatment needs.
- Space required: 13W x 38H x 13D cm (5W x 15H x 5D in) including 2-1/2 inches of clear space under unit for cartridge change
- Do not use with water that is microbiologically unsafe or of unknown quality without adequate disinfection before or after the system. Systems certified for substance reduction may be used on disinfected water that may contain filterable cysts.
- Install vertically with cartridge hanging down
- Flush new cartridge at full flow for three minutes to purge air
- Replace cartridge when capacity is reached, or when flow becomes too slow, but at least annually

### Easy installation steps

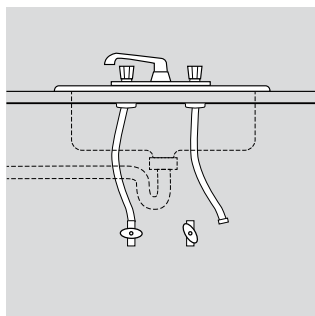

Shut cold water supply off and disconnect cold water hose.

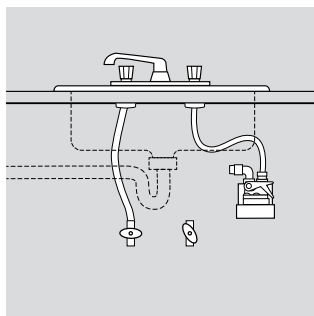

Connect cold water supply hose from faucet to outlet of filter head.

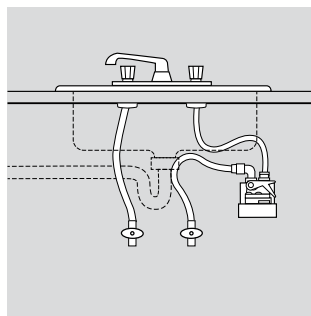

Mount filter head and connect water supply to inlet of filter head.

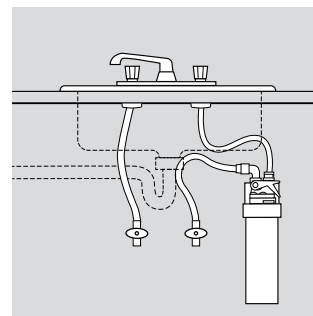

Install Quick Change cartridge and turn on water.

For detailed instructions, see the Owner's Guide.

### Health Claim Performance Certified by NSF/ANSI\*

This system has been tested according to NSF/ANSI 42 and 53 for the reduction of the substances listed below. The concentration of the indicated substances in water entering the system was reduced to a concentration less than or equal to the permissible limit for water leaving the system, as specified in NSF/ANSI 42 and 53.

SUBSTANCE	INFLUENT CHALLENGE CONCENTRATION	MAX. PERMISSIBLE PRODUCT WATER CONCENTRATION	REDUCTION REQUIREMENTS	MINIMUM REDUCTION	AVERAGE REDUCTION
<b>Standard 42 – Aesthetic Effects</b>					
Chlorine	2.0 mg ± 10%	–	≥ 50%	–	98%
Particulate, Class I					
Particles 0.5 - <1 µm	at least 10,000 particles/mL	–	≥ 85%		99.8%
<b>Standard 53 – Health Effects</b>					
Cyst	Minimum 50,000/L	–	99.95%	99.99%	99.99%
Lead 8.5	0.15 mg/L ± 10%	0.010 mg/L	–	98.9%	98.9%
Lead 6.5	0.15 mg/L ± 10%	0.010 mg/L	–	94.1%	97.2%

\*Tested using flow rate = 2.2 gpm; pressure = 60 psig; pH = 7.5 ± 0.5; temp. = 20° C ± 2.5° C

Everpure®, Micro-Pure® and the silver canister color are registered trademarks of Pentair Filtration Solutions, LLC ©2013.



System Tested and Certified by NSF International against NSF/ANSI Standard 42 and 53 for the reduction of:

#### Standard No. 42 Aesthetic Effect:

- Chemical Reduction
  - Taste and Odor
  - Chlorine Taste & Odor
- Mechanical Filtration
  - Particulate Reduction: Class I

#### Standard No. 53 Health Effects:

- Chemical Reduction
  - Lead
- Mechanical Filtration
  - Cyst

### Warranty

Everpure Drinking Water Systems are warranted to be free of defects for a full twelve (12) months after purchase. A detailed warranty statement is provided with each system.



### FILTRATION & PROCESS

5730 NORTH GLEN PARK ROAD, MILWAUKEE, WI 53209

P: 262.238.4400 | F: 262.238.4404 | WWW.PENTAIRAQUA.COM | WWW.RESIDENTIAL.EVERPURE.COM | CUSTOMER CARE: 800.279.9404

All Pentair trademarks and logos are owned by Pentair, Inc. or its affiliates. All other registered and unregistered trademarks and logos are the property of their respective owners. Because we are continuously improving our products and services, Pentair reserves the right to change specifications without prior notice. Pentair is an equal opportunity employer.

4003261 REV A MY14 © 2014 Pentair Residential Filtration, LLC. All Rights Reserved.