

M-line



Easy Drain®
by ess

M-line



INSTALLATION MANUAL

FOR CONCRETE AND WOODEN FLOORS

-  Installation manual
-  Consejo para la instalación
-  Conseils de montage



CONTENTS

Contenido

Table des matières

Installation options	3
Installation guide	4
Sealing advice	15
Cleaning	21
Important assembling advice	22

M1

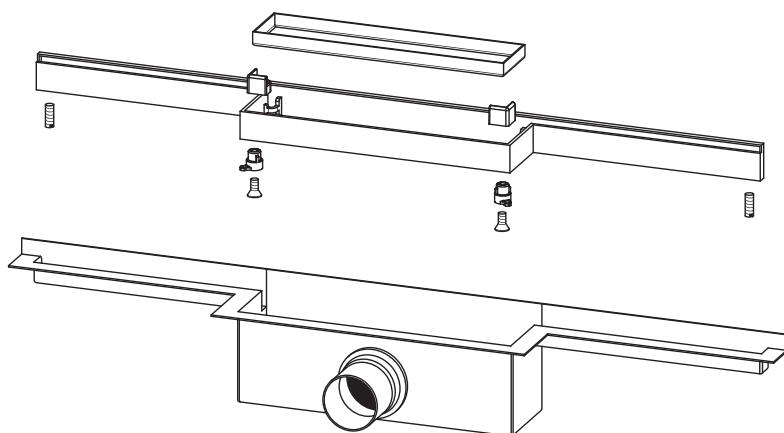

M4

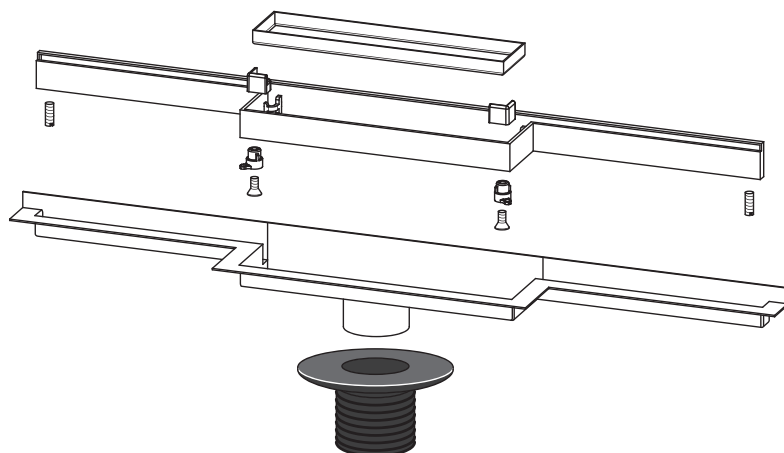

INSTALLATION OPTIONS

Opciones de instalación

Variantes de montaje

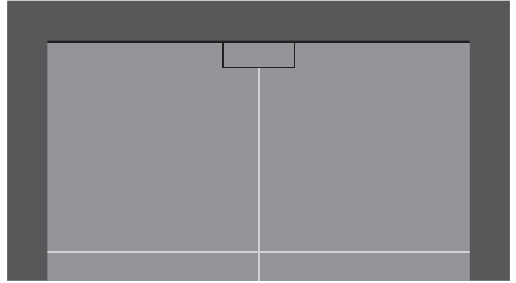
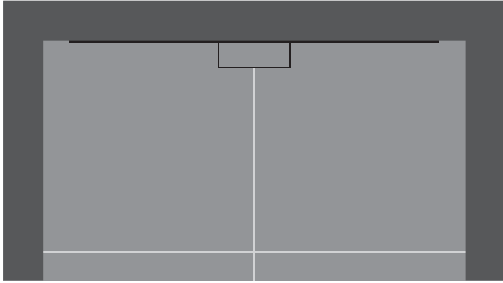

M1

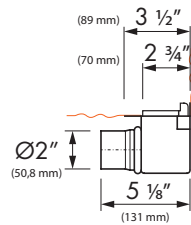
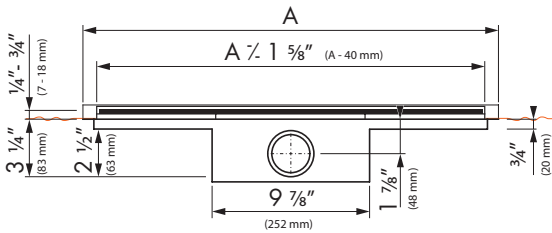
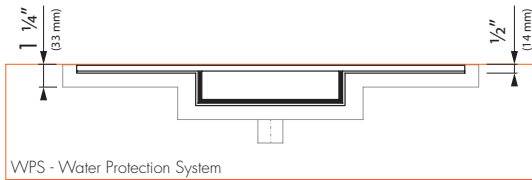

M4

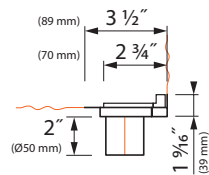
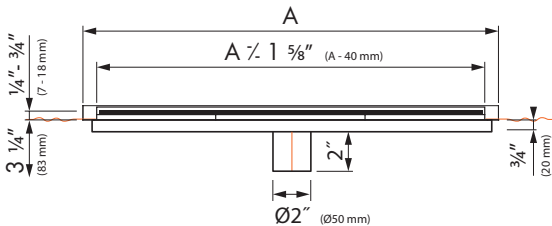
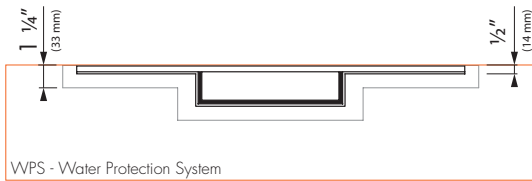

INSTALLATION GUIDE - CLAMP DRAIN - VERTICAL OUTLET (M4)

Manual de instalación

Explications de montage

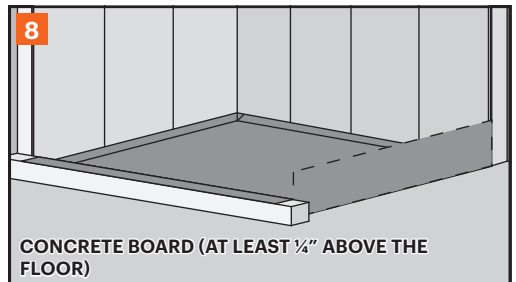
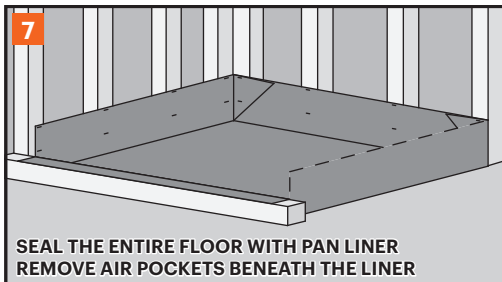
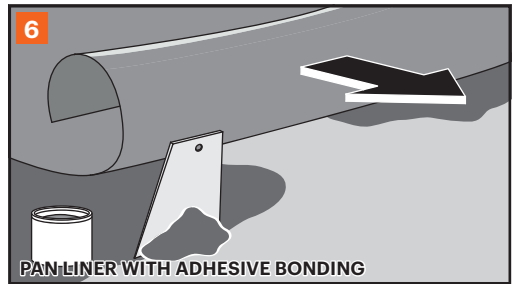
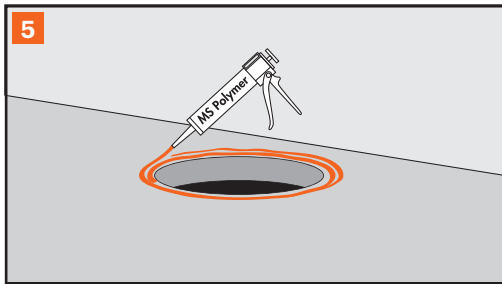
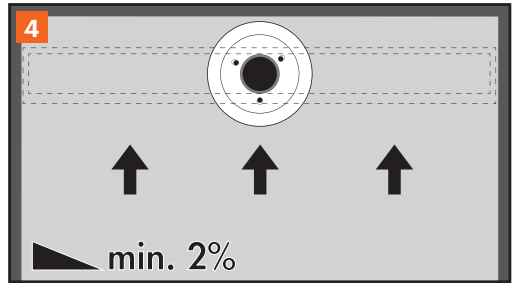
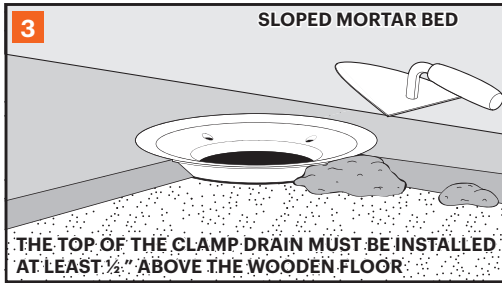
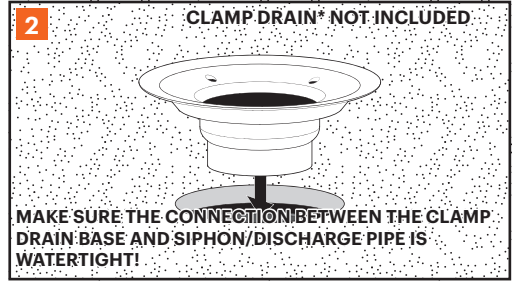
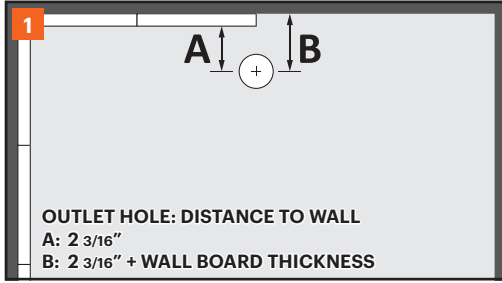

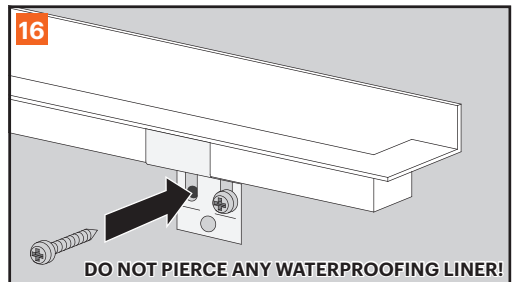
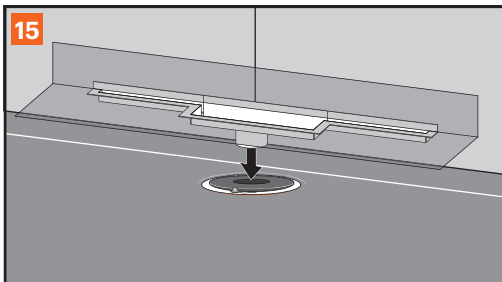
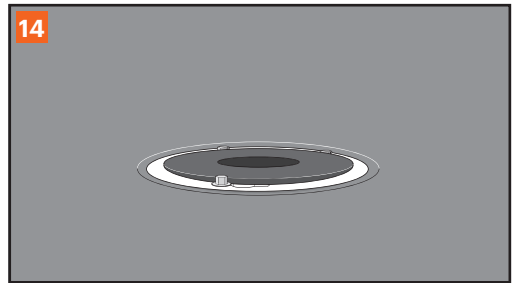
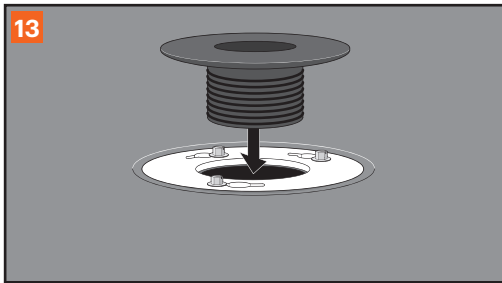
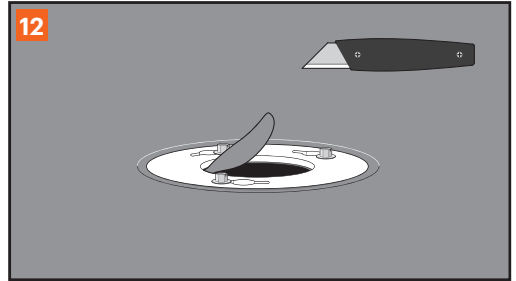
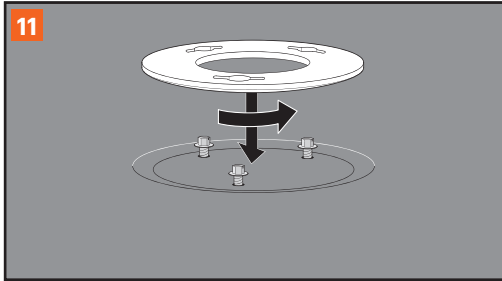
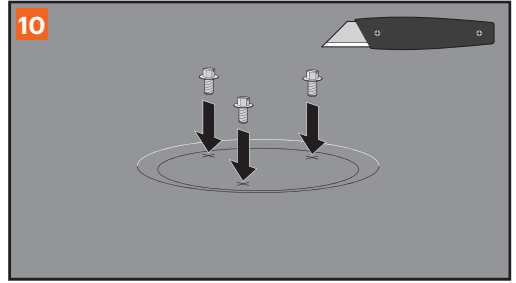
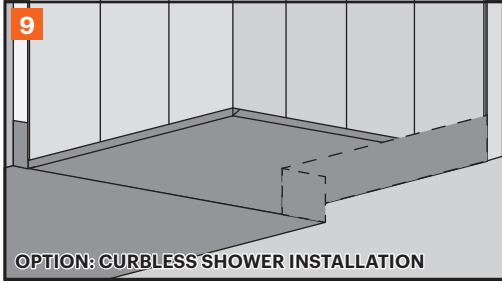

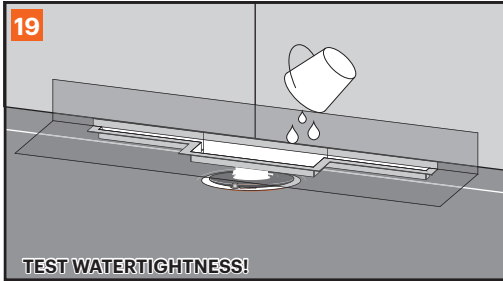
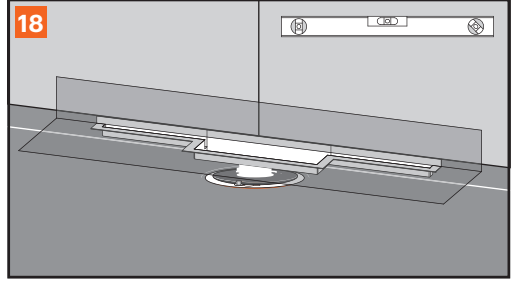
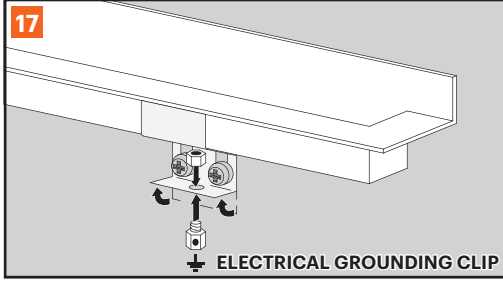

CONTINUE WITH IMAGE 1 ON PAGE 11

INSTALLATION GUIDE - NO-HUB SLEEVE - VERTICAL OUTLET (M4)

Manual de instalación

Explications de montage

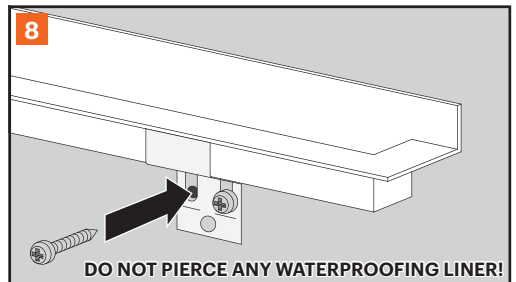
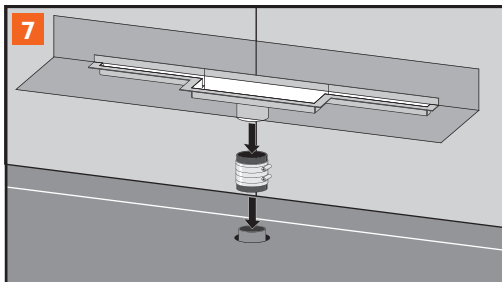
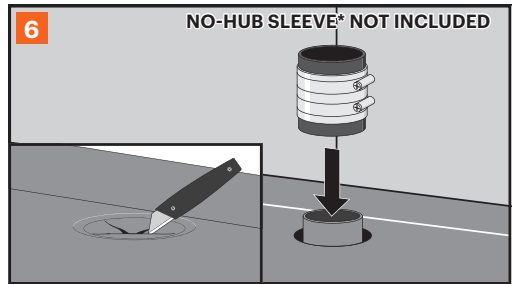
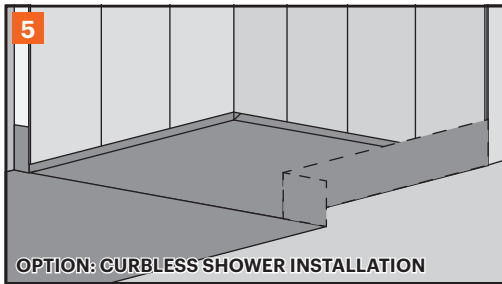
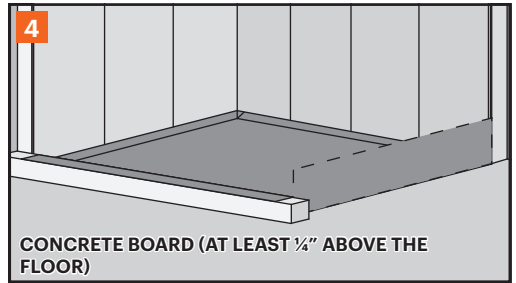
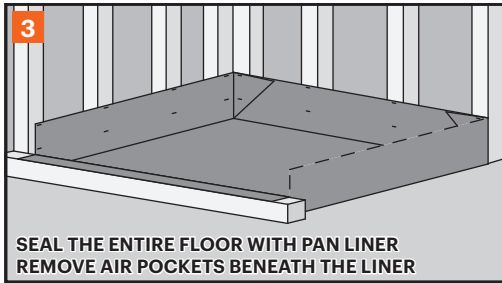
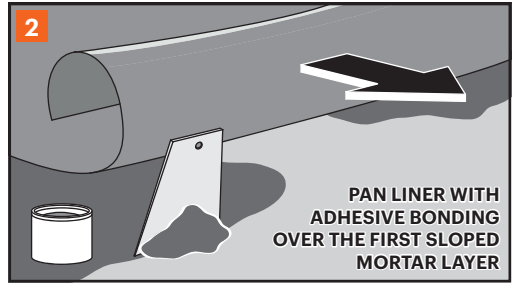
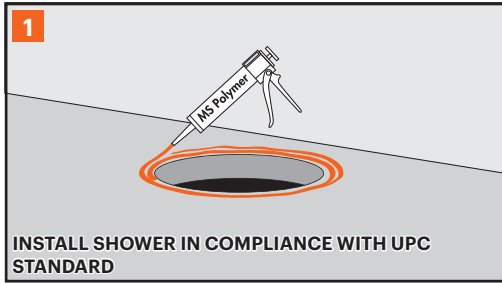

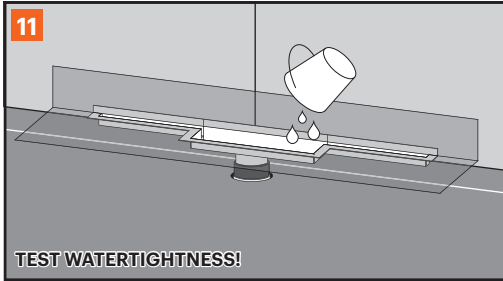
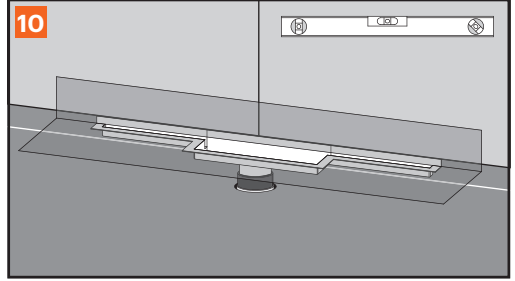
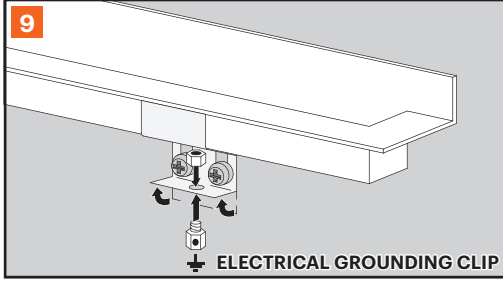

CONTINUE WITH IMAGE 1 ON PAGE 11

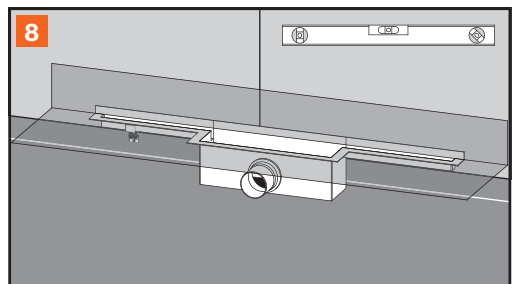
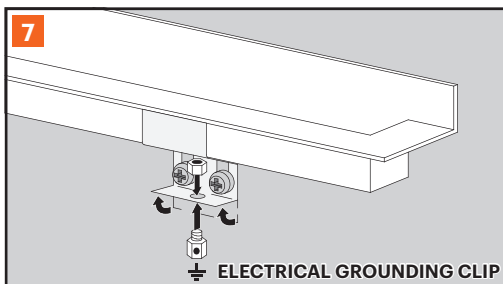
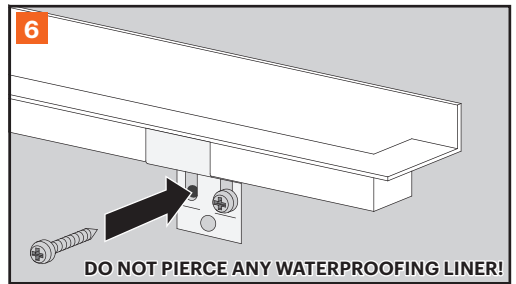
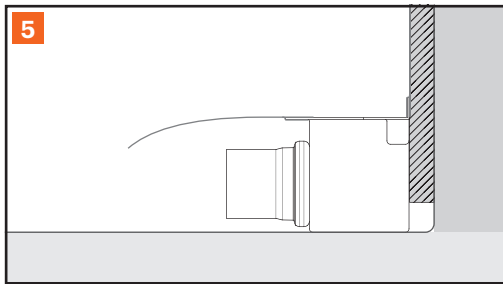
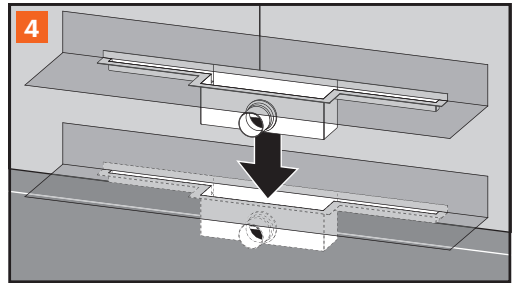
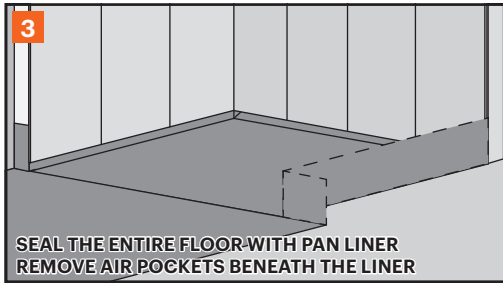
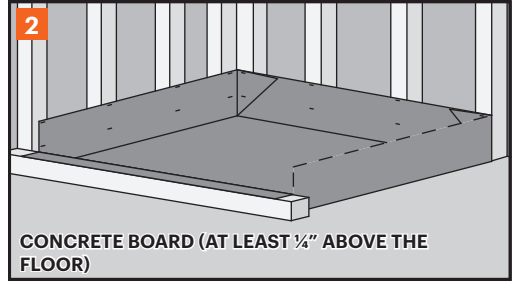
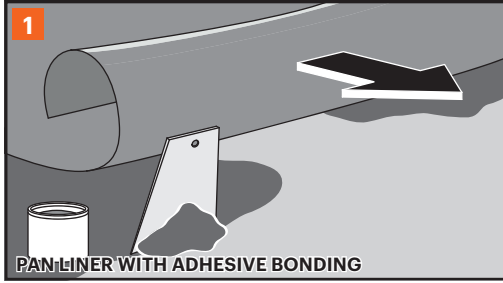

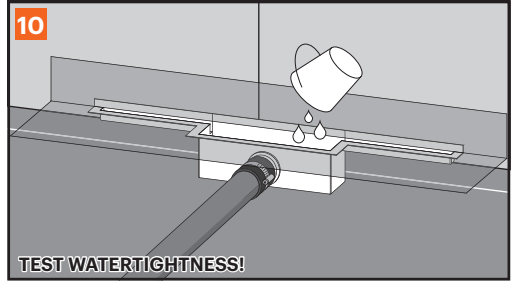
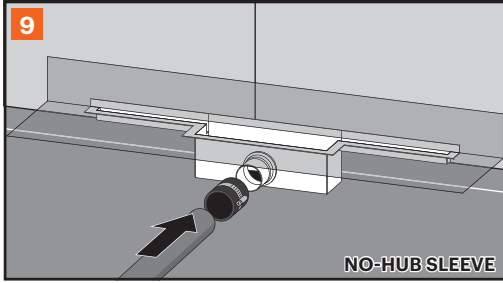

CONTINUE WITH IMAGE 1 ON PAGE 11

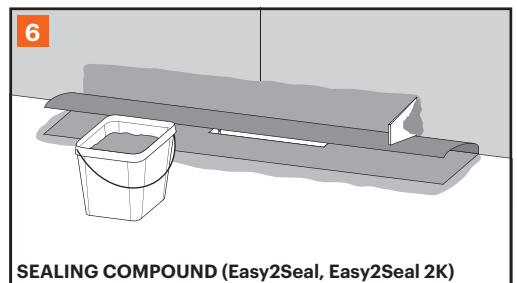
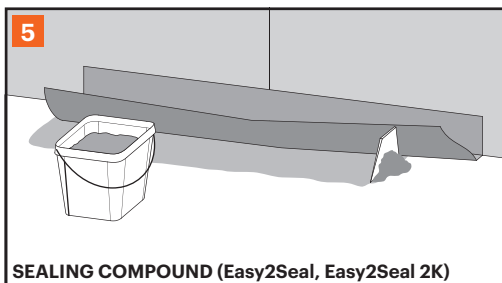
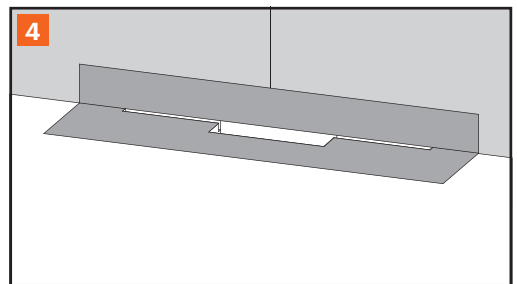
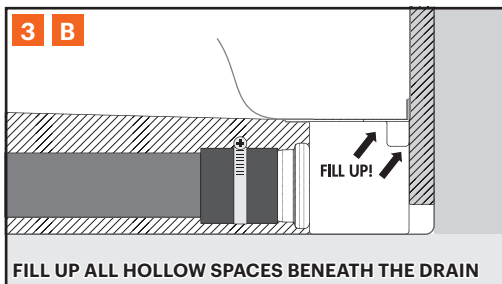
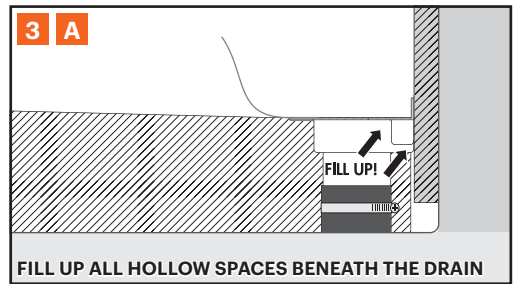
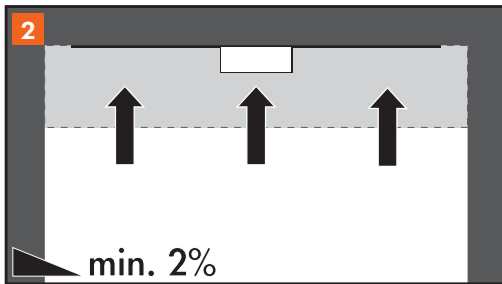
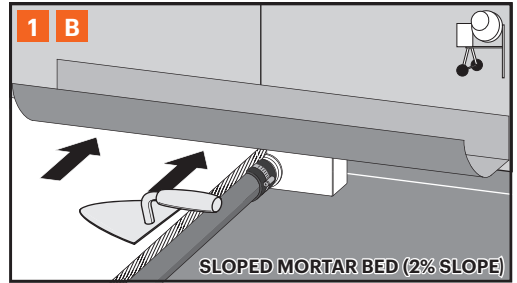
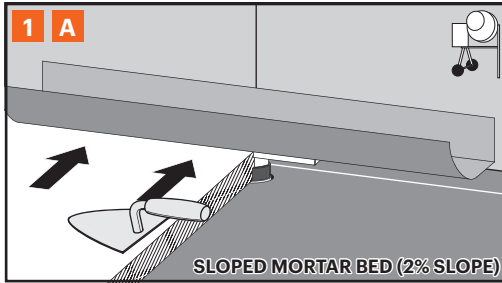

Easy Drain®

by ess

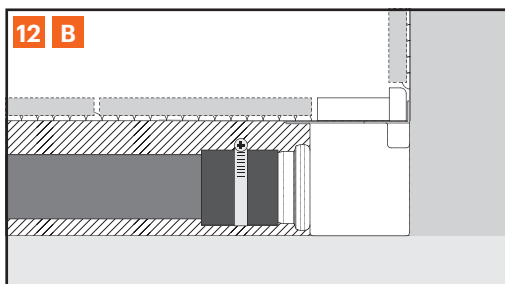
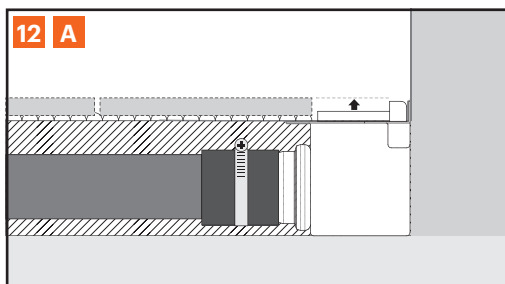
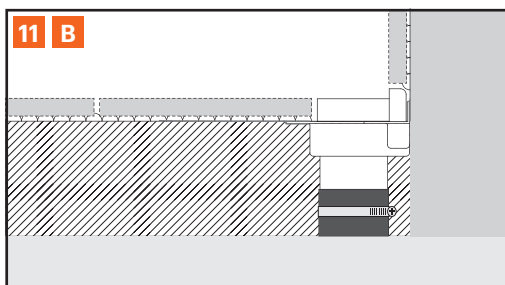
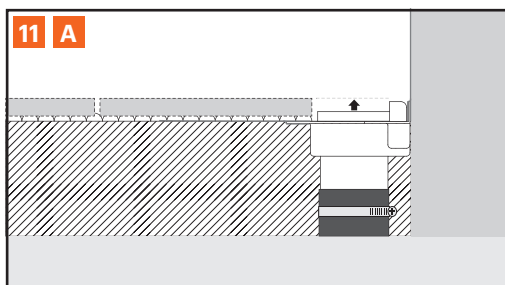
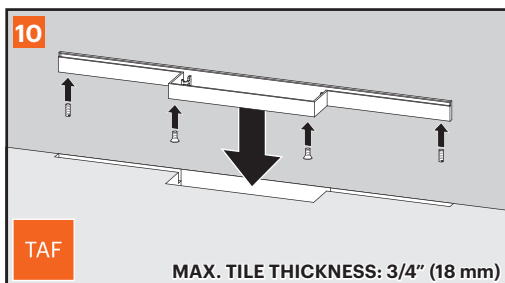
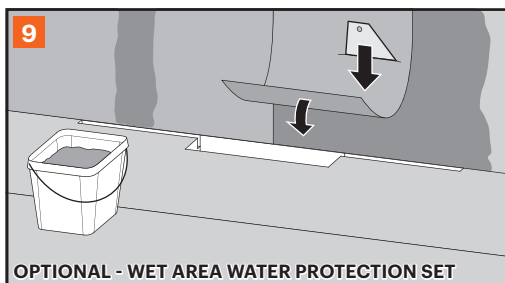
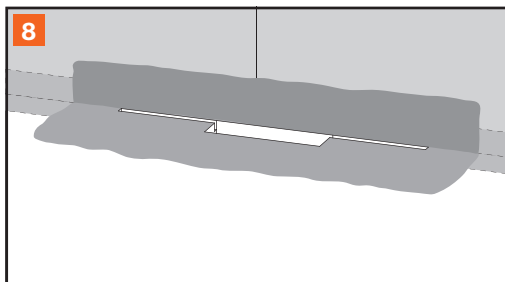
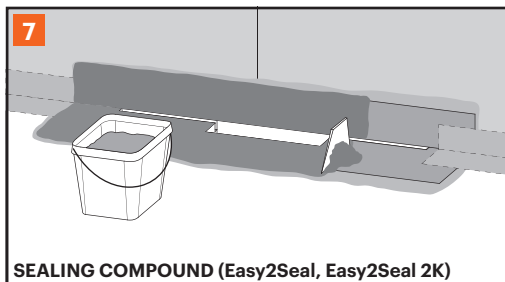

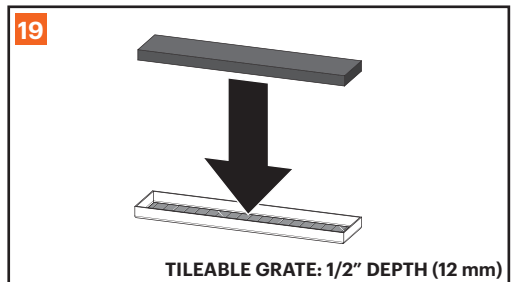
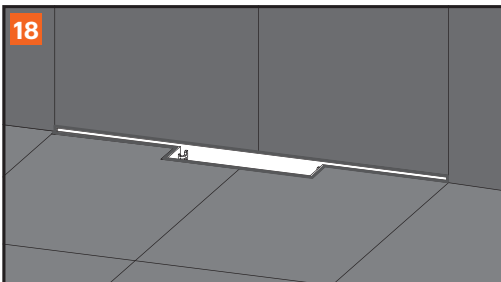
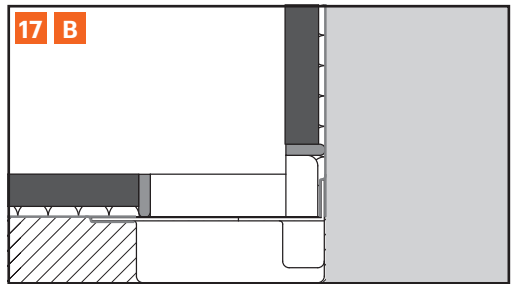
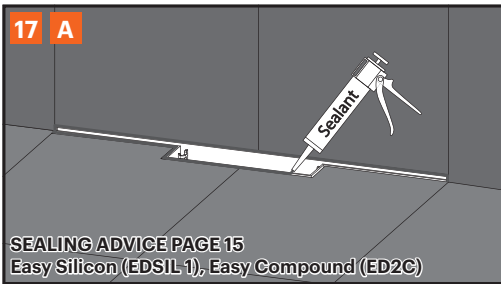
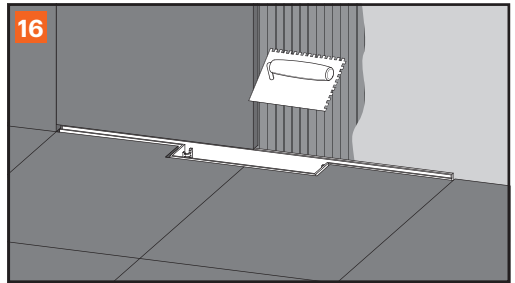
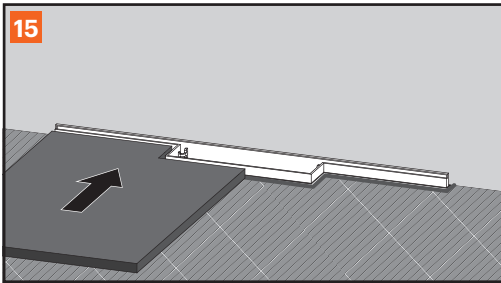
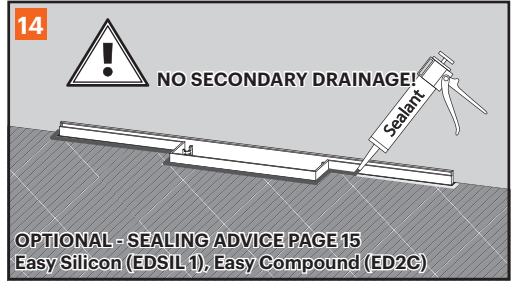
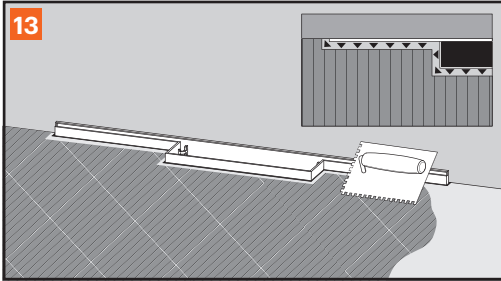

Easy Drain®

by ess

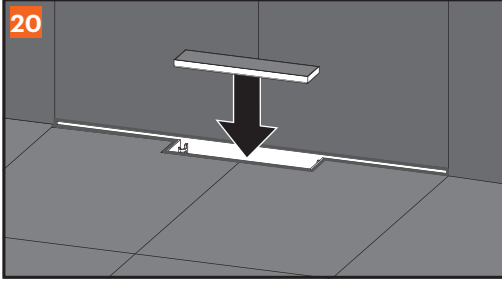

SEALING ADVICE - CLAMP DRAIN - VERTICAL OUTLET (M4)

Consejo de sellado

Conseil pour étanchéifier

ONLY PRIMARY DRAINAGE

Sólo desagüe de agua primario

Seule évacuation primaire

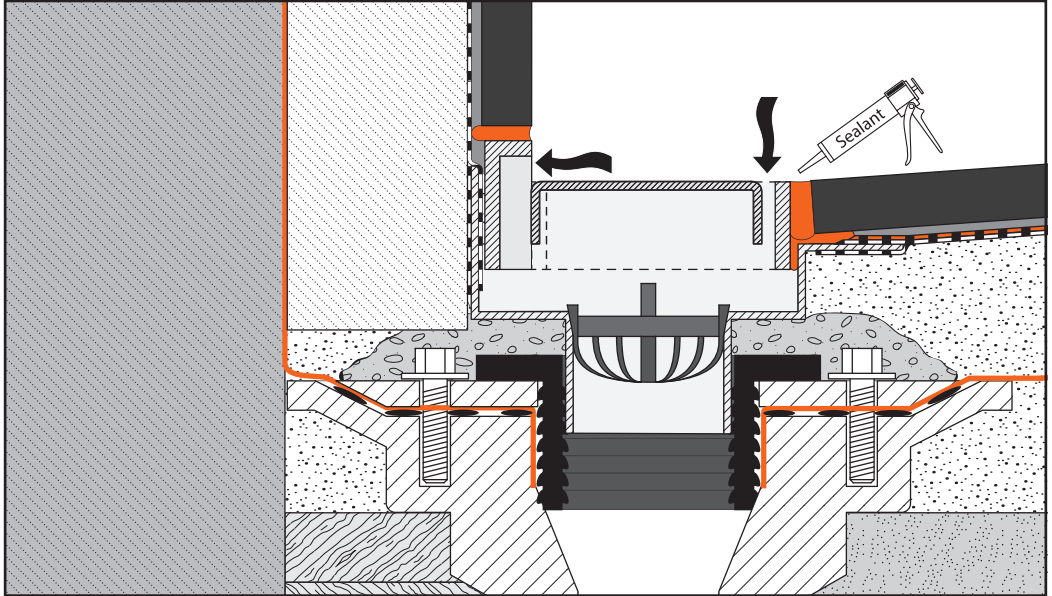

WITH SECONDARY (UNDERTILE) DRAINAGE

Con desagüe de agua secundario

Avec évacuation secondaire

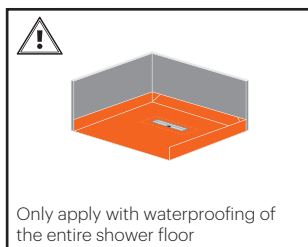
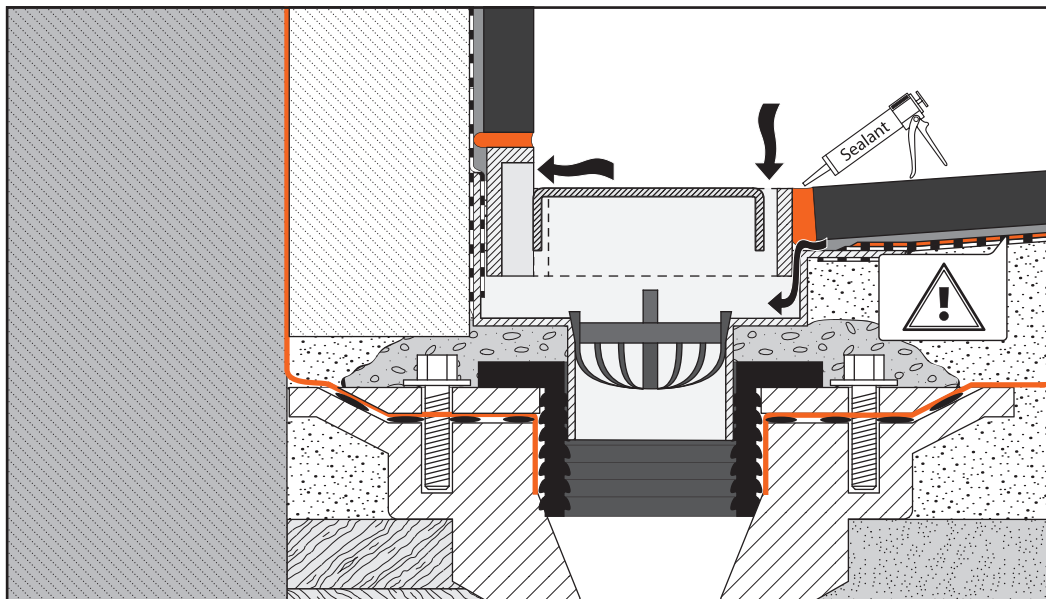

SEALING ADVICE - NO-HUB SLEEVE - VERTICAL OUTLET (M4)

Consejo de sellado

Conseil pour étanchéfier

ONLY PRIMARY DRAINAGE

Sólo desagüe de agua primario

Seule évacuation primaire

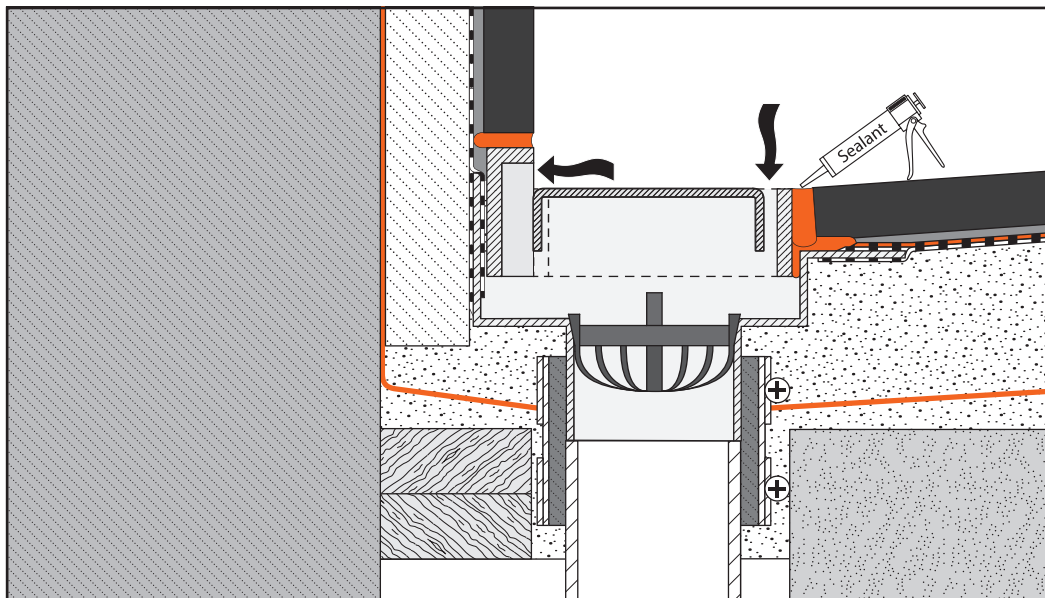

WITH SECONDARY (UNDERTILE) DRAINAGE

Con desagüe de agua secundario

Avec évacuation secondaire

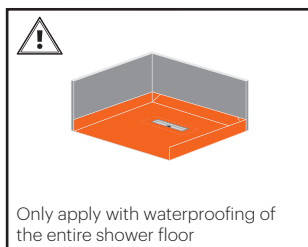
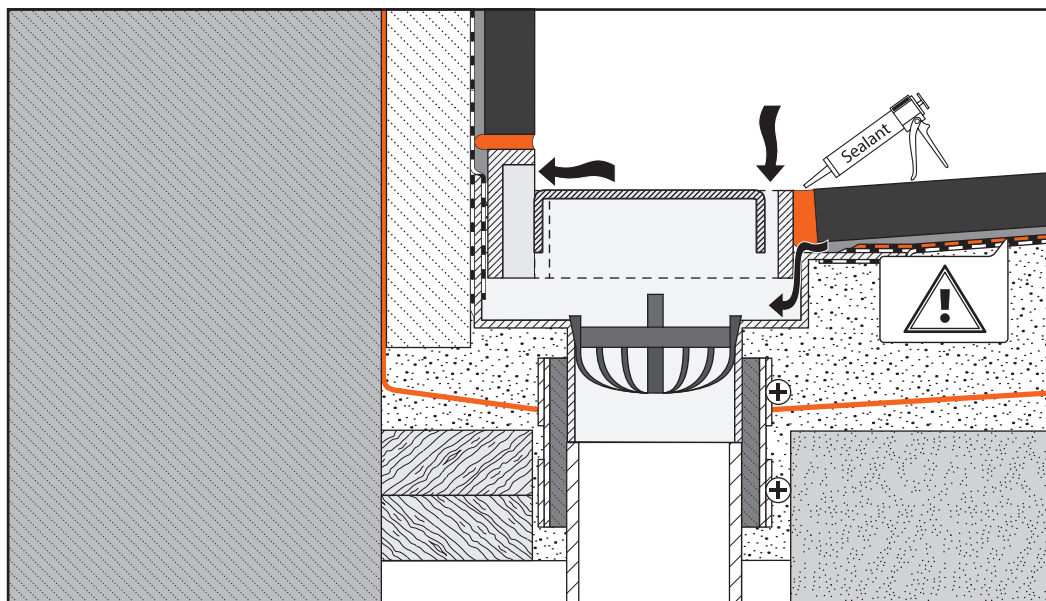

SEALING ADVICE - HORIZONTAL OUTLET (M1)

Consejo de sellado

Conseil pour étanchéifier

ONLY PRIMARY DRAINAGE

Sólo desagüe de agua primario

Seule évacuation primaire

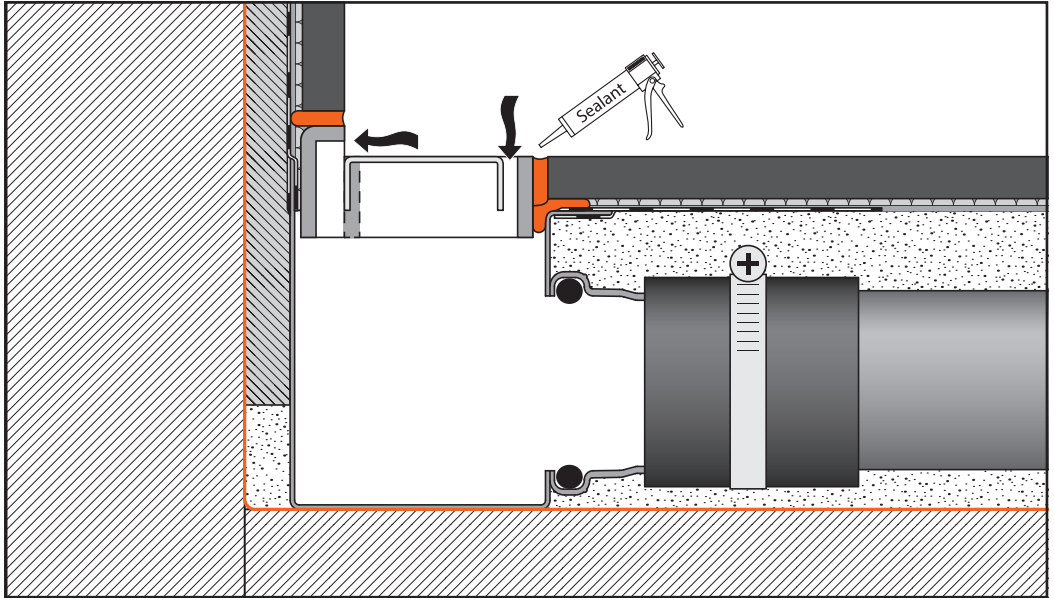

WITH SECONDARY (UNDERTILE) DRAINAGE

Con desagüe de agua secundario

Avec évacuation secondaire

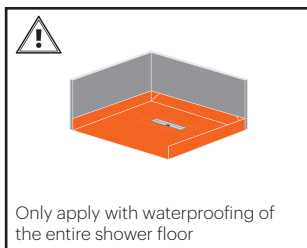
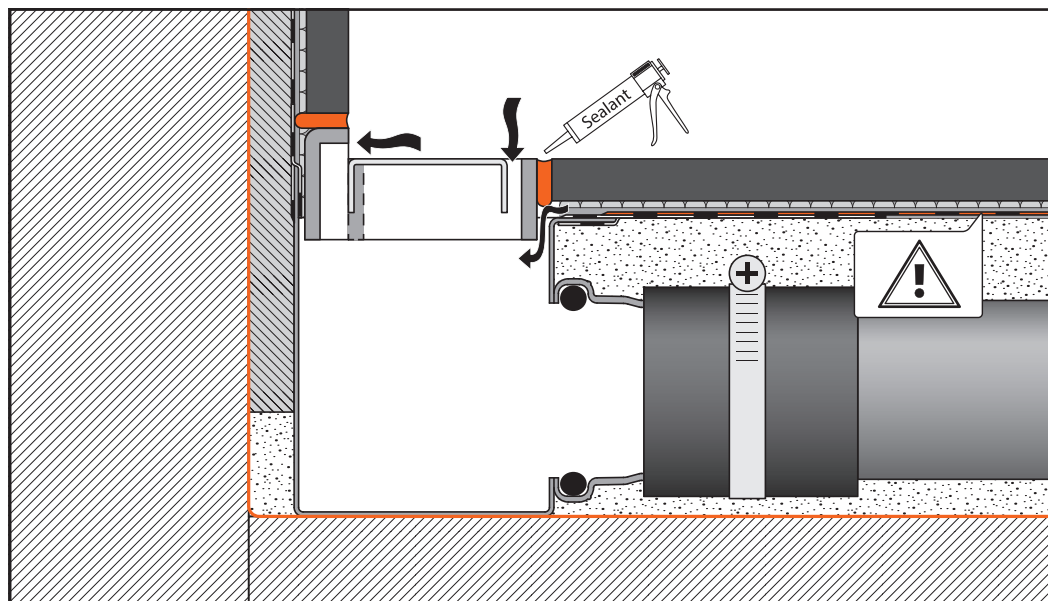

CLEANING - VERTICAL OUTLET (M4)

Limpeza

Nettoyage du siphon

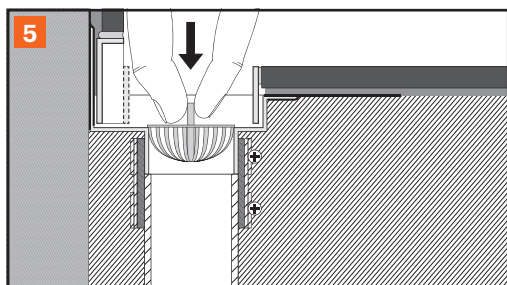
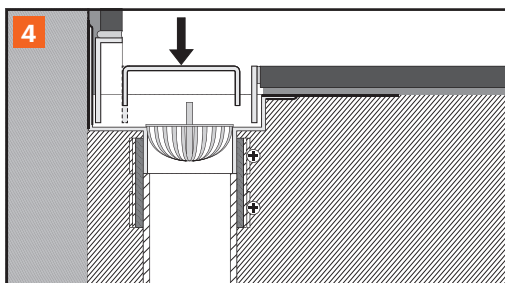
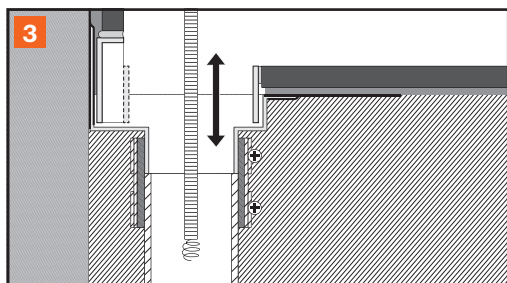
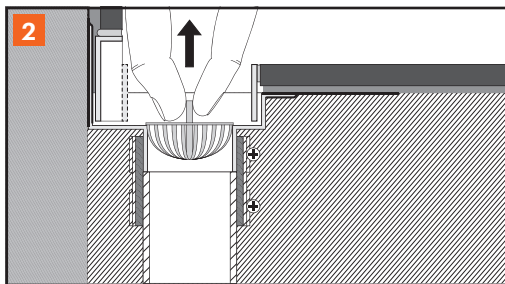
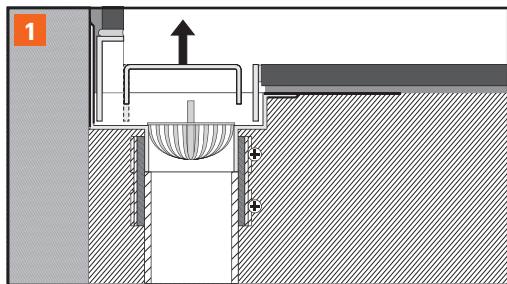

CLEANING - HORIZONTAL OUTLET (M1)

Limpeza

Nettoyage du siphon

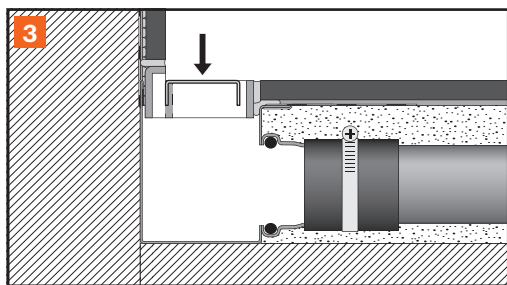
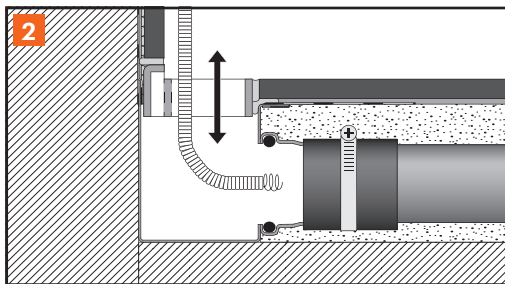
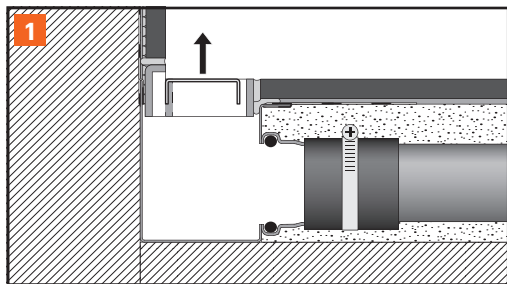

Important assembling advice: Easy Drain®

Suitable for renovation work and new construction

The shower drain should only be installed by specialist companies in compliance with the building regulations. To achieve the best possible result, please carefully read the installation guide. If you have any questions, please consult your supplier.

- Please check the content of the package for completeness and integrity before proceeding with the assembly. Do not install the drain if any deviations are noted. Should this be the case, please consult your supplier.
 - Prior to construction, the installation procedure and its special considerations should be discussed with the tile setter. After the installation of the drain body (rough) is complete, please provide the tile setter with the complete installation guide.
 - If the drain is used for large showers with multiple heads, please check to make sure that the drainage capacity is sufficient. If you are unsure, please consult the supplier for advice.
 - If you do not wish to use the second drainage level (secondary water drainage), the joint between the shower drain body and the TAF (tile frame) should be sealed with a permanent sealer.
 - We recommend taping or closing the drain opening of the shower drain with a cement cap prior to the assembly to prevent construction debris from getting into the drainage pipe. To prevent damage to the TAF (tile frame), it should be kept in the package until the final installation by the tiler.
 - Make sure the drain is level all around.
 - Install the sewage system in compliance with the local and national codes. **Note:** ensure that the sewage system is properly vented and correctly pitched.
 - Check the drainage system and the sewer system connection for water tightness.
 - In order to prevent hollow spaces, all empty space beneath the drain must be completely filled up and sealed with floor pavement up to the top edge of the drain flange.
 - The seal must be in compliance with the state and local standards.
 - When tiles are being fitted, the pitch of the tiles (min. 2% per 3'3" (=1m)) in the shower must always be sloped towards the drain. The tiles should be laid level or 3/64" (=1 mm) higher than the top edge of the tile frame to ensure good drainage toward the shower drain.
- Note:** the requirements with regard to the floor gradient may be different for walk-in showers with glass walls. Please consult your supplier in this respect.
- Once the tiles have been fitted, the joint between the tiled floor and the TAF (tile frame) should be permanently sealed with an elastic sealant (maintenance joint). The adhesion surfaces should be free of mortar, adhesive and other adhesion-reducing materials.
 - The drain is only intended for use with waste water common in households. Do not use other fluids as well as cleaning agents with the potential to damage sanitary equipment, drainage equipment and raw materials.
 - If the drain is used for other purposes (e.g. swimming pools), where it may come in contact with aggressive cleaning agents or corrosive substances such as salt or chlorine, please consult your supplier.
 - Construct the floor according to state and local building codes.
 - Compliance with this installation advice is required for any warranty claims. Deviation from the installation instructions will void the warranty.

Caution !

- Tile cleaning products often contain aggressive chemicals that are abrasive in nature and may damage the drain. Please ensure that the drain is thoroughly flushed after using any tile and grout cleaning products.
- 10 Years limited warranty only applies when constructed according to all installation instructions.
- Glass gratings are not suited for wheelchair accessibility.

MAINTENANCE INSTRUCTIONS

- Do not use abrasives and/or sharp/scraping objects to clean the Easy Drain®.
- The hair catcher should be cleaned periodically to remove any dirt that may have collected.
- We recommend the use of Easy CLEANSET for daily maintenance and cleaning of your Easy Drain®.

Indicaciones importantes de colocación: Easy Drain®

Adecuado tanto en los edificios de nueva construcción como en la de renovación

Únicamente una empresa especializada puede colocar el drenaje o desagüe de ducha y siempre teniendo en cuenta las disposiciones técnicas de instalación. Para que la colocación resulte satisfactoria, lea las indicaciones de montaje cuidadosamente. En caso de consultas, póngase en contacto con su proveedor.

- Antes de comenzar con el montaje, verifique que la caja esté completa y que su contenido esté íntegro. Si hubiera diferencias, no coloque el desagüe. En ese caso, contáctese con su proveedor.
- Antes de comenzar con el montaje, converse las particularidades de las indicaciones de colocación con el colocador de baldosas. Después de la colocación, entréguele las indicaciones de montaje del drenaje al colocador de baldosas.
- En caso de utilizar el drenaje para varias duchas, verifique que la capacidad de descarga del desagüe de la ducha sea suficiente. Si fuese necesario, solicite asesoramiento a su proveedor.
- Si el segundo nivel de salida no será utilizado (desagüe de agua secundario), selle la junta entre el cuerpo del drenaje de la ducha y el marco de baldosas con material impermeable duradero.
- Le recomendamos que adhiera el orificio de salida del desagüe de la ducha antes del montaje, para evitar que el desagüe de salida se ensucie. Para evitar roturas, el marco de baldosas debe permanecer en la caja hasta que el colocador de baldosas termine con el montaje final.
- Coloque las patas de apoyo y nivele el drenaje de la ducha en forma horizontal en todas las direcciones. En una de las mordazas de anclaje, fije la puesta a tierra.
- La instalación del equipo de desagüe debe realizarse conforme a las normas. **Nota:** tenga en cuenta la aireación y la ventilación y que el declive del desagüe sea suficiente.
- Controle la estanqueidad del sistema de desagüe de la ducha y de las conexiones del desagüe.
- Llenar e impermeabilizar el cuerpo del drenaje completamente hasta el borde superior de la brida y el solado para que quede estanco y evitar espacios vacíos.
- Al colocar las baldosas del suelo, el desnivel de las baldosas (mínimo 2% cada m²) del área de la ducha siempre debe correr hacia el desagüe de la ducha. Las baldosas deben colocarse a la misma altura o 1mm más arriba del borde superior del marco de las baldosas. De esta manera, se garantiza un buen desagüe hacia el drenaje de la ducha. **Nota:** en caso de duchas en el mismo nivel del suelo con paneles de vidrio, es posible que para los desniveles sea necesario tener en cuenta otros requisitos. Consulte a su proveedor al respecto.
- Después de colocar las baldosas, el paso entre el suelo de baldosas y el drenaje de la ducha debe impermeabilizarse con una junta elástica (junta de dilatación) en forma permanente. Las superficies adherentes deben estar libres de mortero, adhesivo y otros materiales que disminuyan la adhesión.
- El sistema de desagüe de la ducha solo es apto para desagotar las duchas habituales para el hogar. Evite cualquier otro líquido, tales como productos de limpieza, que puedan dañar los elementos del equipamiento, del desagüe y el material de los caños.
- Si se utiliza el desagüe de la ducha en otras áreas (por ejemplo, en piscinas), en las que el drenaje entre en contacto con productos de limpieza agresivos o substancias corrosivas, tales como sal o cloro, póngase en contacto con su proveedor.
- Seguir esta recomendación de montaje es requisito para hacer uso del derecho de garantía, de acuerdo con nuestras condiciones de venta y de entrega.

Atención !

- Frecuentemente, los productos de limpieza de baldosas contienen químicos agresivos, que pueden dañar la superficie del drenaje. Tenga en cuenta que, si utiliza productos de limpieza de baldosas y juntas, posteriormente deberá limpiar profundamente el drenaje de la ducha.

Instrucciones de mantenimiento

- Limpiar el Easy Drain® sin utilizar productos corrosivos y/o materiales abrasivos.
- Limpiar periódicamente los posibles residuos del cierre hidráulico.
- Se recomienda el uso de EasyClean Set (ED-SC) para el mantenimiento diario y limpieza intensiva de su Easy Drain®.

Queda reservado cualquier error de impresión y de redacción. Queda excluida cualquier responsabilidad de Easy Sanitary Solutions BV por daños que se produzcan por el uso y/o colocación del drenaje de la ducha. Easy Sanitary Solutions BV queda eximida de cualquier responsabilidad a priori.

Consignes de montage importantes: Easy Drain®

Pour les nouvelles constructions et pour les projets de rénovation

Le montage du caniveau de douche devra, dans le respect des règles de la construction, être réalisé uniquement par une entreprise spécialisée. Pour obtenir un résultat optimal, veuillez lire attentivement les instructions de montage. Pour toutes questions éventuelles, veuillez consulter votre fournisseur.

- Avant d'entreprendre le montage, il est nécessaire de vérifier que le contenu de l'emballage est complet et intact. Si tel n'est pas le cas, le caniveau de douche ne devra pas être installé. Veuillez alors prendre contact avec votre fournisseur.
 - Avant d'entreprendre le montage, il est nécessaire de discuter avec le carreleur des consignes de montage et de leurs particularités. Après le montage, veuillez remettre toutes les consignes de montage au carreleur.
 - Si le caniveau de douche doit desservir plusieurs douches, veuillez vérifier qu'il présente une capacité d'écoulement suffisante. Le cas échéant, demandez conseil à votre fournisseur.
 - En cas de non-utilisation du deuxième niveau d'écoulement (évacuation secondaire), le joint entre le corps du caniveau de douche et le cadre à carrelé devra être colmaté au moyen d'un mastic d'étanchéité durable.
 - Nous vous recommandons, avant de procéder au montage, d'obtenir l'orifice d'écoulement du caniveau de douche avec un ruban adhésif pour prévenir la présence de souillures dans la canalisation d'écoulement. Pour éviter les détériorations, le cadre à carrelé devra rester dans son emballage jusqu'à son montage final par le carreleur.
 - Monter les pieds de réglage en hauteur et ajuster le caniveau de douche à l'horizontale dans toutes les directions. Fixez la mise à la terre sur l'une des agrafes d'ancrage.
 - La mise en place de l'installation d'écoulement devra être réalisée conformément aux normes. **Remarque:** Tenez compte de l'aération et veillez à donner une déclivité suffisante à l'installation d'évacuation d'eau.
 - Vérifier l'étanchéité du système de caniveau de douche et des raccordements d'eaux usées.
 - Pour éviter la formation de cavités, il est nécessaire de mettre en œuvre le mortier de chape sous toute la surface du corps du caniveau, jusqu'à l'arête supérieure de la bride, et de le tasser.
 - L'étanchéité sera réalisée suivant les règles de l'art conformément à la fiche ZDB 8/2012 « Étanchéifications composites ». En cas d'utilisation d'autres matériaux d'étanchéité à titre d'alternative, il est nécessaire de tenir compte des informations produit des fabricants.
 - Lors de la pose du carrelage de sol, la déclivité (au min. 2% par m²) dans la zone de douche devra toujours être orientée vers le caniveau de douche. Les carrelages posés doivent affleurer l'arête supérieure du cadre à carrelé ou dépasser celle-ci de 1 mm, ce qui garantit un bon écoulement de l'eau vers le caniveau de douche.
- Remarque:** dans les douches de plain-pied à parois vitrées, il est possible que la déclivité obéisse à d'autres exigences. Sur ce point, veuillez vous adresser à votre fournisseur.
- Après la pose du carrelage, il est nécessaire d'étanchéifier durablement le joint entre le sol carrelé et le caniveau de douche au moyen d'un joint élastique (joint d'entretien). Les surfaces de collage doivent être exemptes de mortier, de colle et autres substances susceptibles de nuire à l'adhérence.
 - Le système de caniveau de douche est uniquement apte à recevoir les eaux usées domestiques habituelles. Évitez tous autres liquides tels que les produits de nettoyage susceptibles d'endommager les équipements sanitaires, les dispositifs d'évacuation d'eau et le matériel des tuyauteries.
 - En cas d'utilisation du caniveau de douche dans d'autres domaines (piscine, par exemple) dans lesquels il pourrait se trouver en contact avec des produits de nettoyage agressifs ou des substances favorisant la corrosion, telles que le sel ou le chlore, veuillez prendre contact avec votre fournisseur.
 - Le respect des présentes recommandations de montage est la condition préalable de l'exercice du droit à la garantie sur la base de nos Conditions générales de vente et de livraison.

Attention !

- Les produits nettoyants pour carrelages contiennent souvent des substances chimiques agressives. Ces substances peuvent attaquer la surface du caniveau. En cas d'utilisation de produits nettoyants pour carrelages et pour joints, veillez à procéder ensuite à un nettoyage suffisant du caniveau.

Instructions d'entretien

- N'utilisez pas de produit abrasifs ni d'objets coupants ou abrasifs pour le nettoyage du Easy Drain®.
- Éliminez périodiquement les dépôts éventuels au niveau du coupe-odeur.
- Nous conseillons d'utiliser EasyClean Set (ED-SC) pour la maintenance quotidienne et le nettoyage intensif du Easy Drain®.

Sous réserve de fautes d'impression. Easy Sanitary Solutions BV n'assume aucune responsabilité pour tous dommages résultant de l'utilisation et/ou du montage du caniveau de douche. Easy Sanitary Solutions BV exclut d'avance toute responsabilité.

Sales:

Easy Drain® USA Collection

561 Acom Street, Unit M

Deer Park, NY 11729

T: 001-(888) 317-7927

F: 001-(888) 488-1617

email: sales-usa@esspost.com

www.easydrainusa.com



Manufacturer:

Easy Sanitary Solutions

Nijverheidsstraat 60

7575 BK Oldenzaal, The Netherlands

tel: +31 (0)541 200800

email: info@esspost.com

www.easydrain.com

ESS PRODUCTS ARE PATENTED AND REGISTERED TRADEMARKS MADE BY ESS



E50.01.00.01.80

2019 rev.1