

PRODUCT SPECIFICATIONS

Elkay Mounting Frame with Filter Head Non-Filtered, Non-Refrigerated Galvanized Steel. Overall dimensions are 17-1/4" x 11-3/4" x 52-3/4". Made of Galvanized Steel.

Mounting Type:	Wall Mount (Inwall Frame/Plate)
Material:	Galvanized Steel
Finish:	Galvanized Steel
Dimensions:	17-1/4" x 11-3/4" x 52-3/4"
Shipping Weight:	35 lbs.

Special Note: For use with 115V LJNE models.

- For use with 115V LJNE models.



AMERICAN PRIDE. A LIFETIME TRADITION.
Like your family, the Elkay family has values and traditions that endure. For almost a century, Elkay has been a family-owned and operated company, providing thousands of jobs that support our families and communities.



Product Compliance: BUY AMERICAN ACT

[Installation Instructions \(PDF\)](#)

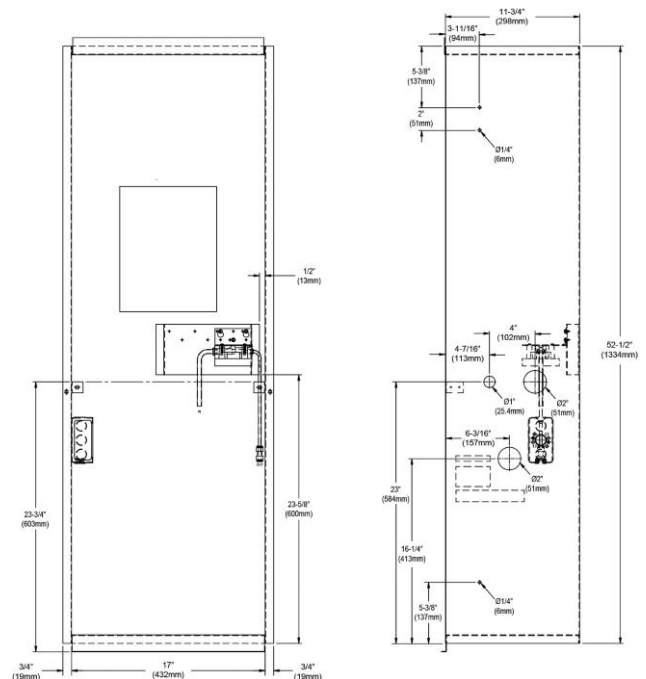

PART: _____ QTY: _____

PROJECT: _____

CONTACT: _____

DATE: _____

NOTES: _____

APPROVAL: _____

In keeping with our policy of continuing product improvement, Elkay reserves the right to change product specifications without notice. Please visit elkay.com for the most current version of Elkay product specification sheets. This specification describes an Elkay product with design, quality, and functional benefits to the user. When making a comparison of other producers' offerings, be certain these features are not overlooked.

MB23A Mounting Box Installation
Fountain with Cup Dispenser

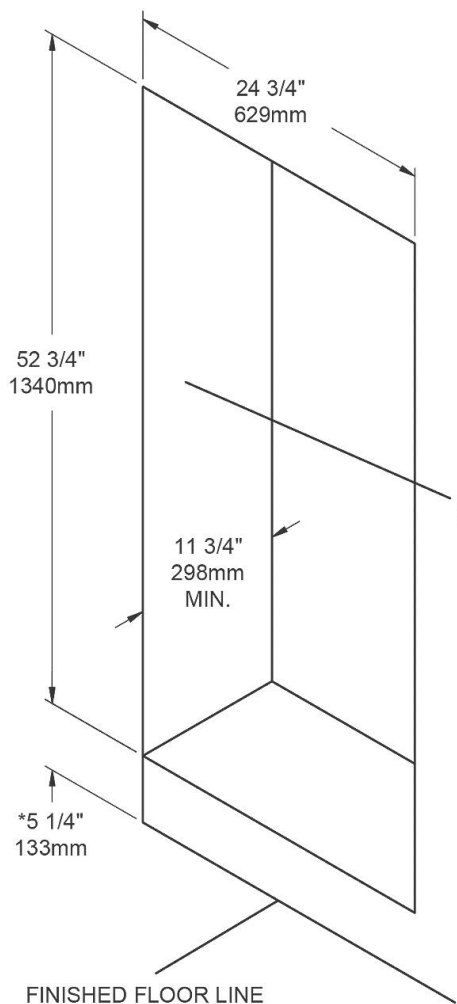

MB23A Mounting Box Installation
Fountain Only

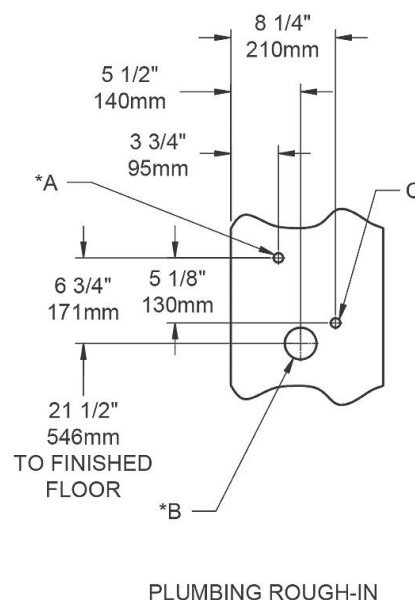
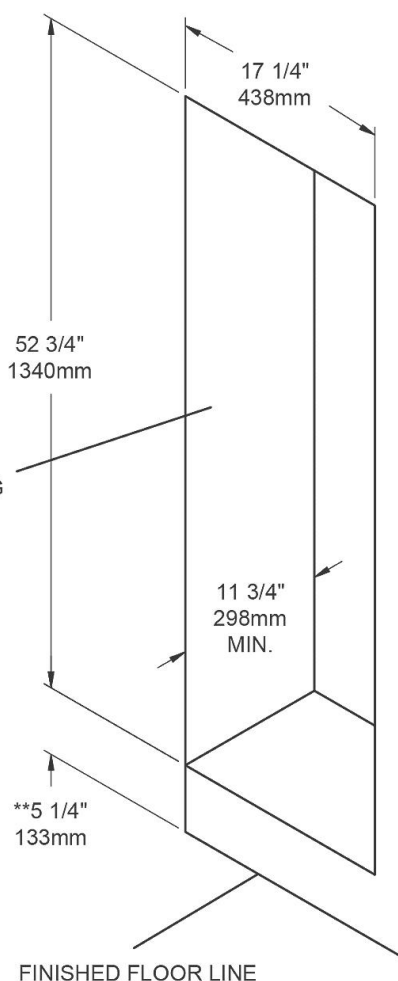

**Based on 34" (864mm) from finished floor to rim.
(39" (991mm) to centerline of glass filler)

LEGEND

- *A = Recommended water supply 3/8" (10mm) O.D. unplated copper tube connect, stub 1-1/2" (38mm) out from wall - shut off valve by others (left side only).
- *B = Recommended location for waste outlet 1-1/4" (32mm) O.D. drain (left side only).
- C = Electrical supply location (both sides).

NOTES:

1. There are holes and knockouts provided on each side of the mounting box that are intended to be used to mount the box. Use six screws or bolts (not provided).
- *2. Water and drain connections must be made from left side only.

In keeping with our policy of continuing product improvement, Elkay reserves the right to change product specifications without notice. Please visit elkay.com for the most current version of Elkay product specification sheets. This specification describes an Elkay product with design, quality, and functional benefits to the user. When making a comparison of other producers' offerings, be certain these features are not overlooked.