

PRODUCT SPECIFICATIONS

Elkay Soft Sides® Heavy Duty Single Fountain Non-Filtered, Non-Refrigerated Stainless. Features shall include Heavy Duty Vandal Resistant. Furnished with Vandal Resistant bubbler. Mechanical Front Bubbler Button activation. Product shall be Wall Mount (On Wall), for Indoor + Outdoor applications, serving 1 station(s). Unit shall be lead-free design which is certified to NSF/ANSI 61 & 372 (lead free) and meets Federal and State low-lead requirements.

Special Features:	Heavy Duty Vandal Resistant
Finish:	Stainless Steel
Power:	No Electrical Required
Bubbler Style:	Vandal Resistant
Activation by:	Mechanical Front Bubbler Button
Mounting Type:	Wall Mount (On Wall)
Chilling Option:	Non-refrigerated
Dimensions (L x W x H):	19-3/4" x 19-3/8" x 20-3/8"
Approx. Shipping Weight:	25 lbs.
Installation Location:	Indoor + Outdoor
No. of Stations Served:	1

Special Note: Requires In-Wall Carrier MPW101 (sold separately)

- Mechanically-Activated bubbler continues to supply water in event of service disruptions.



AMERICAN PRIDE. A LIFETIME TRADITION. Like your family, the Elkay family has values and traditions that endure. For almost a century, Elkay has been a family-owned and operated company, providing thousands of jobs that support our families and communities.



Included with Product: Fountain

PRODUCT COMPLIANCE

- ADA & ICC A117.1
- ASME A112.19.3/CSA B45.4
- Buy American Act
- NSF/ANSI 61 & 372 (lead free)



Complies with ADA & ICC A117.1 accessibility requirements when installed according to the requirements outlined in these standards. Installation may require additional components and/or construction features to be fully compliant. Consult the local Authority Having Jurisdiction if necessary.

[Installation Instructions \(PDF\)](#)

Water Systems are warranted for 12 months from date of installation. **Warranty pertains to drinking water applications only. Non-drinking water applications are not covered under warranty.**

[Warranty \(PDF\)](#)

OPTIONAL ACCESSORIES

EWF172 - WaterSentry VII Filter Kit (Coolers + Fountains)
MPW101 - Accessory - In Wall Carrier (Single) for EDFP210, EDFP214, EDFPB114, EDFPBW114, EHW214 models
AP99 - Elkay Access Panel 9" x 9" x 6"
98481C - Accessory - Bubbler Kit Water-Efficient Vandal-Resistant

PART: _____ QTY: _____

PROJECT: _____

CONTACT: _____

DATE: _____

NOTES: _____

APPROVAL: _____

In keeping with our policy of continuing product improvement, Elkay reserves the right to change product specifications without notice. Please visit elkay.com for the most current version of Elkay product specification sheets. This specification describes an Elkay product with design, quality, and functional benefits to the user. When making a comparison of other producers' offerings, be certain these features are not overlooked.

When installing EHW214C with MPW101 in-wall plate mounted directly to wall studs, refer to the diagrams shown below.

For electrical, waste, and water supply locations refer to the Installation/Owners manual.

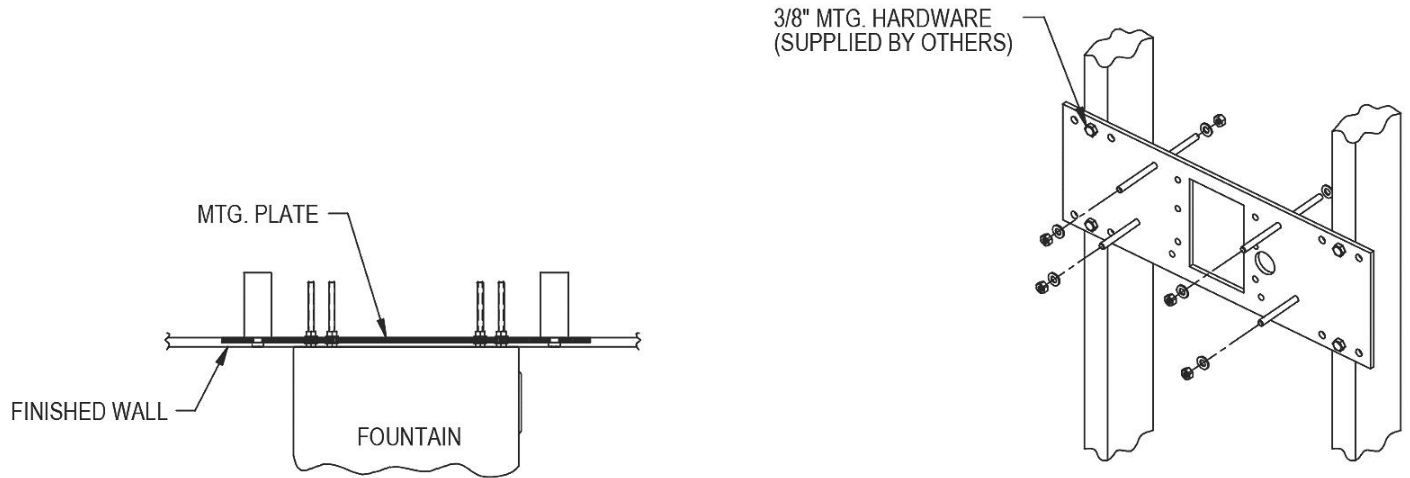

NOTE - AFTER INSTALLATION, THREADED RODS MAY NEED TO BE TRIMMED.

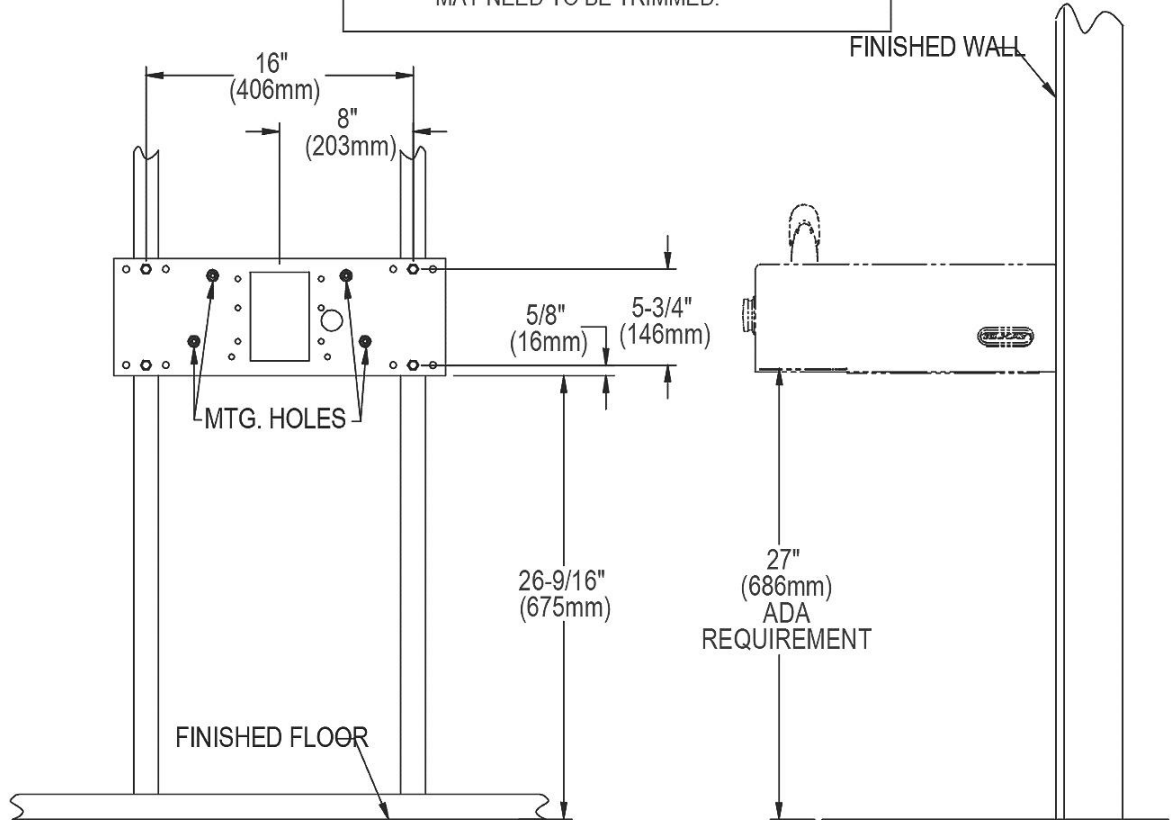

In keeping with our policy of continuing product improvement, Elkay reserves the right to change product specifications without notice. Please visit elkay.com for the most current version of Elkay product specification sheets. This specification describes an Elkay product with design, quality, and functional benefits to the user. When making a comparison of other producers' offerings, be certain these features are not overlooked.

When installing EHW214C with MPW101 in-wall plate and ML100 support legs, refer to the diagrams shown below.

For electrical, waste, and water supply locations refer to the Installation/Owners manual.

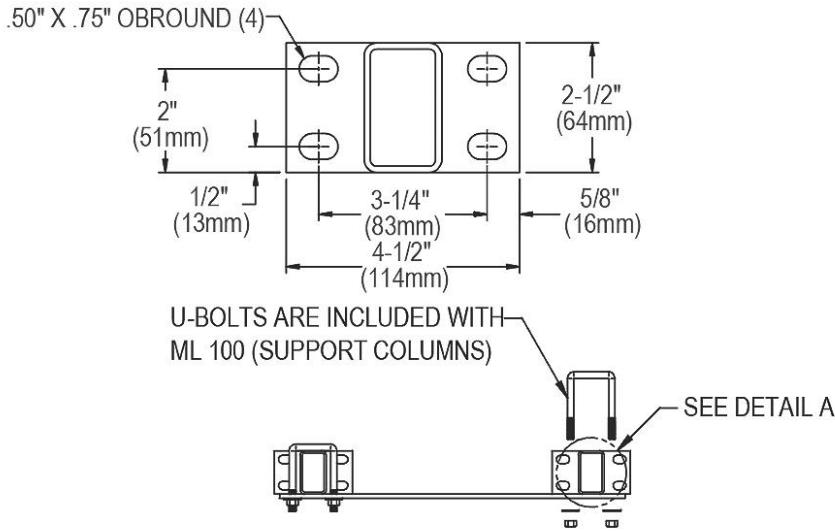

NOTE - AFTER INSTALLATION, U-BOLTS AND THREADED RODS MAY NEED TO BE TRIMMED.

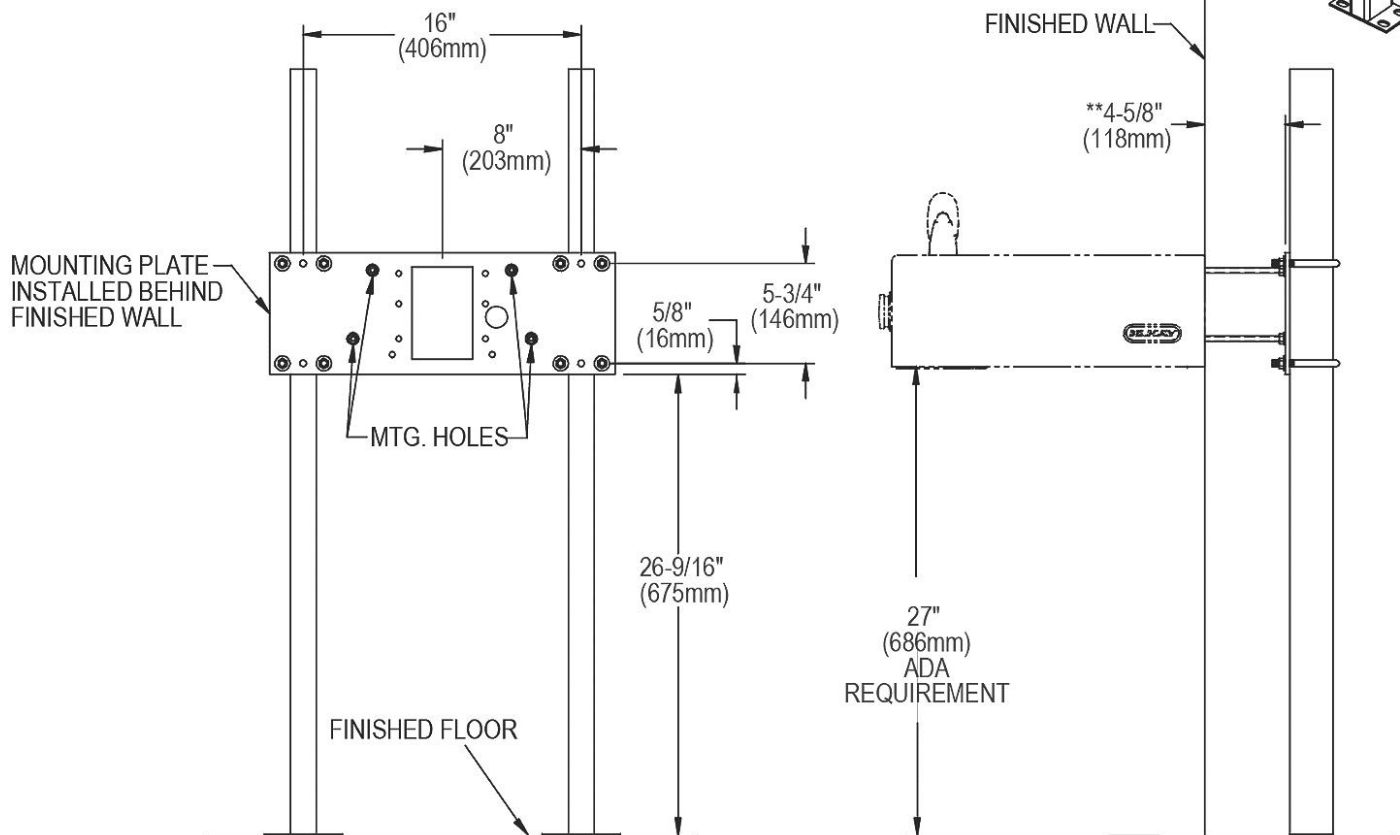
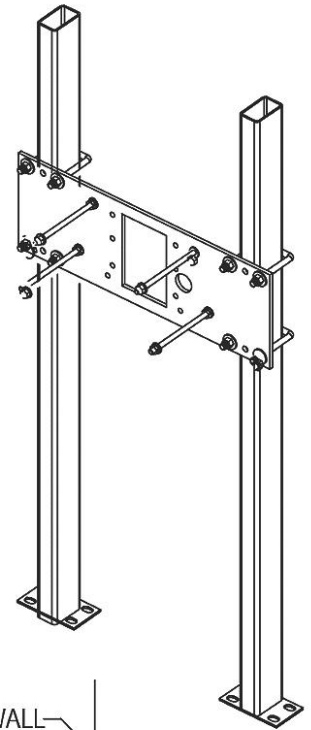

**WITH STANDARD STUD LENGTH OF 6 INCHES

In comparing with other products, be certain these features are not overlooked. For the most current version of Elkay product specification sheets. This specification describes an Elkay product with design, quality, and functional benefits to the user. When making a comparison of other producers' offerings, be certain these features are not overlooked.

In keeping with our policy of continuing product improvement, Elkay reserves the right to change product specifications without notice. Please visit elkay.com for the most current version of Elkay product specification sheets. This specification describes an Elkay product with design, quality, and functional benefits to the user. When making a comparison of other producers' offerings, be certain these features are not overlooked.