

PRODUCT SPECIFICATIONS

Elkay Soft Sides® Single Composite Fountain Non-Filtered, Non-Refrigerated Freeze Resistant White Granite Composite. Features shall include Freeze Resistant. Furnished with Vandal Resistant bubbler. Mechanical Front Bubbler Button activation. Product shall be Wall Mount (On Wall), for Indoor + Outdoor applications, serving 1 station(s). Unit shall be lead-free design which is certified to NSF/ANSI 61 & 372 (lead free) and meets Federal and State low-lead requirements.

Special Features:	Freeze Resistant
Finish:	White Granite Composite (WHT)
Power:	No Electrical Required
Bubbler Style:	Vandal Resistant
Activation by:	Mechanical Front Bubbler Button
Mounting Type:	Wall Mount (On Wall)
Chilling Option:	Non-refrigerated
Dimensions (L x W x H):	13-11/16" x 18-3/16" x 7-1/8"
Approx. Shipping Weight:	56 lbs.
Installation Location:	Indoor + Outdoor
No. of Stations Served:	1

- Mechanically-Activated bubbler continues to supply water in event of service disruptions.
- With a contemporary look and smooth, rounded lines, these wall mounted drinking fountains are constructed of a premium composite, solid surface material.
- Freeze Resistant:
 - Depending on specific installation, freeze resistant system is located either below frost line or in temperature controlled space.



White (WHT)

AMERICAN PRIDE. A LIFETIME TRADITION.
Like your family, the Elkay family has values and traditions that endure. For almost a century, Elkay has been a family-owned and operated company, providing thousands of jobs that support our families and communities.



Included with Product: Fountain, Freeze Resistant Valve Assembly

▼ Ships in multiple boxes.

PRODUCT COMPLIANCE

ADA & ICC A117.1
Buy American Act
NSF/ANSI 61 & 372 (lead free)



Complies with ADA & ICC A117.1 accessibility requirements when installed according to the requirements outlined in these standards. Installation may require additional components and/or construction features to be fully compliant. Consult the local Authority Having Jurisdiction if necessary.

[Installation Instructions \(PDF\) - 98428C](#)
[Installation Instructions \(PDF\) - 97566C](#)

Water Systems are warranted for 12 months from date of installation. **Warranty pertains to drinking water applications only. Non-drinking water applications are not covered under warranty.**

[Warranty \(PDF\)](#)

OPTIONAL ACCESSORIES

MPW101 - Accessory - In Wall Carrier (Single) for EDFP210, EDFP214, EDFPB114, EDFPBW114, EHW214 models
WP2 - Accessory - Wall Plate for EDFP210C and EDFP214C fountains
EW172 - WaterSentry VII Filter Kit (Coolers + Fountains)

PART: _____ QTY: _____

PROJECT: _____

CONTACT: _____

DATE: _____

NOTES: _____

APPROVAL: _____

In keeping with our policy of continuing product improvement, Elkay reserves the right to change product specifications without notice. Please visit elkay.com for the most current version of Elkay product specification sheets. This specification describes an Elkay product with design, quality, and functional benefits to the user. When making a comparison of other producers' offerings, be certain these features are not overlooked.

INSTALLER NOTE

This drinking fountain is furnished with a bubbler and valve including all connecting fittings which are manufactured of completely lead free material. Shut off valve (not furnished) to accept 3/8" O.D. unplated copper tube.

OPERATION OF QUICK CONNECT FITTINGS

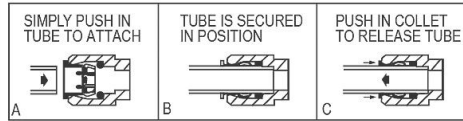

PUSHING TUBE IN BEFORE PULLING IT OUT HELPS TO RELEASE TUBE

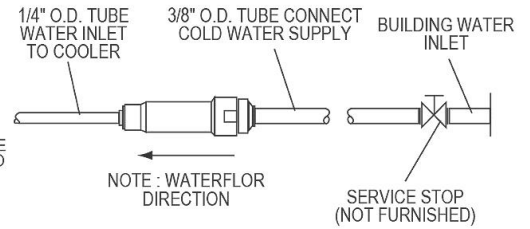

Care and Maintenance of Elkay Composite Fountains

The premium composite fountain provides an extremely durable, non-porous surface with resists staining. Care is very simple. Routine cleaning with a soft sponge or cloth, or with water or non-abrasive aerosol foam cleaner, is all that is normally needed to give many years of trouble free service. Cleaners left standing on the fountain surface can dull the surface finish. Be certain to rinse all cleaning agents completely and polish with a soft cloth.

Harsh abrasive cleaners are not required and should not be used.

Mild abrasives such as liquid automotive cleaning compound or baking soda paste will remove simple scratches and stains. Cigarette burns can normally be removed without noticeable effect. Deeper scratcher or gouges can be corrected with fine grit sandpaper (240 grit then 400 grit) or a green scotchbrite™ pad.

To maintain or regain luster and make cleaning easier, periodic applications of automobile wax or like products will keep the finish looking like new.

WARNING: The free-resistant box must be installed on an interior heated wall where the temperature does not drop below 50° F (10° C). The front of the box must have unobstructed air flow. Failure to maintain the interior wall temperature and the inside of the freeze resistant box above 50° F (10° C) can result in damage to the box which could result in unrestricted water flow.

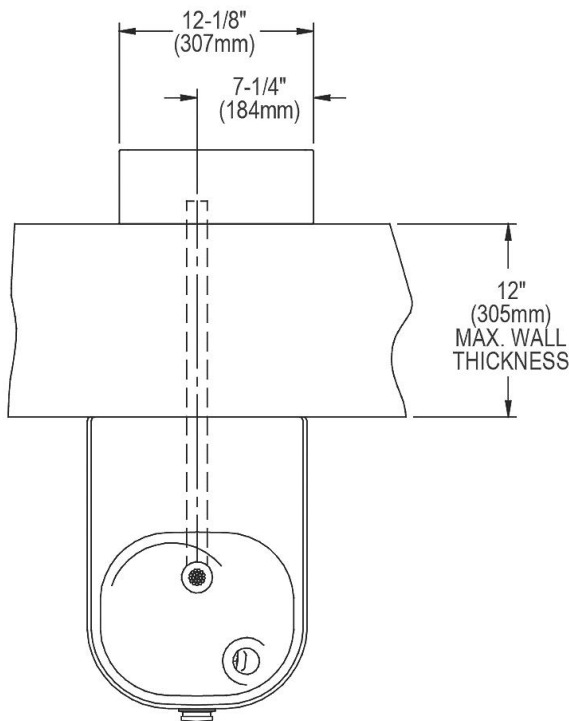

LEGEND:

- A = Recommended water supply location 3/8" O.D. unplated copper tube connect
- B = Recommended location for waste outlet 1-1/4" O.D. drain
- C = Recommended location for operating cable 7/8" diameter hole
- D = Mounting holes for securing fountain to wall (blocking & wall support is required in these areas for proper support of fountains)

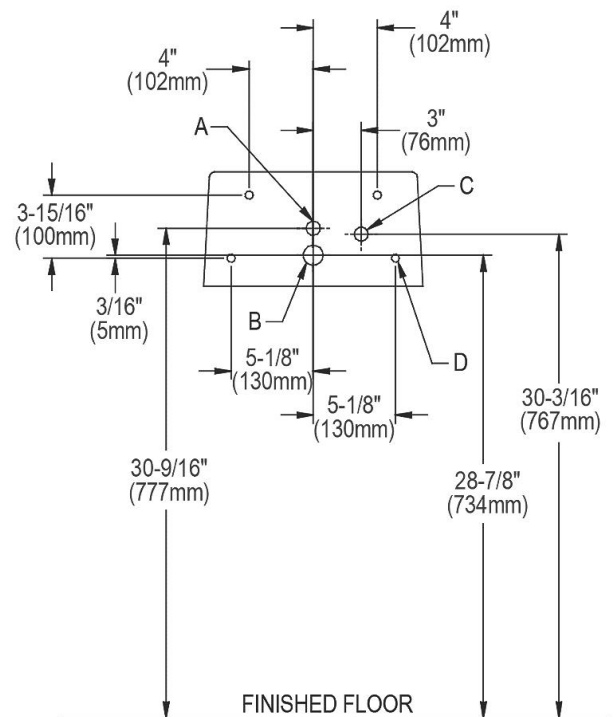

In keeping with our policy of continuing product improvement, Elkay reserves the right to change product specifications without notice. Please visit elkay.com for the most current version of Elkay product specification sheets. This specification describes an Elkay product with design, quality, and functional benefits to the user. When making a comparison of other producers' offerings, be certain these features are not overlooked.