

**PRODUCT SPECIFICATIONS**

Elkay Lustertone™ Classic Stainless Steel 41" x 19-1/2" x 7-5/8", Double Bowl Drop-in Classroom Sink. Sink is manufactured from 18 gauge 304 Stainless Steel with a Lustrous Satin finish, Center drain placement, and Sides and Bottom pads.

<b>Installation Type:</b>	Drop-in
<b>Material:</b>	304 Stainless Steel
<b>Finish:</b>	Lustrous Satin
<b>Gauge:</b>	18
<b>Sound Deadening:</b>	Sides and Bottom pads
<b>Number of Bowls:</b>	2
<b>Sink Dimensions:</b>	41" x 19-1/2" x 7-5/8"
<b>Bowl 1 Dimensions:</b>	19" x 16" x 7-1/2"
<b>Bowl 2 Dimensions:</b>	10" x 14" x 3-1/2"
<b>Drain Size:</b>	3-1/2" (89mm), 2" (51mm)
<b>Drain Location:</b>	Center
<b>Minimum Cabinet Size:</b>	45"
<b>Mounting Hardware:</b>	Part # 64090008 included for countertops up to 3/4" (19mm) thick



**AMERICAN PRIDE. A LIFETIME TRADITION.**  
Like your family, the Elkay family has values and traditions that endure. For almost a century, Elkay has been a family-owned and operated company, providing thousands of jobs that support our families and communities.



**Product Compliance:** ASME A112.19.3/CSA B45.4  
BUY AMERICAN ACT

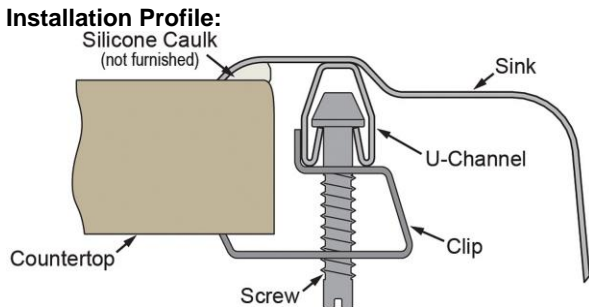

**OPTIONAL ACCESSORIES**

<b>Hardware:</b>	LK364, LK463 (2 Required)
<b>Sinkmate:</b>	LKSMHSL

Sinks are listed by IAPMO® as meeting the applicable requirements of the Uniform Plumbing Code®, International Plumbing Code®, and National Plumbing Code of Canada.

- [Clean and Care Manual \(PDF\)](#)
- [Installation Instructions \(PDF\)](#)
- [Limited Lifetime Warranty \(PDF\)](#)

Three Faucet Holes 1-1/2" (38mm) Diameter Faucet Holes on 4" (102mm) Centers  
One Slotted Hole 1-1/8" (29mm) Diameter Slotted Hole

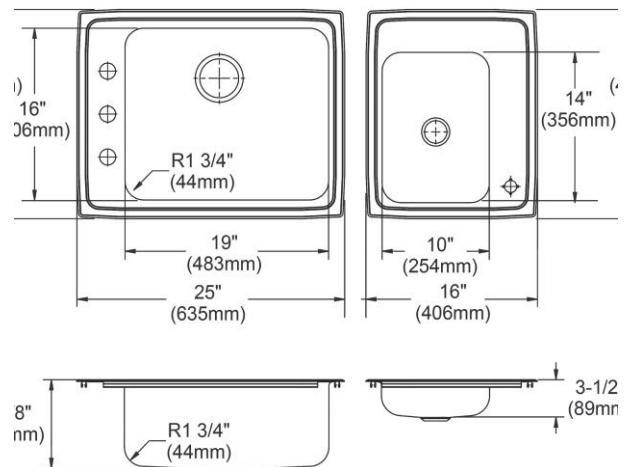

PART: \_\_\_\_\_ QTY: \_\_\_\_\_  
 PROJECT: \_\_\_\_\_  
 CONTACT: \_\_\_\_\_  
 DATE: \_\_\_\_\_  
 NOTES: \_\_\_\_\_  
 APPROVAL: \_\_\_\_\_

*In keeping with our policy of continuing product improvement, Elkay reserves the right to change product specifications without notice. Please visit [elkay.com](http://elkay.com) for the most current version of Elkay product specification sheets. This specification describes an Elkay product with design, quality, and functional benefits to the user. When making a comparison of other producers' offerings, be certain these features are not overlooked.*