

Halsey Taylor®

Universal Vandal Resistant Kit 98030C Service Manual

This kit contains a sufficient quantity of tamper-resistant screws to modify your water cooler.

Kit consists of:

PAGE NO.	TABLE OF CONTENTS
1	HCRF, WC8A, HAC, HTE & HRFE Models
2	SCWT, WM8A & SW8A Models
3	OVL-E Model & Std. to VR Bubbler replacement instructions for all HALSEY TAYLOR product
4	HTV model

PARTS LIST			
ITEM NO.	QTY.	PART NO.	DESCRIPTION
1	1	75520C	Bit - Pinned Torx T-25
2	1	75523C	Bit - Pinned Torx T-20
3	18	75570C	Screw - #10 X .50" Pinned Torx
4	10	75661C	Screw - #8 X .50" Pinned Torx
5	1	15009C	Bubbler Nipple
6	1	45866C	VR Bubbler
7	2	75664C	Locking Washer
8	2	75566C	Screw - #10 X 1" Pinned Torx

HCRF, HTE & HRFE model modification instructions:

1. Remove bottom cover screws one at a time and replace with a tamper-resistant screw of the same size and length. Special drive bits are provided for the tamper resistant screws.

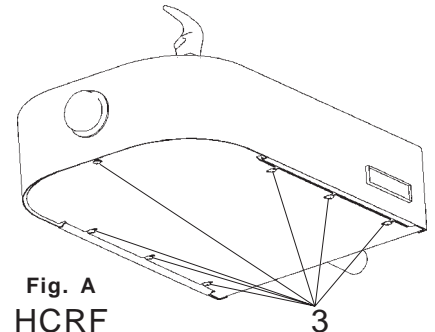

Fig. A
HCRF
Shown

CAUTION: DO NOT REMOVE ALL EXTERIOR SCREWS BEFORE REPLACING THEM WITH TAMPER-RESISTANT SCREWS.

HAC & WC8A model modification instructions:

1. Remove exterior screws one at a time and replace with a tamper-resistant screw of the same size and length. Special drive bits are provided for the tamper resistant screws.

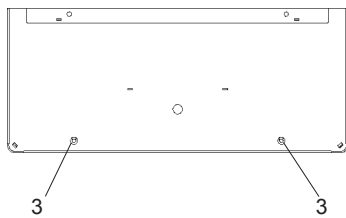

Fig. B
HAC

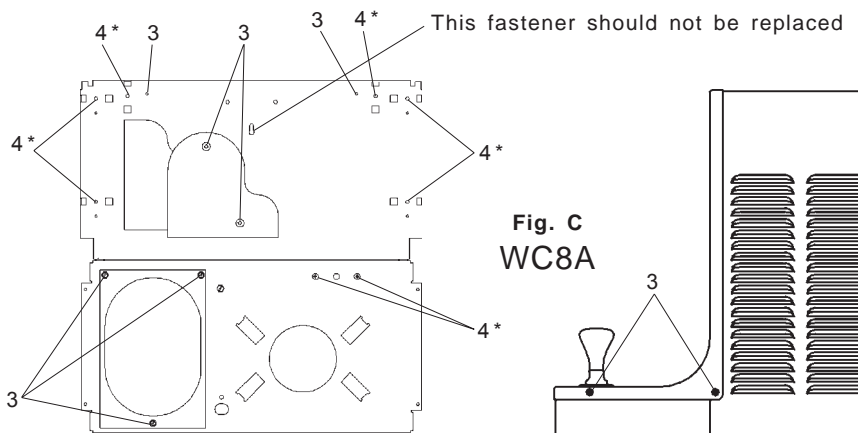

Fig. C
WC8A

* When disassembling the hinge pivot points on this unit, replace the vandal resistant screw immediately. Be certain that the pivot block remains fully seated in place when replacing the vandal resistant screw.

PRINTED IN U.S.A.

FOR PARTS CONTACT YOUR LOCAL DISTRIBUTOR OR VISIT OUR WEBSITE - WWW.HALSEYTAYLOR.COM

WM8A & SW8A model modification instructions:

1. Remove exterior screws one at a time and replace with a tamper-resistant screw of the same size and length. Special drive bits are provided for the tamper resistant screws.

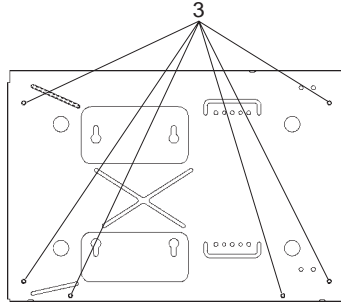
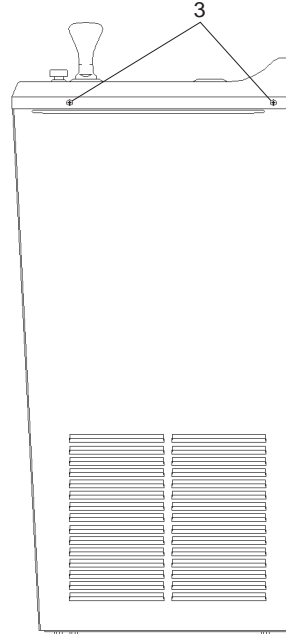

Fig. D
WM8A
Shown



SCWT model modification instructions:

1. Remove exterior screws one at a time and replace with a tamper-resistant screw of the same size and length. Special drive bits are provided for the tamper resistant screws.

Fig. E
SCWT

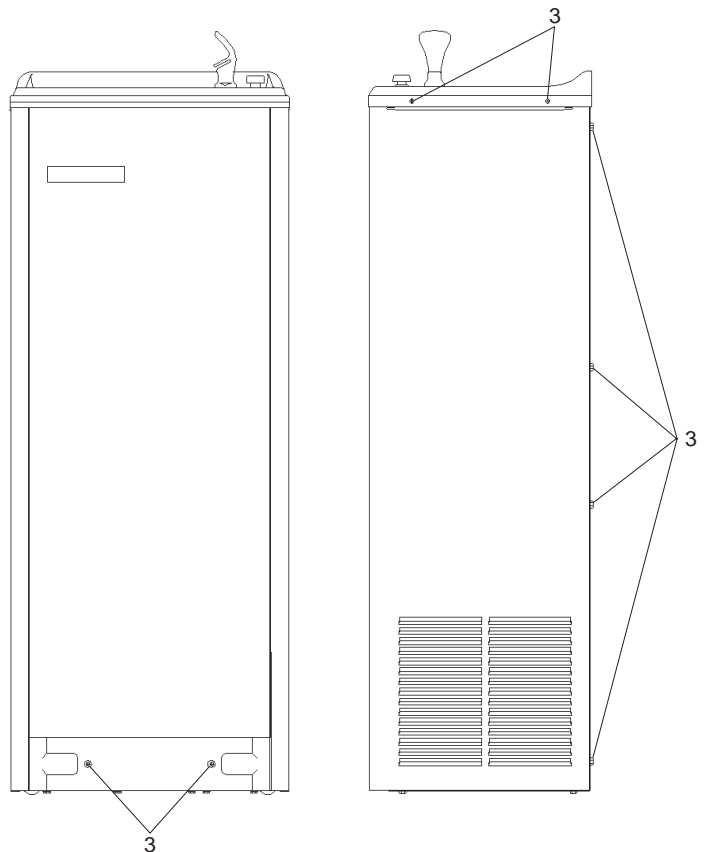

FOR PARTS CONTACT YOUR LOCAL DISTRIBUTOR OR VISIT OUR WEBSITE - WWW.HALSEYTAYLOR.COM

Fig. F
OVL-E

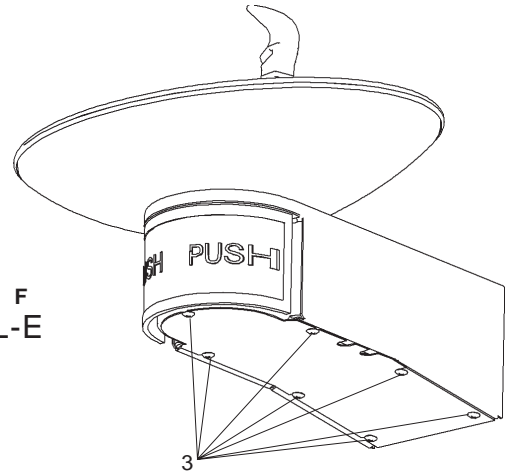

OVL - E model modification instructions:

1. Remove bottom cover screws one at a time and replace with a tamper-resistant screw of the same size and length. Special drive bits are provided for the tamper resistant screws.

Instructions for switching from **Standard Bubbler** to **VR Bubbler**
for all *Halsey Taylor* Product:

Fig. G
VR Bubbler

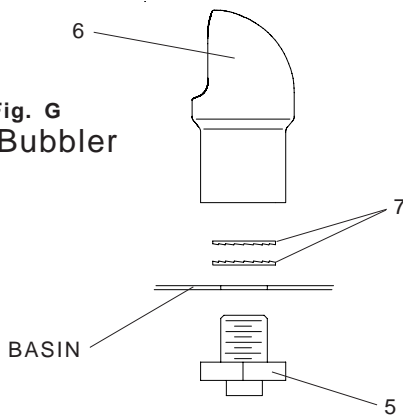

1. Remove fountain or cooler panel to gain access to the bubbler fitting from underneath the basin. (We recommend that the bubbler on OVL units should not be replaced due to the difficulty of disassembling the basin components.)
2. Remove existing bubbler from the unit. Hold the bubbler fitting on the underside of the basin and unscrew bubbler from the top of the basin.
3. If the bubbler nipple is plastic, replace with the new metal bubbler nipple (Item 5) by removing the tube from the quick connect fitting (See Figure H) and reinserting the tube approximately 3/4" in the metal nipple.
4. Remove and discard the sealing gaskets (black rubber washers) from above and below the basin. Reinsert the bubbler fitting into the basin.
5. Assemble the two lockwashers (Item 7) to the bubbler fitting. See figure G.
6. Apply thread sealer (not provided) to the bubbler fitting threads.
7. Assemble the bubbler to the bubbler fitting and tighten the bubbler fitting. The bubbler should be one quarter turn less than the desired position when the bubbler fitting is securely tightened from the underside of the basin.
8. For proper function of the lockwashers, the bubbler must be turned the last quarter turn from the upper side of the basin. This assembly method seats the lockwashers properly for correct operation.
9. Operate the unit and check for leaks.
10. Reassemble the fountain or cooler panel as required.

HTV model modification instructions:

To switch to vandal resistant screws:

1. Replace bottom cover screws with the two vandal resistant screws (Item 8) as shown in Figure J.

To switch to vandal resistant bubbler:

1. Remove cooler panels to gain access to the bubbler nipple under the basin.
2. Remove the existing bubbler by holding the bubbler nipple and unscrewing the bubbler.
3. If the bubbler nipple is plastic, replace with the new metal bubbler nipple (Item 5) by removing the tube from the quick connect fitting (see Figure J - Page 4) and reinserting the tube approximately 3/4" in the metal nipple.
4. Discard the two black rubber bubbler gaskets and reinsert the bubbler nipple through the basin hole.
5. Assemble the two lockwashers (Item 7) to the bubbler nipple (see Figure G - Page 3).
6. Apply thread sealer (not provided) to the bubbler nipple threads.
7. Assemble the bubbler to the bubbler nipple and tighten the bubbler nipple. The bubbler should be one quarter turn less than desired position when the bubbler fitting is securely tightened from the underside of the basin.
8. For proper function of the lockwashers, the bubbler must be turned the last a quarter turn from the top side of the basin. This assembly method seats the lockwashers properly to prevent easy removal.
9. Operate the cooler to check for water leaks.

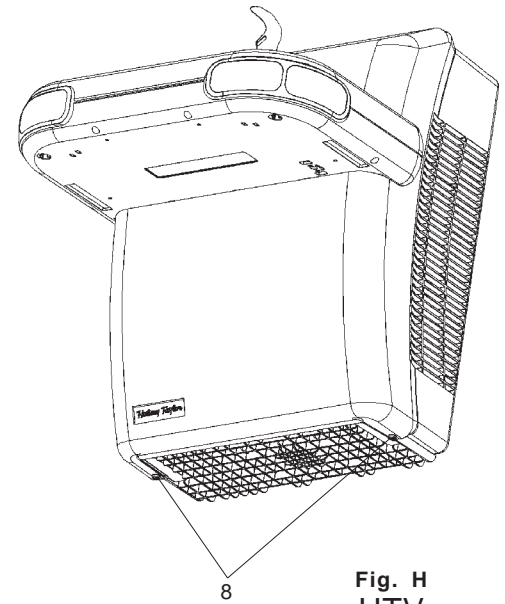

Fig. H
HTV

Fig. J
OPERATION OF QUICK CONNECT FITTINGS

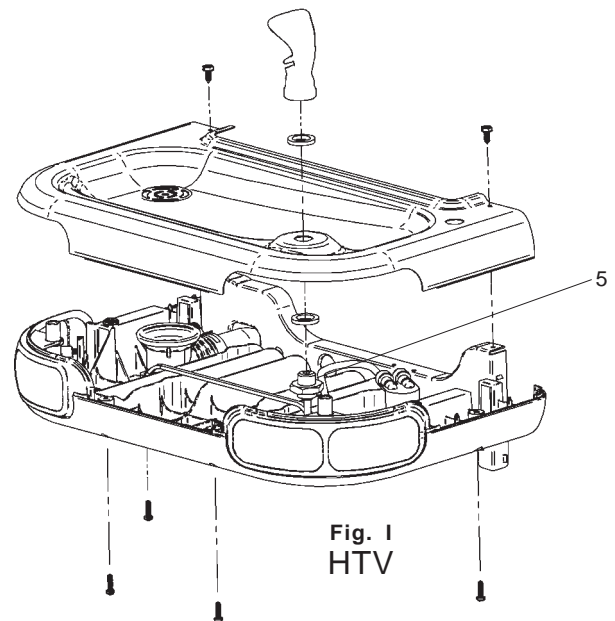
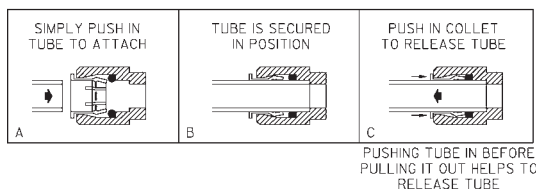

Fig. I
HTV

Halsey Taylor®

2222 CAMDEN COURT
OAK BROOK, IL 60523
630.574.3500

FOR PARTS CONTACT YOUR LOCAL DISTRIBUTOR OR VISIT OUR WEBSITE - WWW.HALSEYTAYLOR.COM