

Halsey Taylor Owners Manual

Model : 97056C

Frost Resistant Package

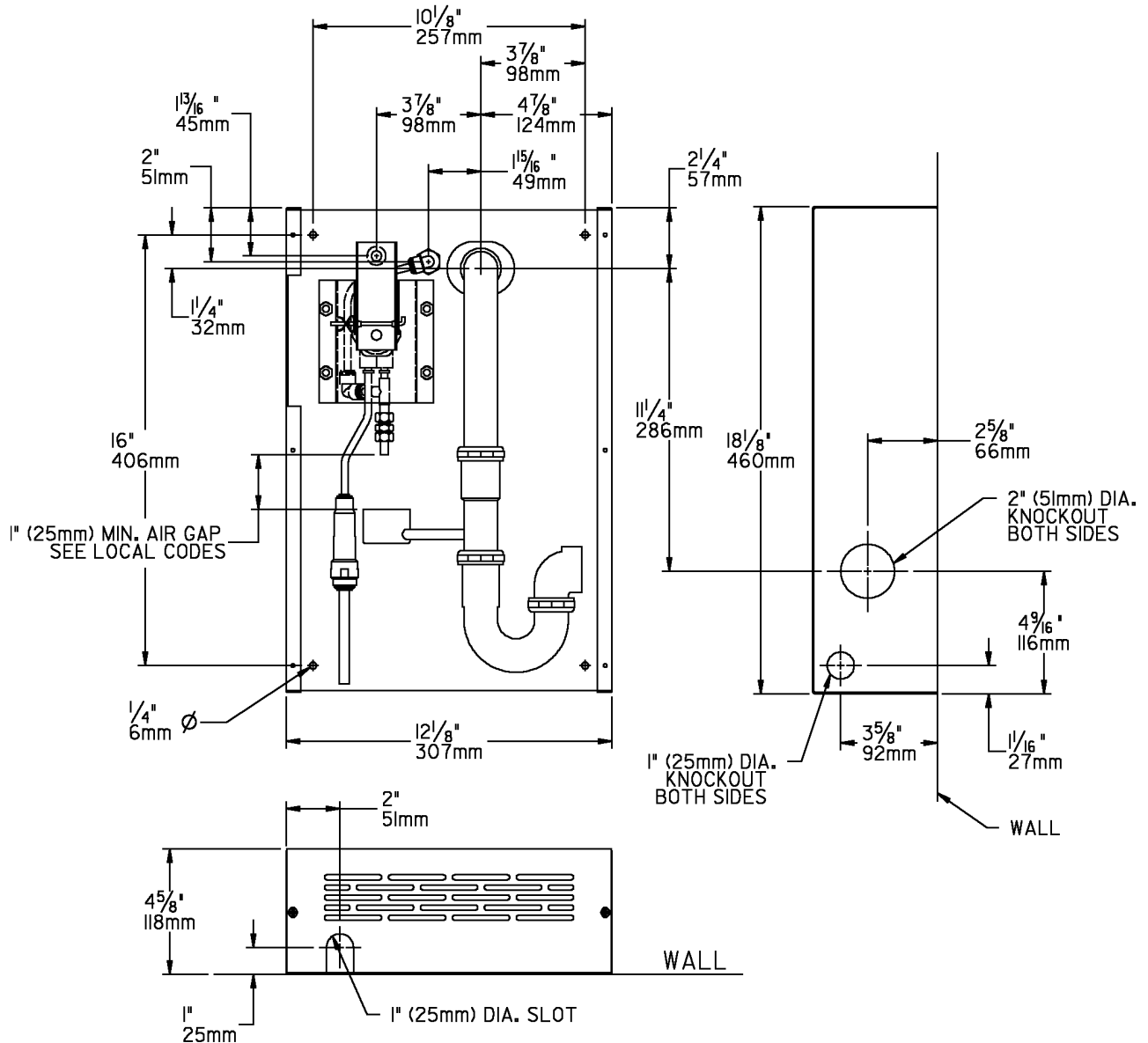
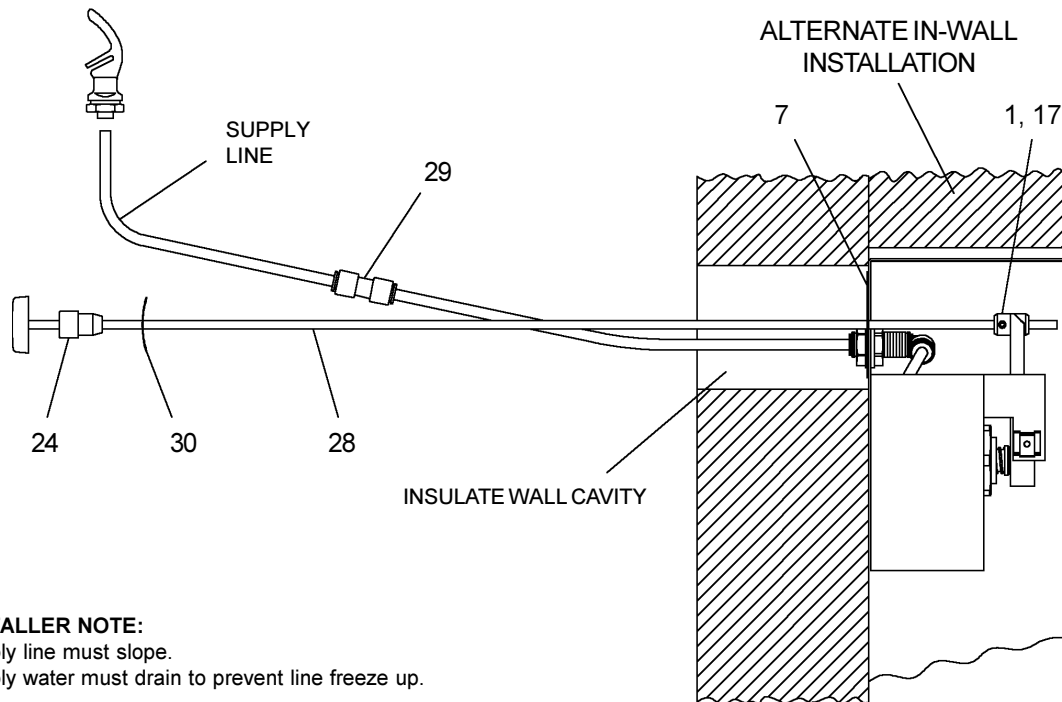

FIG. 1

WARNING: This Frost Resistant Package must be installed on an interior heated wall. The front of the box must have unobstructed air flow. Failure to maintain the interior wall temperature and the inside of the Frost Resistant Package at an above freezing temperature can and will cause damage to the Frost Resistant Package. This damage can result in bursting and rupturing of interior plumbing which will result in uncontrollable water flow and flooding of the area. Rough-In dimensions will vary depending upon the type of fountain that this package is installed with. Dimensions shown are for reference only.



INSTALLER NOTE:
 Supply line must slope.
 Supply water must drain to prevent line freeze up.

FIG. 2

INSTALLATION

The frost resistant package may be surface mounted or recessed on an interior wall in a heated area. If recessed, the surface of the cover (Item 6) **MUST** be flush with the interior wall surface (not recessed). The box is furnished with screws for mounting the cover to the box. **DO NOT** fasten the top and bottom of the cover to the box if it is to be recessed in an interior wall. Use the holes on the front only in this application.

1. Assemble the push button to the fountain body - see fountain instructions.
2. Install the fountain body in accordance with the fountain installation instructions and connect waste tube.
NOTE: Waste arm furnished. It will accommodate a wall thickness up to 12" (65mm).
3. Insulate the wall cavity between the freeze resistant box and the fountain. The push rod **MUST** be free to move.
4. Insert 1/4 inch tube and union into outlet of box.
5. Install washer (Item 7) and one (1) push button stop (Item 1) and one (1) set screw (Item 17) onto the push rod. Locate the box on the wall over the drain and push rod and attach to wall using screws (not provided).
6. With the rod in the full "off" position, tighten the stop against the activating lever by tightening set screw. Install the second stop and set screw on the opposite side of the activating lever and tighten.
7. Connect the water line to the fountain and ensure that push rod is free to move.

START UP

1. Turn on the building water supply and check all connections for leaks.
2. Stream height is factory set at 35 PSI. If supply pressure varies greatly from this, adjust screw on item 14. Clockwise adjustment will raise the stream and counter-clockwise adjustment will lower it. For best adjustment, stream height should be approximately 1-1/2" above the bubbler guard.
3. Recheck all water and drain connections with water flowing through system.
4. Put cover on box.

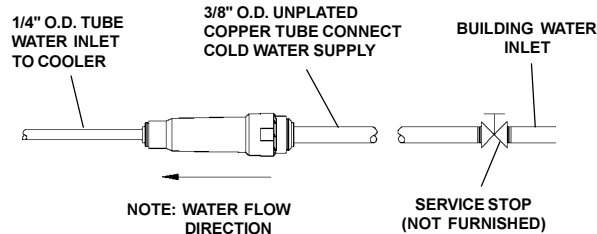

FIG. 3

OPERATION OF QUICK CONNECT FITTINGS

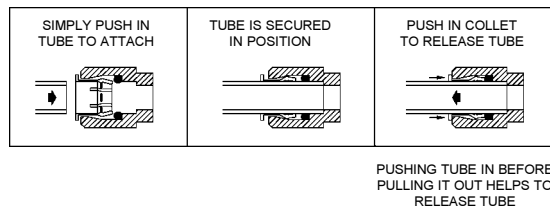

FIG. 4

PARTS LIST		
ITEM NO.	PART NO.	DESCRIPTION
1	10003C	STOP-PUSH BUTTON
2	10031C	NUT-RETAINING
3	27051C	CHANNEL-PIVOT
4	27052C	CHANNELASSY VALVE MTG
5	27310C	BODY ASSY
6	27312C	COVER-BODY
7	27313C	WASHER-PUSH ROD
8	31525003	O RING-.375X.239X.070
9	40045C	NUT HEX-UNPLTD
10	40266C	VALVE-CHECK
11	40267C	INSERT-.25 DIA CU
12	50198C	BUSHING-SNAP
13	50985C	HOLDER-REGULATOR
14	61313C	REGULATOR - W/RED SPRING
15	62091C	WATER OUTLET ASSY
16	66454C	DRAIN TUBE ASSEMBLY
17	70021C	SCREW-SET 8-32X.25
18	70284C	BODY-CHECK VALVE
19	55996C	STRAINER
20	70793C	ELBOW 1/4OD X 90
21	70817C	ELBOW-1/4 STEM-1/4 TUBE
22	70831C	ROD-SUPPORT
23	70841C	UNION-BULKHEAD
24	50003C	BUSHING-SNAP
25	72000835	1-1/4IN SINK TRAP
26	72001843	SLIP ELL 22GA 1 1/4 X 7
27	75555C	CLIP - 125 STUD LOCK
28	55000458	PUSH BUTTON ASSY
29	70683C	UNION-1/4
30	70054C	NUT-SPEED
NS	AS2157	5/64 ALLEN WRENCH

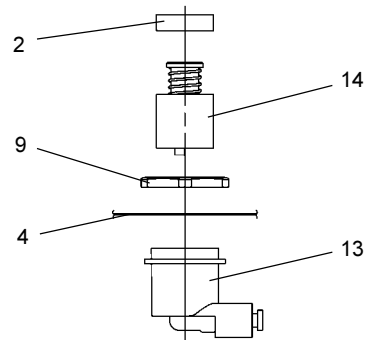

FIG. 5

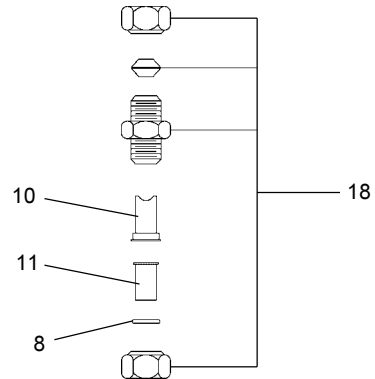
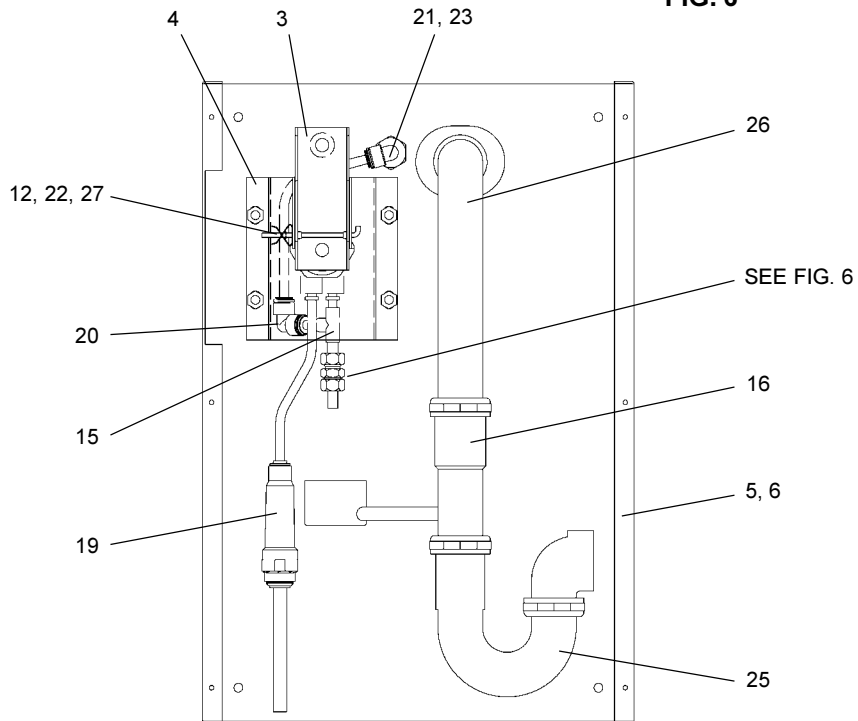

FIG. 6



TROUBLE SHOOTING AND MAINTENANCE

Actuation of Quick Connect Water Fittings: Frost resistant box is provided with lead-free connectors which utilize an o-ring water seal. To remove tubing from the fittings, relieve water pressure, push in on gray collar while pulling on the tubing (See Fig. 4). To insert tubing, push tube straight into fitting until it reaches a positive stop, approximately 3/4".

Halsey Taylor®

2222 CAMDEN COURT
OAK BROOK, IL 60523
630.574.3500

PRINTED IN U.S.A.

FOR PARTS, CONTACT YOUR LOCAL DISTRIBUTOR OR CALL 1.800.323.0620