







C.1





Instructions for mounting and use	Thermostatic shower and bath mixer for concealed installation
Notice de montage et d'utilisation	Mitigeur thermostatique de douche et baignoire encastré
Instrucciones de montaje y uso	Termostato de teleducha y bañera empotrado

	Important information	4
	Installation	5
	Operation	10
	Care & maintenance	15

en

	Remarques importantes	17
	Montage	18
	Commande	23
	Entretien & maintenance	28

fr

	Información importante	30
	Montaje	31
	Manejo	36
	Conservación y mantenimiento	41

es



These instructions are part of the Duravit product and must be read carefully and kept available at all times.

Target readership and qualifications

The product may only be installed by a qualified plumber.

Explanation of the key words



Indicates a hazardous situation which, if not avoided, could result in minor or moderate injury.

NOTICE

Addresses practices not related to physical injury.

Technical data

Operating pressure	max. 72.5 PSI
Recommended	43.5 PSI
Test pressure	72.5 PSI
1 MPa = 10 bar = 145 PSI	
Hot water temperature	max. 140 °F

For use with showerheads rated at 6.1 l/min (1.6 gpm) or higher.



This unit meets or exceeds the following:

- ASME A112.18.1
- CSA B125.1
- ADA Compliant

Safety instructions

Cut and crush injuries

- > Wear gloves when installing the product.

Product and/or property damage

- > Observe the local installation regulations and any country-specific standards at all times.
- > Equalise pressure differences between cold and hot water connections.
- > Observe the manufacturer's instructions for installation with continuous flow heaters.

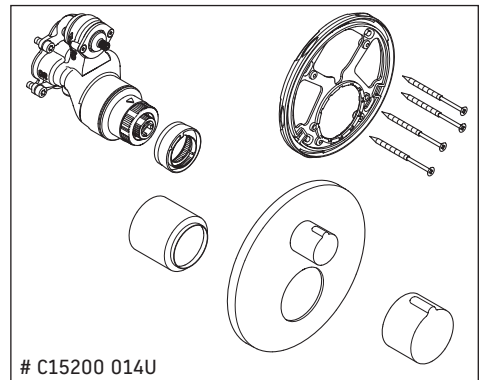
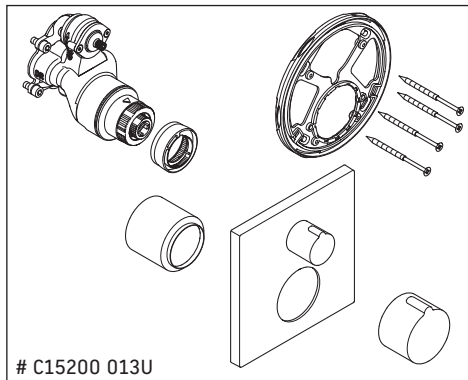
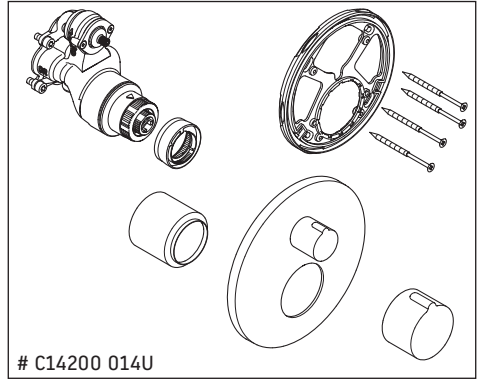
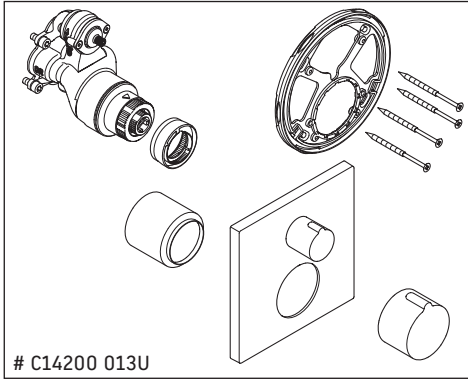



en

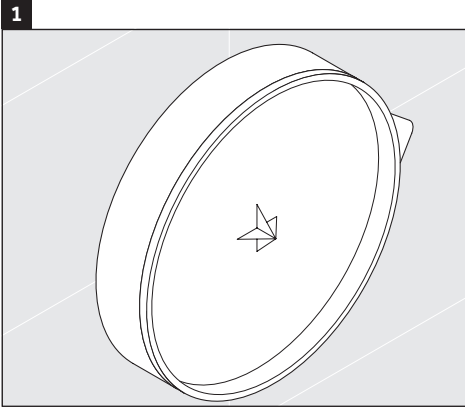

> Remove the dust cover.

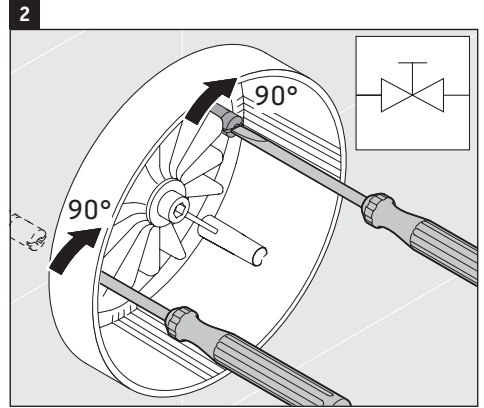

> Close the hot and cold stops.

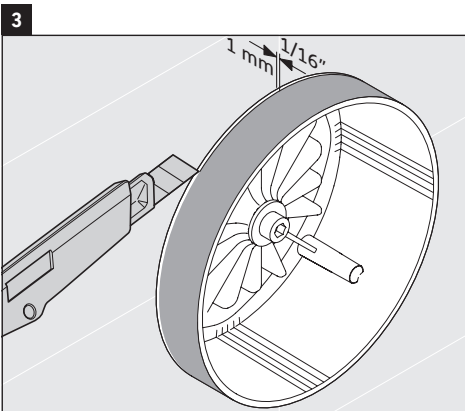

> Cut the plaster shield so it extends 1/16" from the finished wall surface.

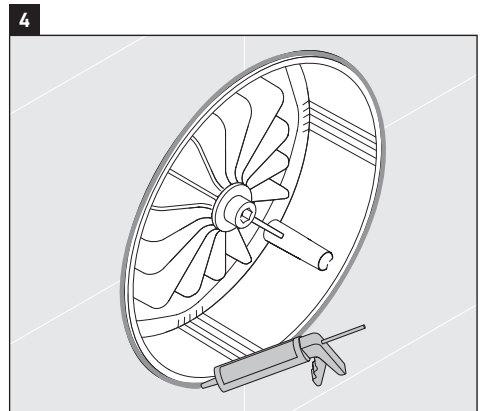

NOTICE

Water damage

> Seal the wall around the plaster shield with silicone without acetic acid.



5

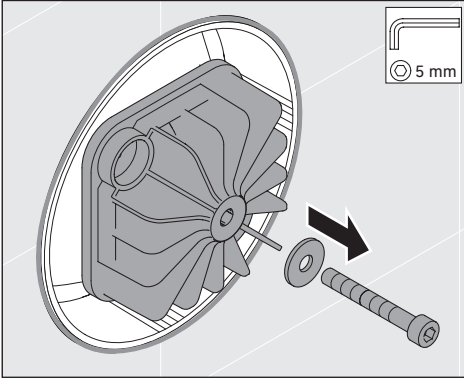

> Remove the rough insert and the rough insert seals.

6

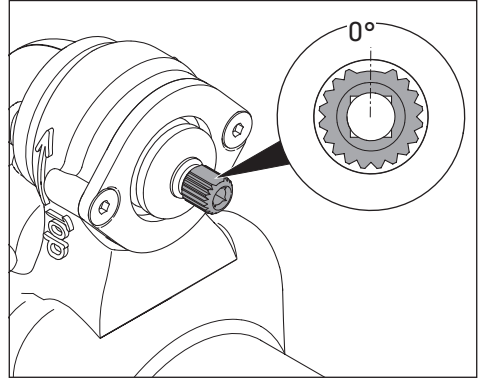

> Set the valve pin 0°.

en

7

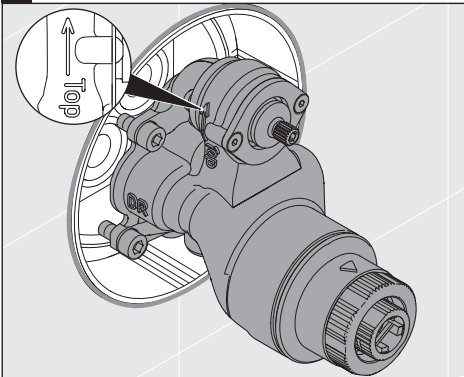

> Install the functional unit.

8

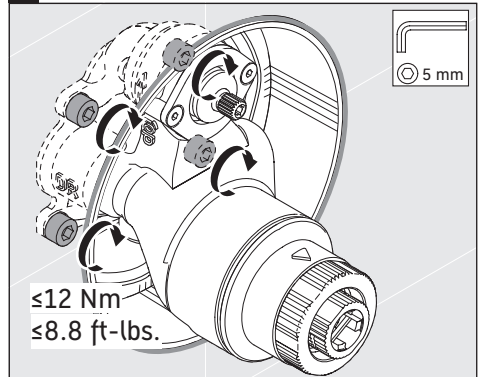

> Install and tighten functional unit screws. Not to exceed 8.8 ft-lbs.



en

9

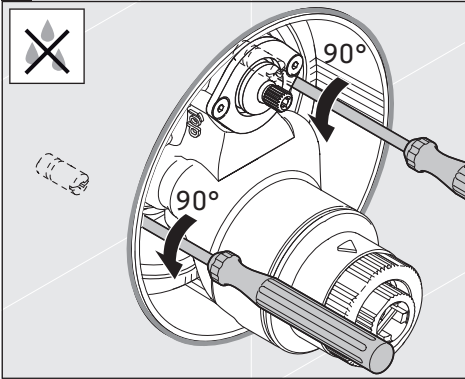

- > Open the stops.
- > Check for leaks.

10

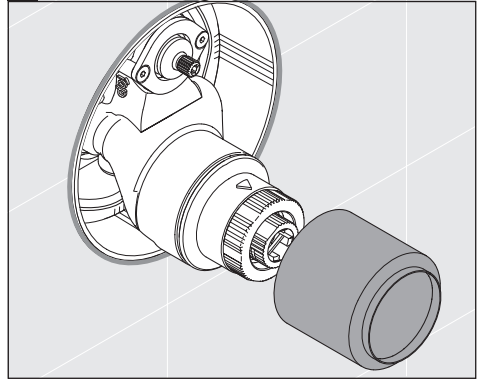

- > Slide on the thermostatic mixer sleeve.

11

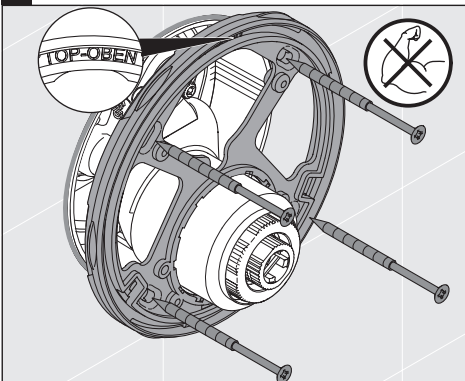

- > Install the escutcheon frame.

12

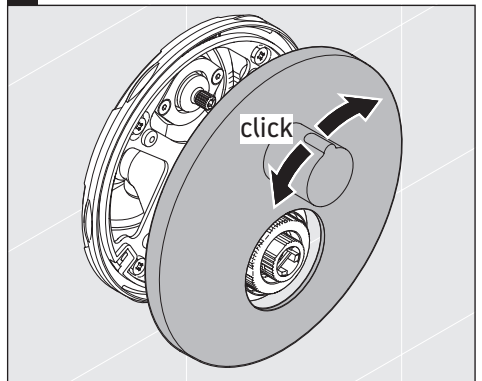

- > Install the escutcheon.



13

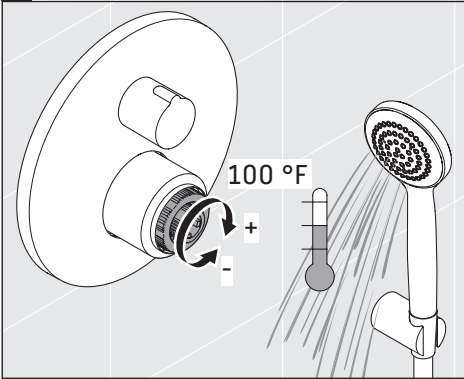

14

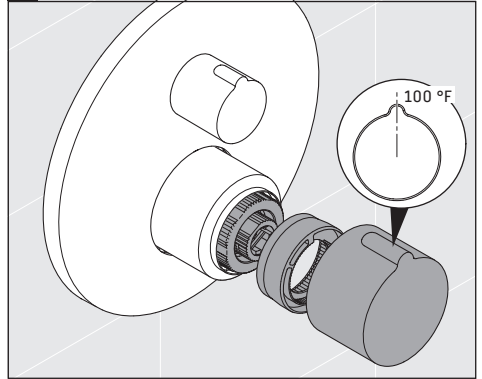

en

CAUTION Hot water can cause scalding

- > Set the high limit temperature limit stop.
- > Follow all applicable local plumbing codes when setting high temperature limit stop.

NOTICE

To prevent scald injury, the maximum output temperature of the shower valve must be no higher than 120 °F.

In Massachussets the maximum output temperature can be no higher than 112 °F.

> Install the handle.



C14200 013U, # C14200 014U

en

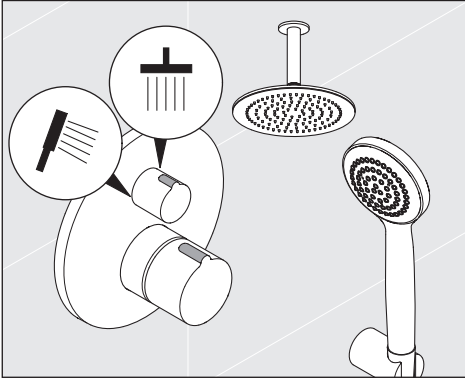

> Turn on the overhead and the handheld shower.

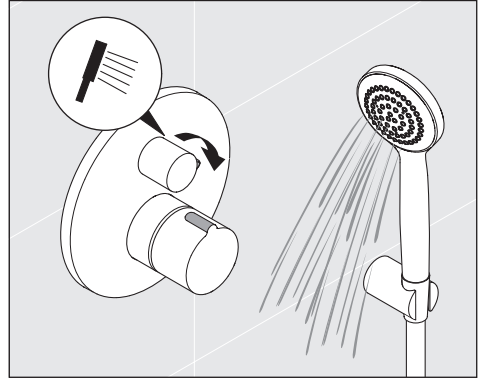

> Turn the diverter handle to the right to turn on the overhead shower.

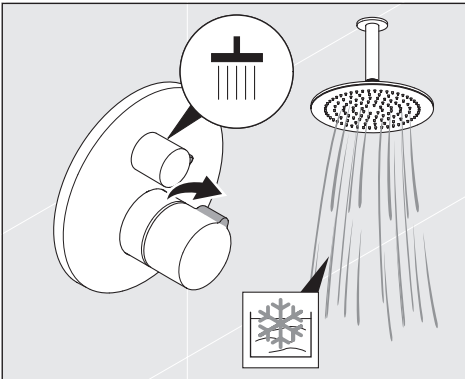

> Check the overhead shower for cold water.

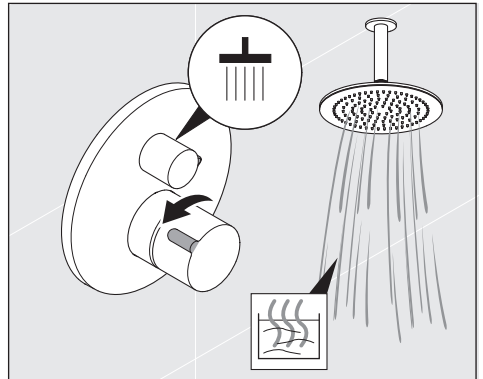

> Check the overhead shower for hot water.

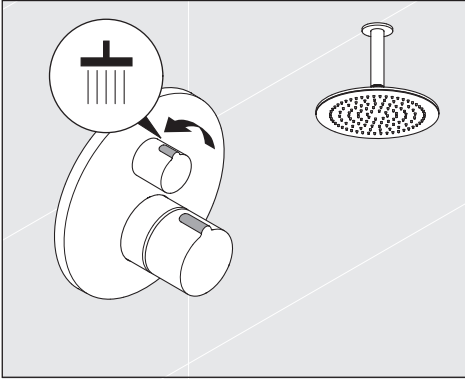

> Turn off the overhead shower.

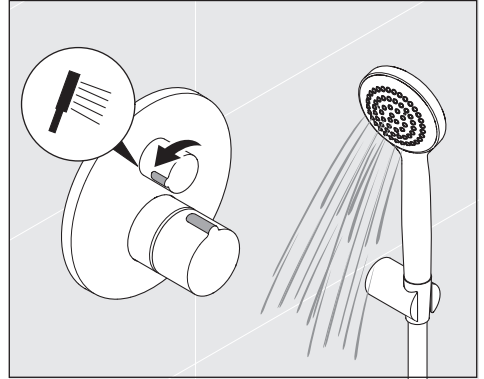

> Turn the diverter handle to the left to turn on the handheld shower.

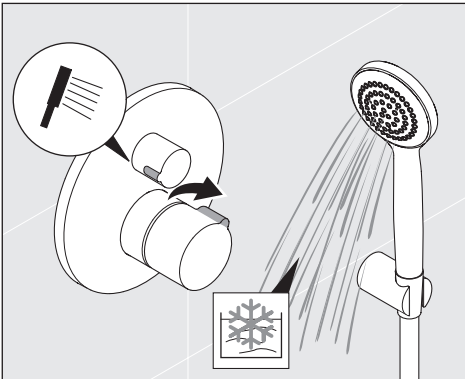

> Check the handheld shower for cold water

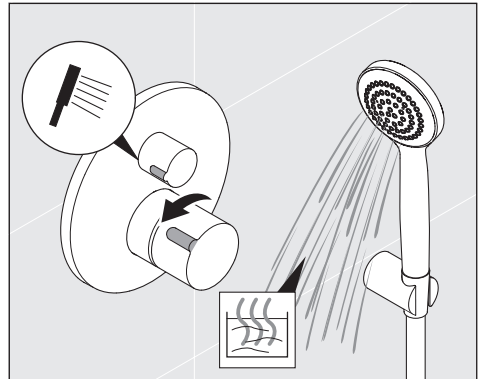

> Check the handheld shower for hot water.



en

C15200 013U, # C15200 014U

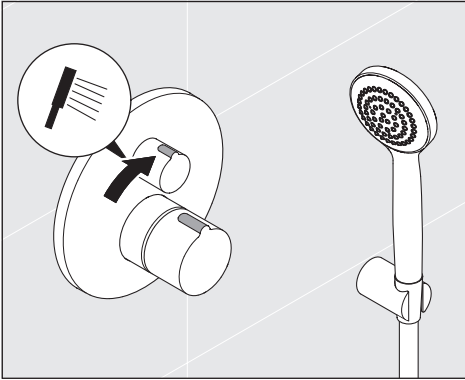

> Turn off the handheld shower.

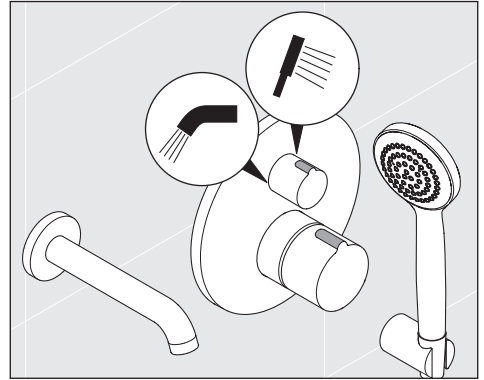

> Control can be used for either shower head or spout.

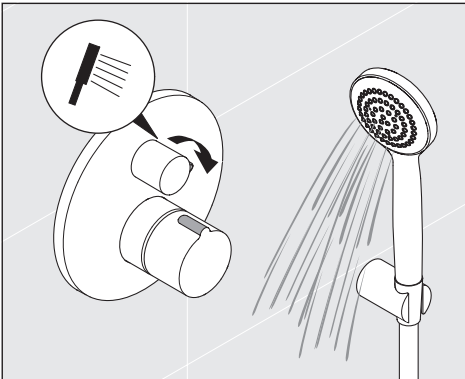

> Turn the diverter handle to the right to turn on the handheld shower.

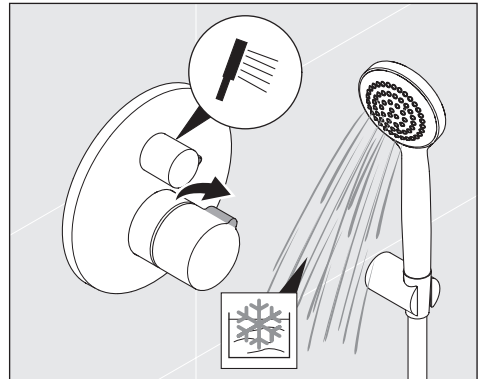

> Check the handheld shower for cold water.

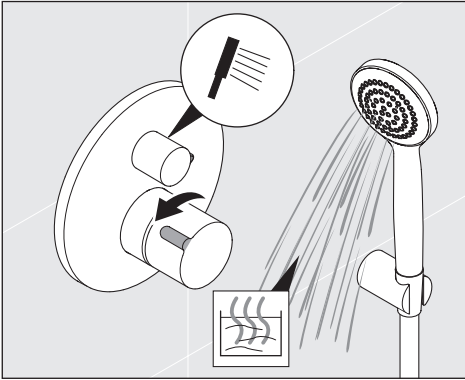

> Check the handheld shower for hot water.

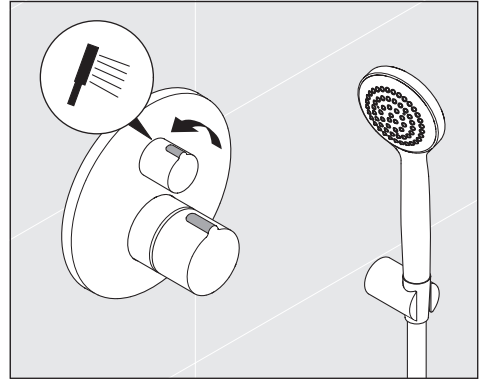

> Turn off the handheld shower.

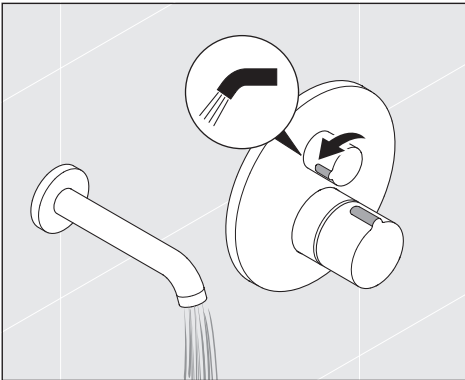

> Turn the diverter handle to the left to turn on the spout.

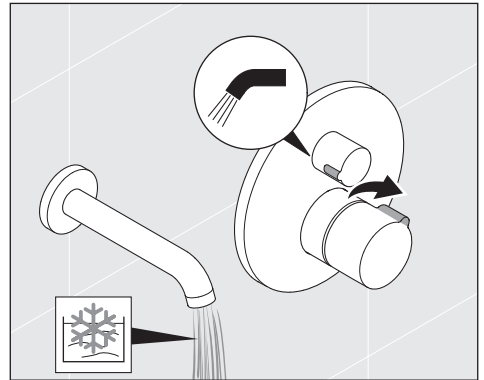

> Check the spout for the cold water.



en

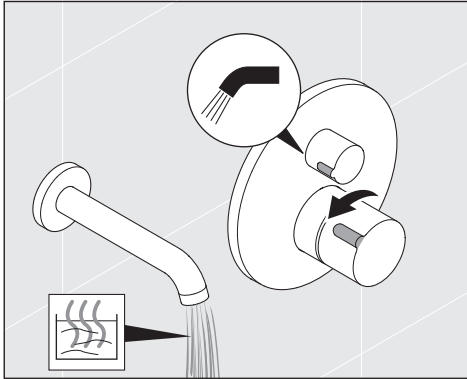

> Check the spout for the hot water.

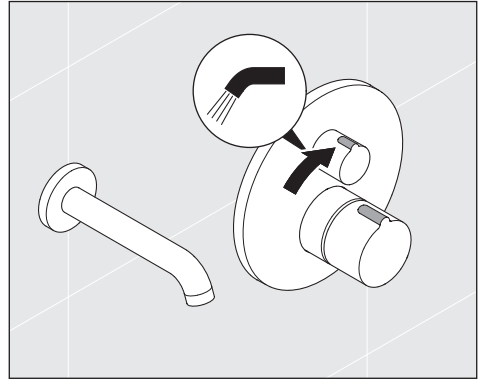

> Turn off the spout.

**Chemical/Cleaners to avoid:**

- Abrasives and polishes, including bleach based cleaners
- Scrubbing bubbles and Lysol basin tub
- Soft scrub, tile cleaner and Windex original
- Fantastic antibacterial heavy duty and comet bathroom cleaner
- Products containing hydrofluoric
- Hydrochloric and/or phosphoric acids
- Anything with caustic agents
- Anything with ammonia, bleach or acid

Chemical/Cleaners recommended:

Mild cleaner (ph7) based on citric acid.

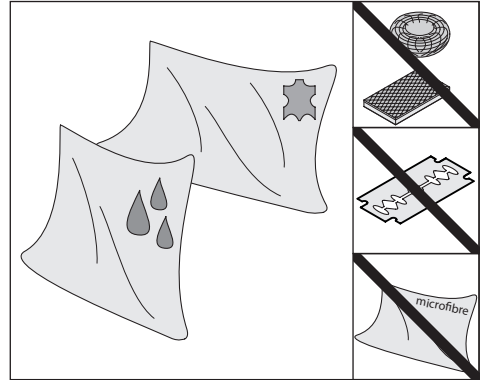
**Cleaning tools to avoid:**

- Abrasive cleaning pads
- Scraping tools
- Abrasive cleaning tools

Cleaning tools recommended:

- Moistened soft cloth
- Leather cloth



en

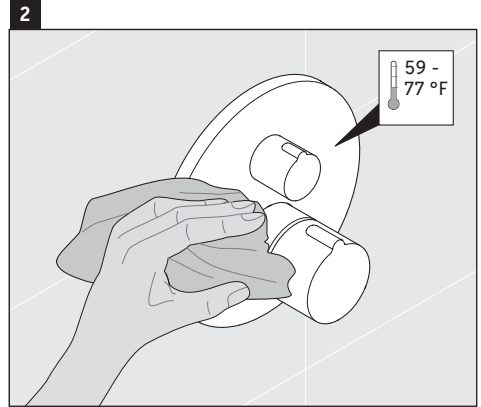

NOTICE **Spray mist can ingress and cause damage to the faucets and fittings**

> Spray cleaner onto the cleaning cloth.

> Ensure that temperature exceed 59 - 77 °F.

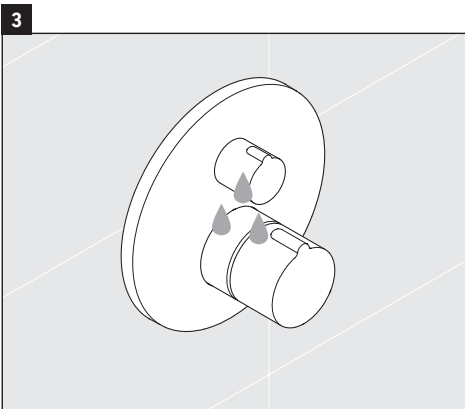

> Rinse cleaner and dirt with water.

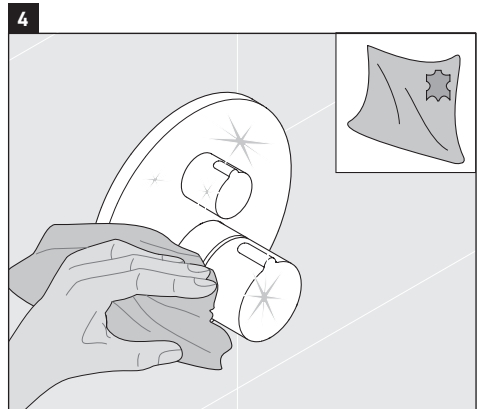

> Dry off faucet with the clean leather cloth.



Ces instructions font partie du produit Duravit et doivent être lues attentivement et conservées en tout temps.

Lectorat ciblé et compétences

Le produit peut seulement être installé par un plombier compétent.

Explication des mots-clés

MISE EN GARDE Indique une situation dangereuse qui, si elle n'est pas évitée, entraînera des blessures mineures ou moyennes.

ATTENTION Répond à des pratiques qui ne sont pas reliées aux blessures physiques.

Données techniques

Pression de fonctionnement max. 72,5 PSI
 Recommandée 43,5 PSI
 Pression de test 72,5 PSI.
 1 MPa = 10 bar = 145 PSI
 Température de l'eau chaude 60 °C (140°F) max.

À utiliser avec des pommeaux de douche d'un débit de 6,1 l/min (1,6 gpm) ou supérieur.



Cette unité répond ou dépasse ce qui suit :

- ASME A112.18.1
- CSA B125.1
- Conforme avec ADA

Instructions sur la sécurité

Blessures et coupures

> Portez des gants lorsque vous installez le produit.

Endommagement d'un produit et/ou d'une propriété

- > Observez les règlements d'installation locaux et les normes nationales particulières en tout temps.
- > Égalisez les différences de pression entre les raccords d'eau froide et chaude.
- > Suivez les instructions du fabricant pour l'installation avec des chauffe-eau sans réservoir.

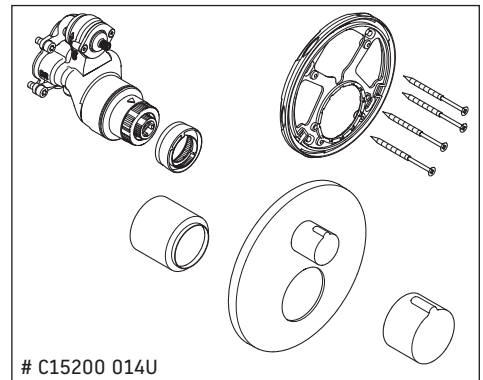
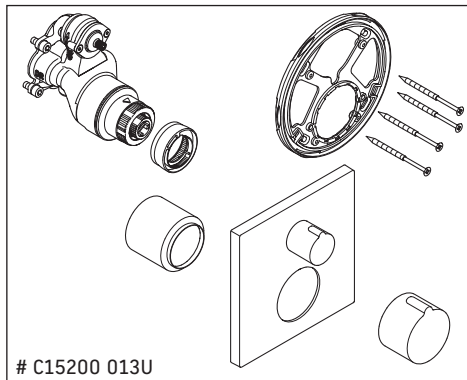
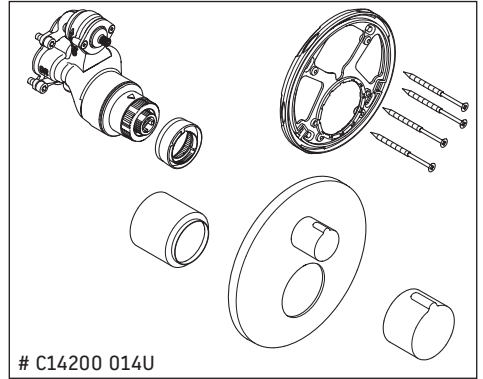
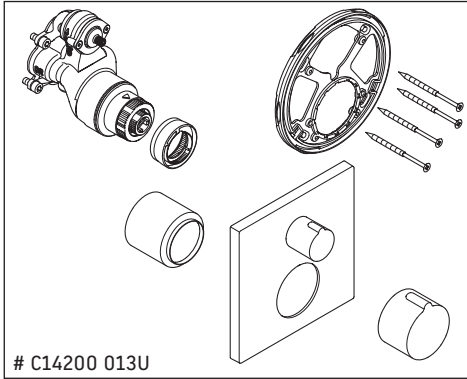



1

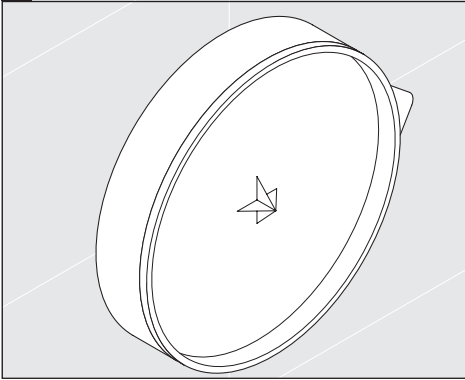

> Enlevez le couvre-poussière.

2

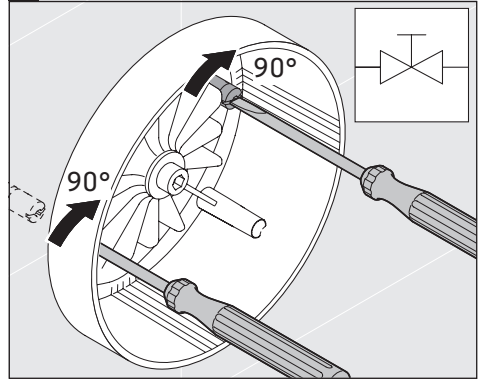

> Fermez les bouchons chaud et froid.

3

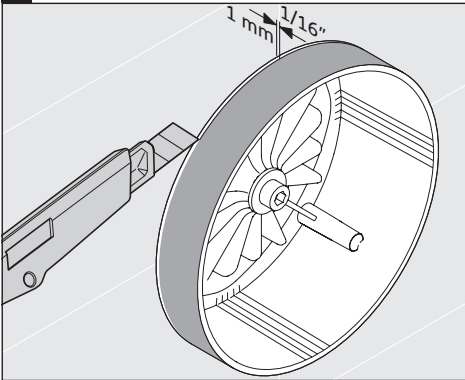

> Coupez le protecteur de plastique pour qu'il se prolonge jusqu'à 1/16 po de la finition de la surface murale.

4

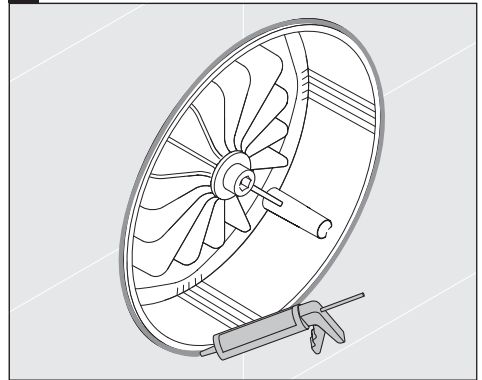

ATTENTION

Dégât d'eau

> Scellez le mur autour du protecteur de plastique avec du silicone sans acide acétique.

fr



5

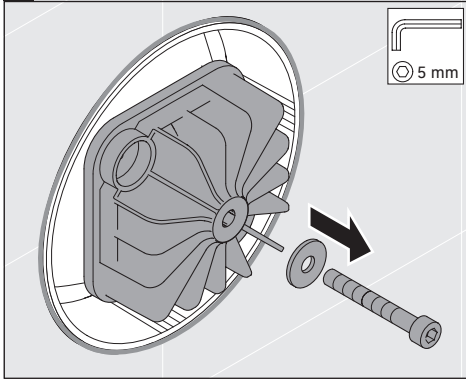

> Enlevez la prise de la tuyauterie et son scellage.

6

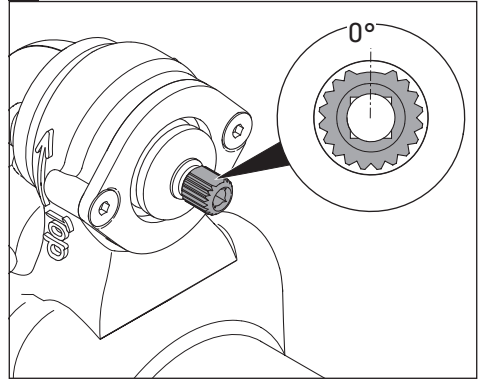

> Fixez la goupille de la valve à 0°.

7

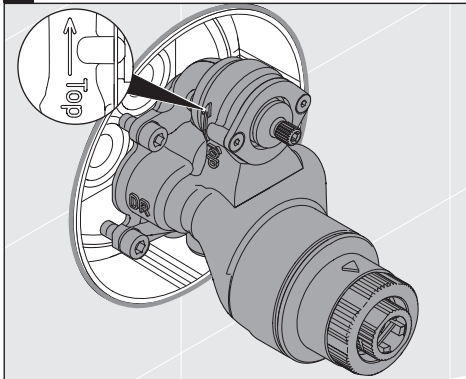

> Installez l'unité fonctionnelle.

8

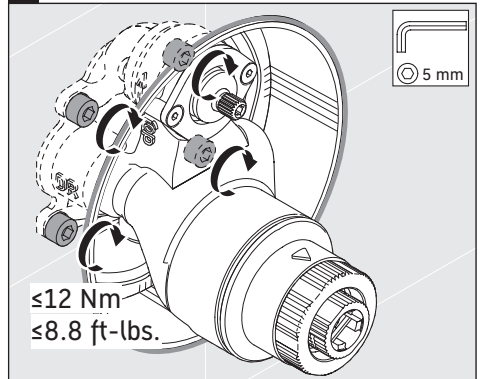

> Installez et serrez les vis d'unité fonctionnelle.
Ne dépassez pas 8,8 pi-lb.



9

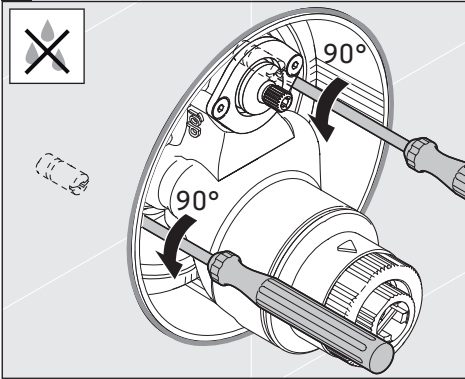

- > Ouvrez les bouchons.
- > Vérifiez qu'il n'y a pas de fuites.

10

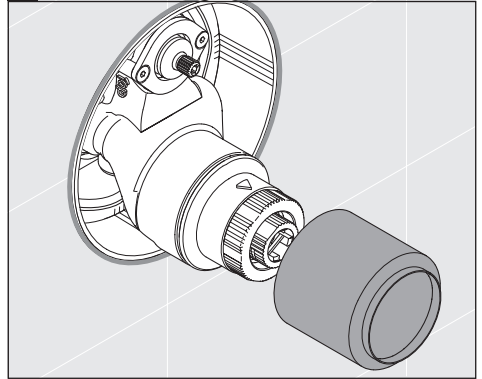

- > Faites glisser le thermostat encastré.

11

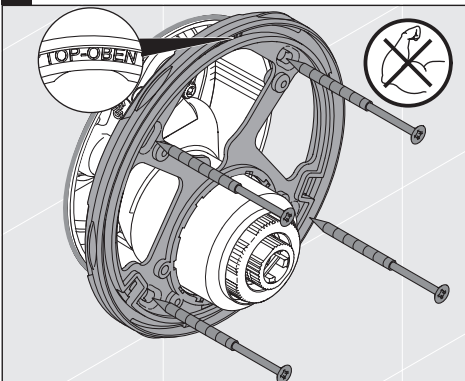

- > Installez le cadre de l'écusson.

12

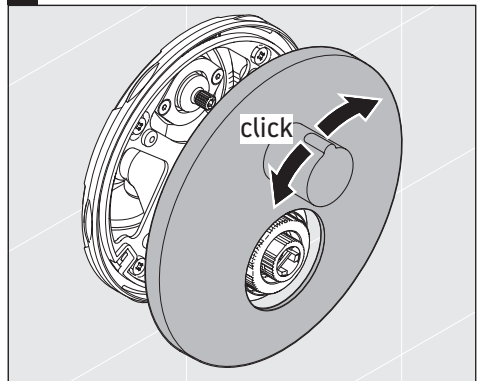

- > Installez l'écusson.

fr

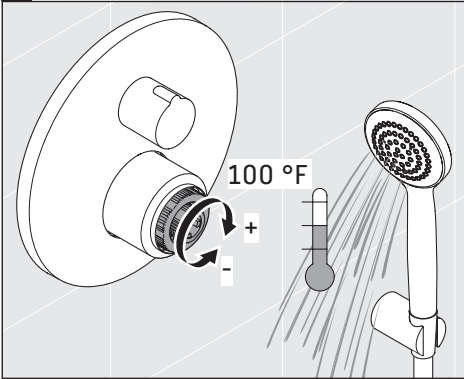
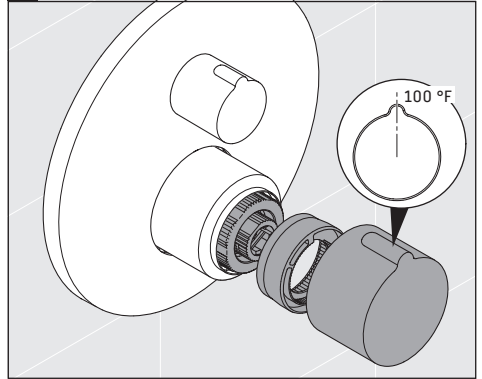
13

14

▲ MISE EN GARDE **L'eau chaude peut entraîner des brûlures**

- > Réglez la limite maximale de la température.
- > Suivez tous les codes de plomberie locaux applicables en réglant la limite maximale de la température.

ATTENTION

Pour éviter les brûlures, la température maximale de la valve de la douche ne devrait pas dépasser 49 °C (120 °F).

À titre d'exemple, au Massachusetts, la température maximale ne peut dépasser 44 °C (112 °F).

> Installez la poignée.



C14200 013U, # C14200 014U

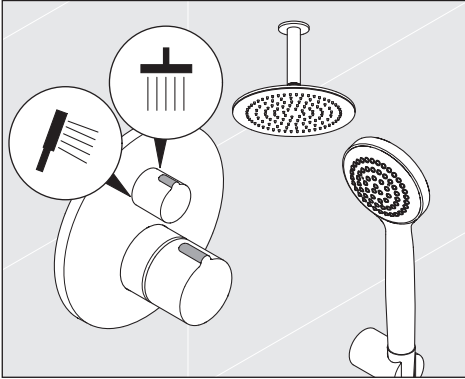

> Ouvrez le pommeau de douche et la douchette.

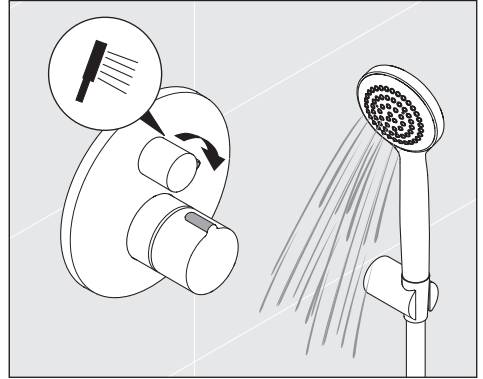

> Tournez la poignée de l'inverseur vers la droite pour activer le pommeau de douche.

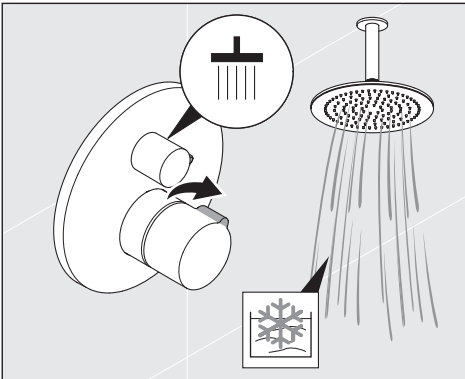

> Vérifiez l'eau froide du pommeau de douche.

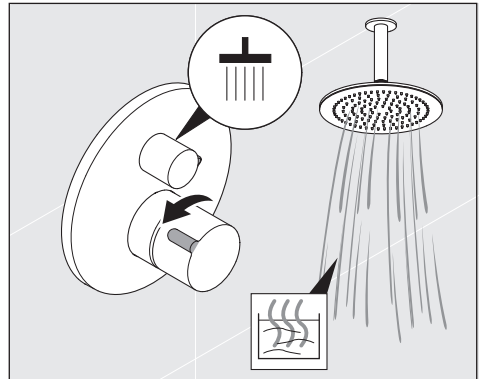

> Vérifiez l'eau chaude du pommeau de douche.

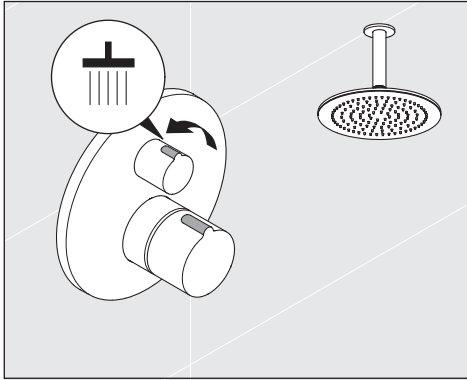

> Fermez le pommeau de douche.

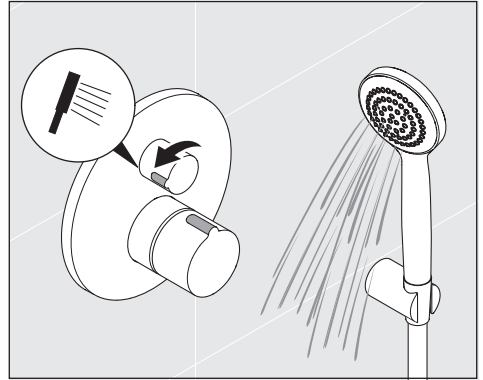

> Tournez la poignée de l'inverseur vers la gauche pour activer la douchette.

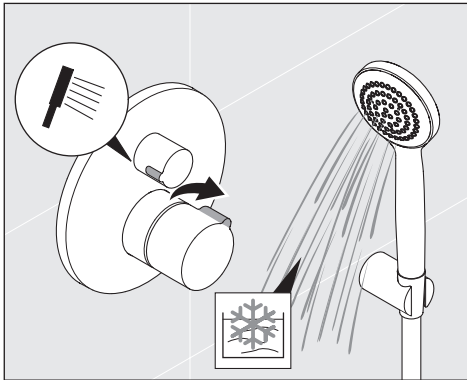

> Vérifiez l'eau froide de la douchette.

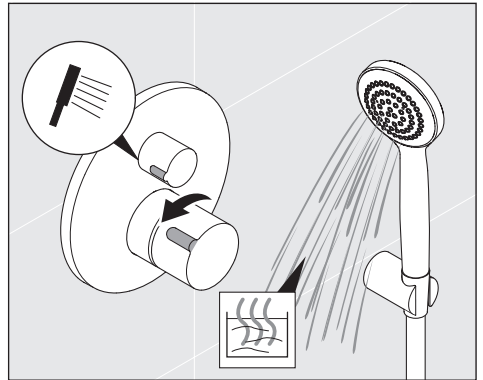

> Vérifiez l'eau chaude de la douchette.



C15200 013U, # C15200 014U

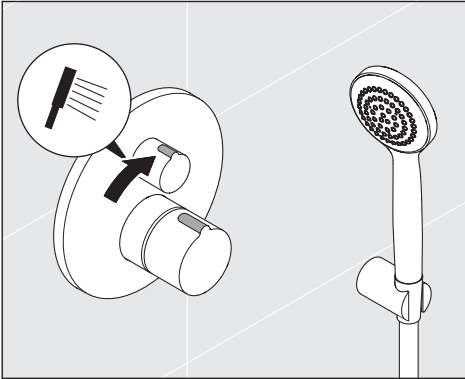

> Fermez la douche.

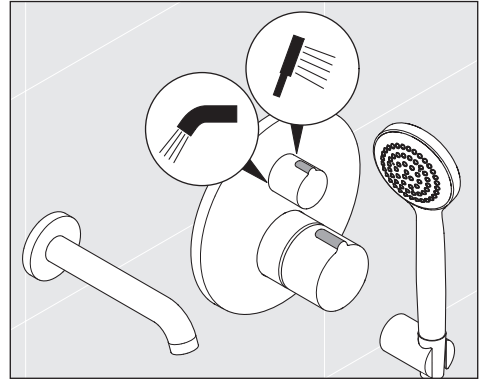

> Il est possible de contrôler le pommeau de douche ou le jet.

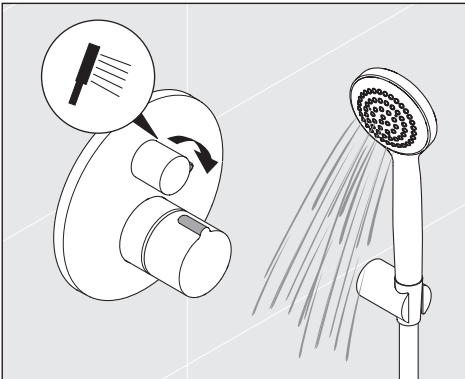

> Tournez la poignée de l'inverseur vers la droite pour activer la douche.

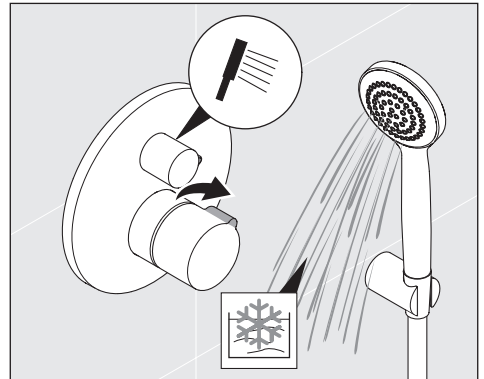

> Vérifiez l'eau froide de la douche.

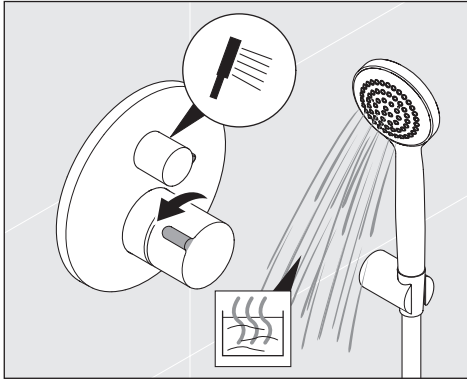

> Vérifiez l'eau chaude de la douche.

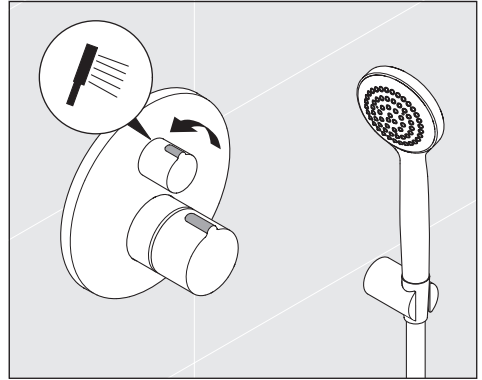

> Fermez la douche.

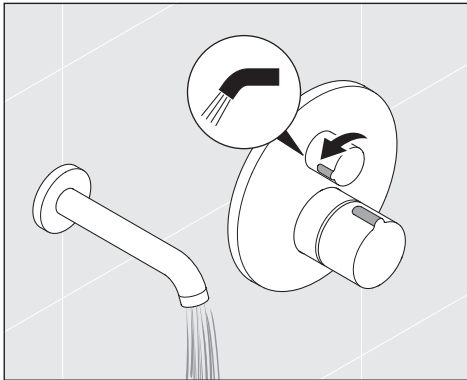

> Tournez la poignée de l'inverseur vers la gauche pour activer le jet d'eau.

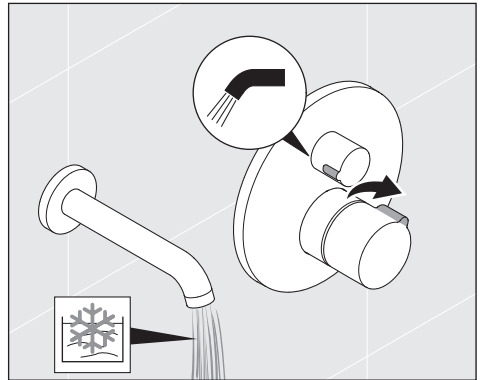

> Vérifiez l'eau froide du jet d'eau.

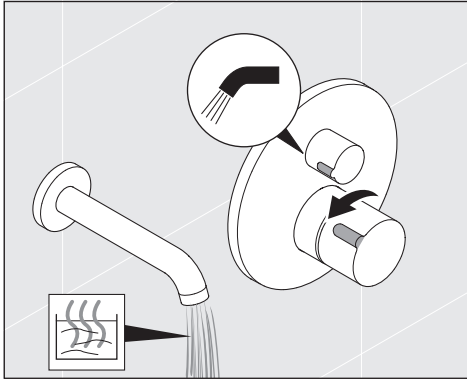

> Vérifiez l'eau chaude du jet d'eau.

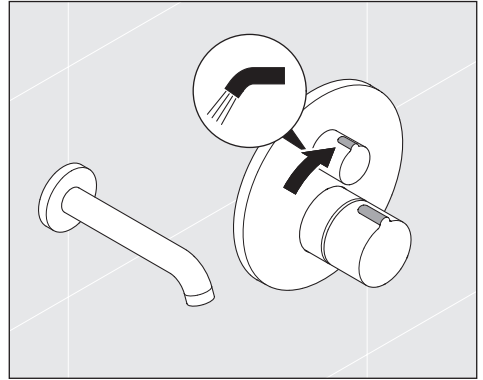

> Fermez le jet d'eau.

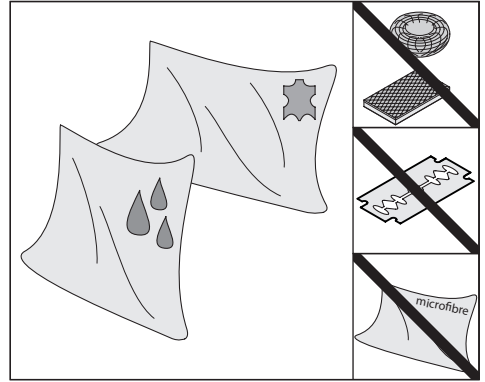

Produits chimiques/nettoyants à éviter :

- Des produits abrasifs et polissant, dont des nettoyants à base de javellisant
- Scrubbing bubbles et Lysol pour la baignoire
- Soft scrub, nettoyant pour carrelage et Windex original
- Fantastik antibactérien puissant et Comet nettoyant pour la salle de bain
- Des produits contenant des acides fluorhydriques
- Des acides chlorhydriques et/ou phosphoriques
- Tout produit contenant des agents corrosifs
- Tout produit contenant de l'ammoniaque, de l'eau de javel ou de l'acide

Produits chimiques/nettoyants recommandés :

Nettoyant doux (ph7) à base d'acide citrique

Outils de nettoyage à éviter :

- Tampons nettoyants abrasifs
- Grattoirs
- Outils de nettoyage abrasifs

Outils de nettoyage recommandés :

- Linge doux humide
- Cuirette



1

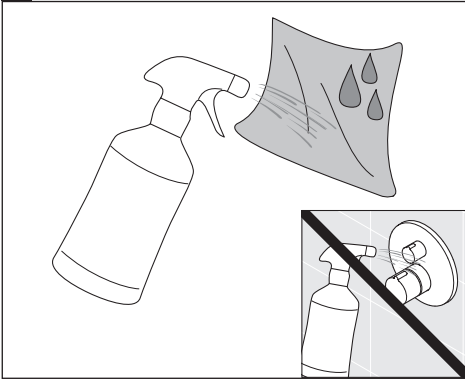

ATTENTION

La fine brume peut s'infiltrer et endommager les robinets et les raccords

> Vaporisez le nettoyant sur le linge.

2

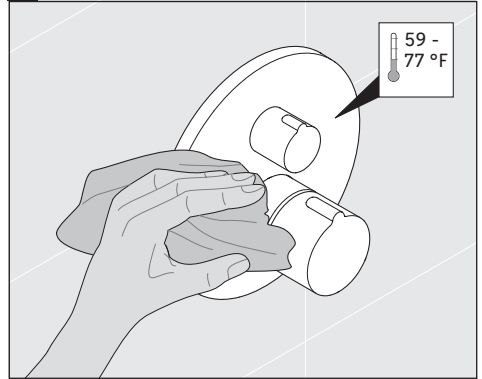

> Assurez-vous que la température dépasse les 15 à 25 °C (59 - 77 °F).

3

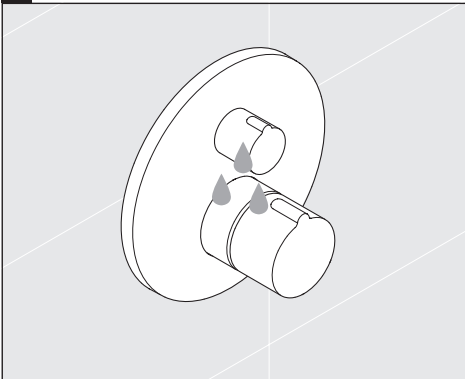

> Rincez le nettoyant et la saleté avec de l'eau.

4

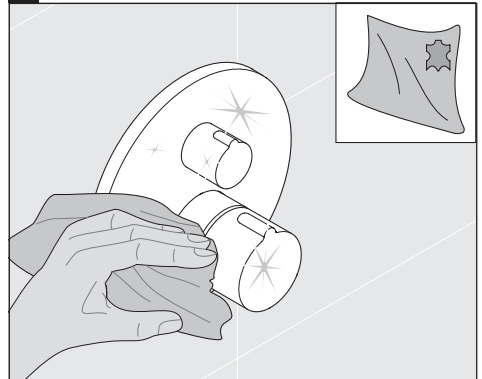

> Séchez les robinets avec la cuirette propre.

fr



Estas instrucciones de montaje forman parte del producto Duravit y es necesario leerlas detenidamente antes del montaje.

Lectores destinatarios y cualificaciones

La instalación del producto solo puede llevarse a cabo por un fontanero cualificado.

Explicación de las palabras clave

ATENCIÓN Indica una situación peligrosa que puede provocar lesiones de gravedad media o leve si no se evita.

AVISO Describe prácticas no relacionadas con lesiones físicas.

Datos técnicos

Presión de funcionamiento	Máx. 72,5 PSI
Recomendada	43,5 PSI
Presión de comprobación	72,5 PSI
1 MPa = 10 bar = 145 PSI	
Temperatura del agua caliente	Máx. 140 °F

Para utilizar con teleduchas con un caudal de 6,1 l/min (1,6 gpm) o superior.



Esta unidad cumple o excede las siguientes normas:

- ASME A112.18.1
- CSA B125.1
- En cumplimiento con ADA

Instrucciones de seguridad

Lesiones por corte y aplastamiento

- > Llevar guantes durante la instalación del producto.

Daños materiales y/o en el producto

- > Observar en todo momento los reglamentos locales de instalación y las normas específicas de cada país.
- > Igualar las diferencias de presión de las conexiones de agua fría y caliente.
- > Observar las instrucciones del fabricante para la instalación de sistemas de calefacción de flujo continuo.

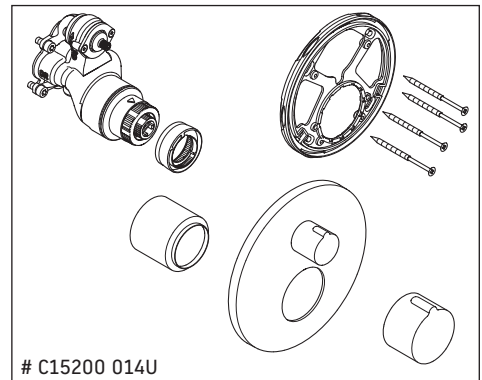
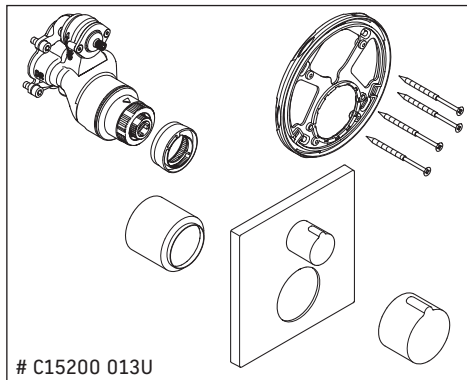
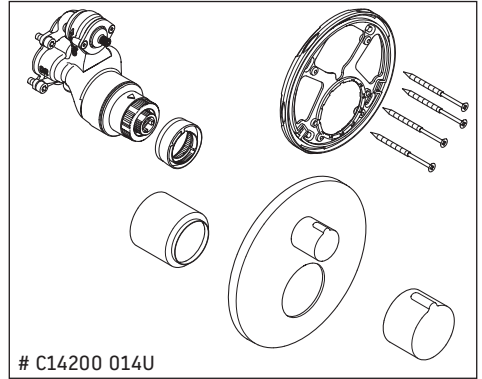
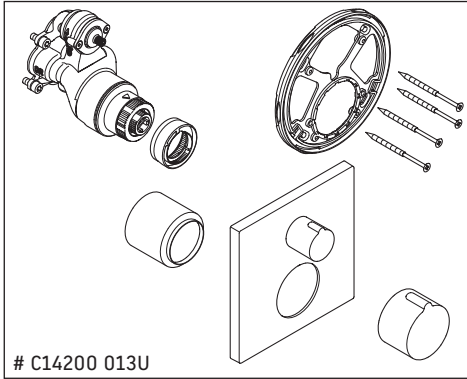

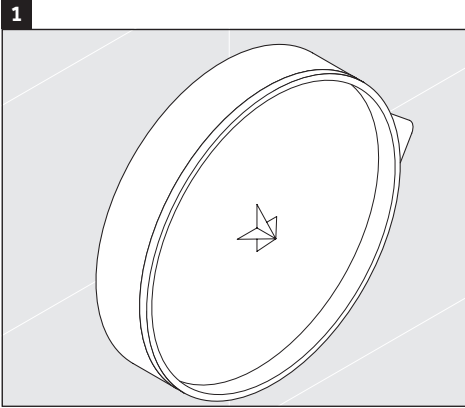

> Retirar la cubierta antipolvo.

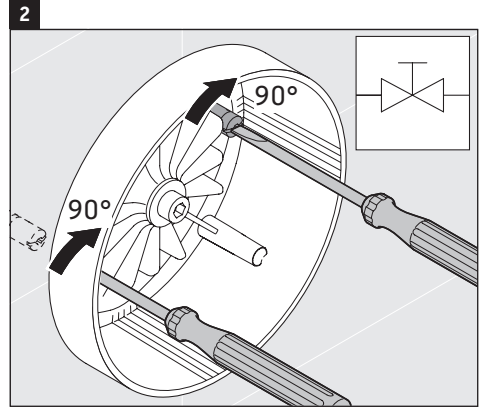

> Cerrar los topes de agua caliente y fría.

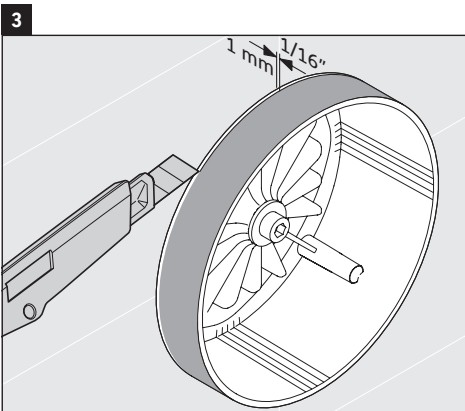

> Cortar la protección de yeso de forma que salga 1/16" sobre la superficie de la pared acabada.

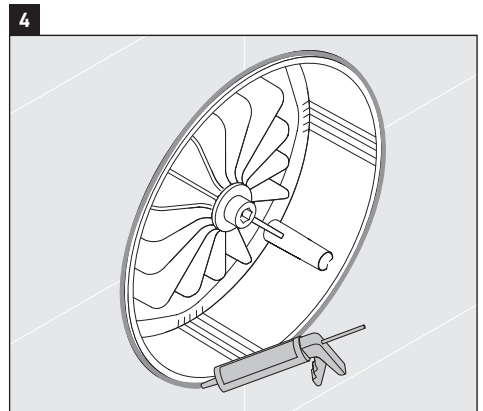

AVISO

Daños por agua

> Sellar la pared alrededor de la protección de yeso utilizando silicona sin ácido acético.



5

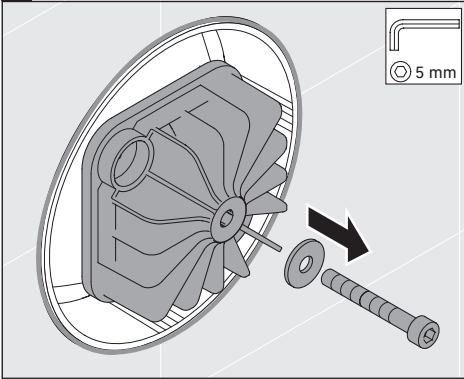

> Retirar el inserto rugoso y las juntas del mismo.

6

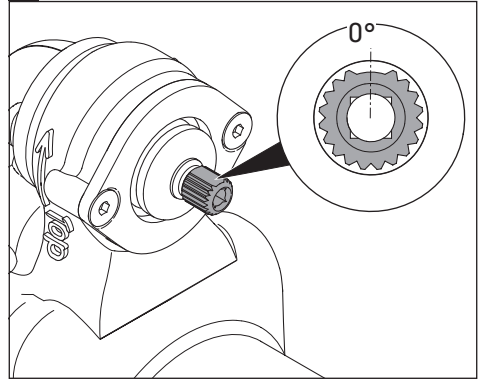

> Ajustar el pasador de válvula a 0°.

7

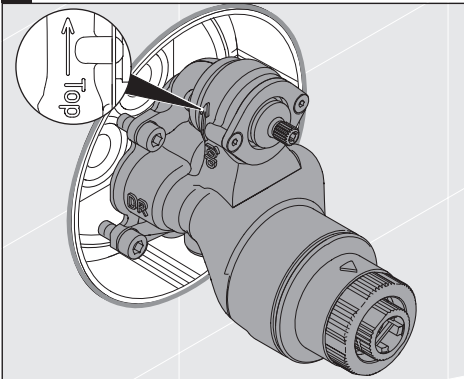

> Instalar la unidad funcional.

8

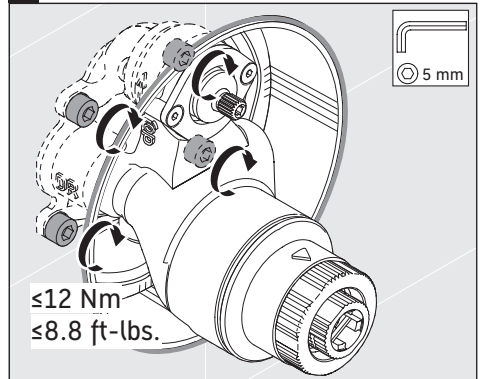

> Instalar y apretar los tornillos de la unidad funcional. No exceder de 8,8 ft-lb.



9

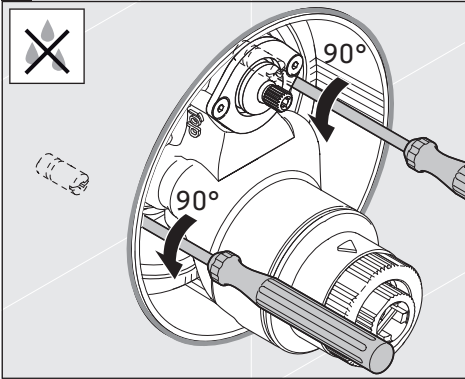

- > Abrir los topos.
- > Comprobar por si hubiera fugas.

10

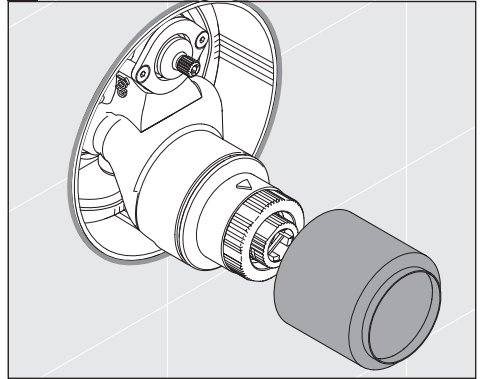

- > Deslizar el manguito del termostato de teleducha.

11

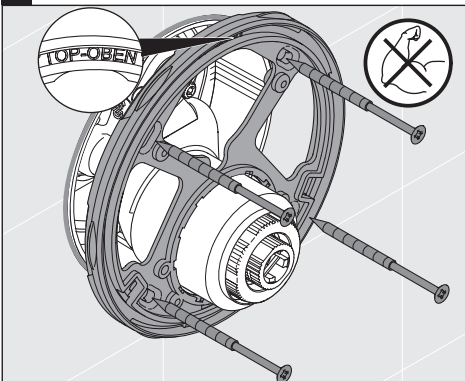

- > Instalar el marco del escudo.

12

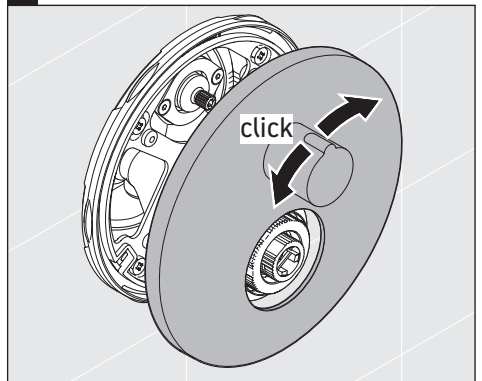

- > Instalar el escudo.

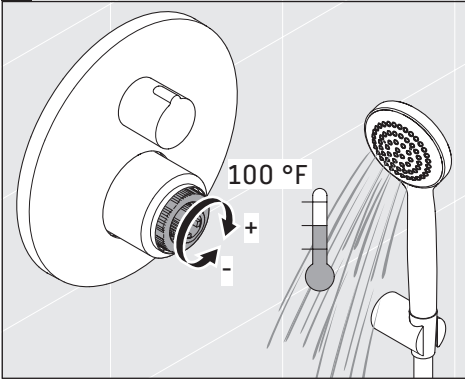
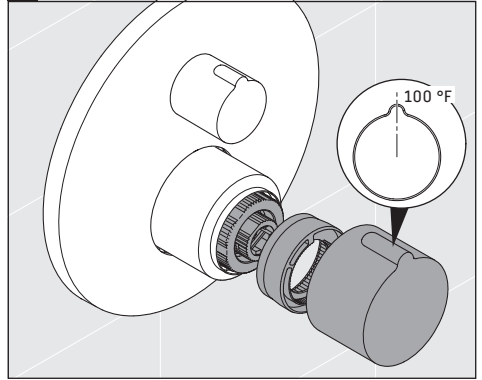
13

14

⚠ ATENCIÓN
El agua caliente puede causar quemaduras

- > Ajustar el límite alto del tope limitador de temperatura.
- > Cumplir todos los códigos de fontanería aplicables a nivel local cuando se vaya a ajustar el límite alto del tope limitador de temperatura.

> Instalar el mando.

AVISO

Para evitar lesiones por quemaduras, la temperatura de salida máxima de la válvula de ducha no debe ser superior a 120 °F. En Massachusetts, por ejemplo, la temperatura de salida máxima no puede ser superior a 112 °F.



C14200 013U, # C14200 014U

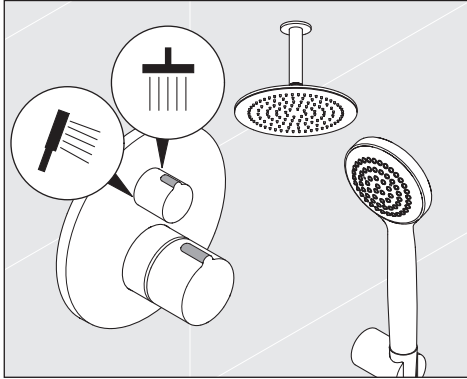

> Abrir el agua de la cabeza de ducha y de la teleducha.

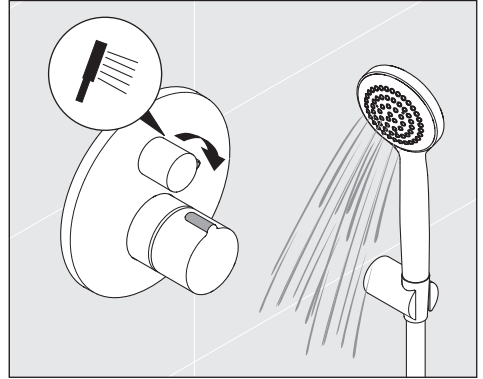

> Girar el mando del desviador a la izquierda para abrir el agua de la cabeza de ducha.

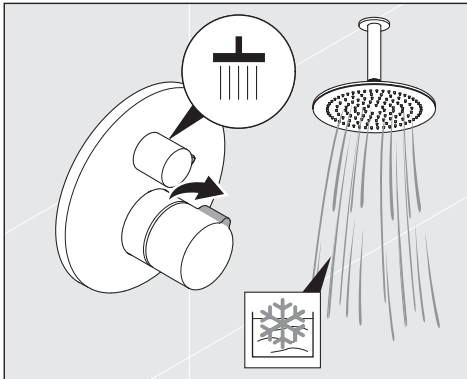

> Comprobar el agua fría que sale por la cabeza de ducha.

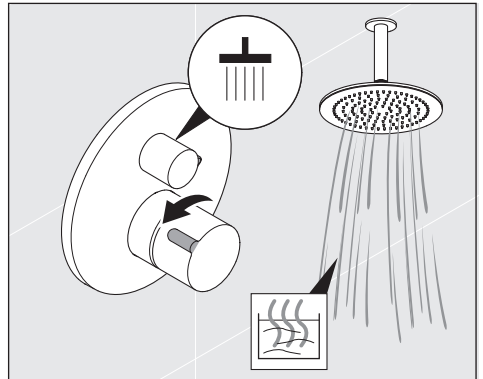

> Comprobar el agua caliente que sale por la cabeza de ducha.

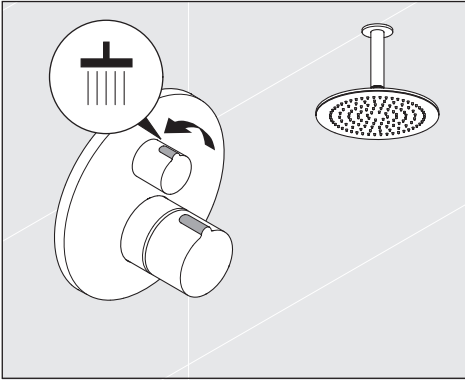

> Cerrar el agua de la cabeza de ducha.

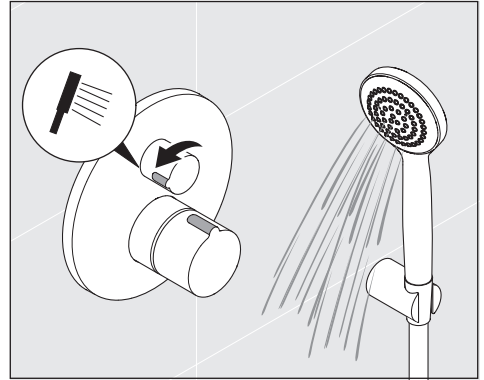

> Girar el mando del desviador a la izquierda para abrir el agua de la teleducha.

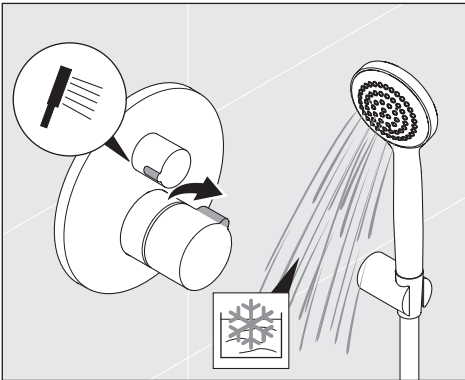

> Comprobar el agua fría que sale por la teleducha.

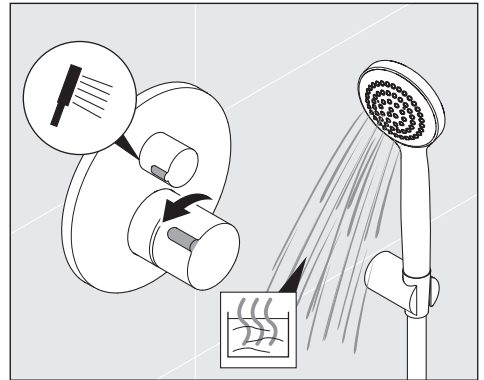

> Comprobar el agua caliente que sale por la teleducha.



C15200 013U, # C15200 014U

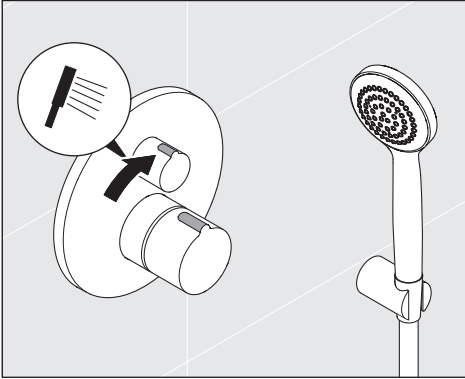

> Cerrar el agua de la teleducha.

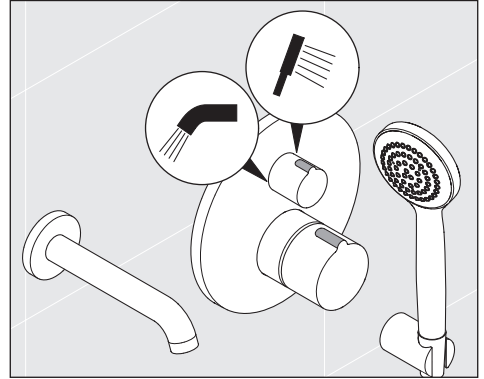

> El control puede utilizarse tanto para la cabeza de ducha como para el llenado.

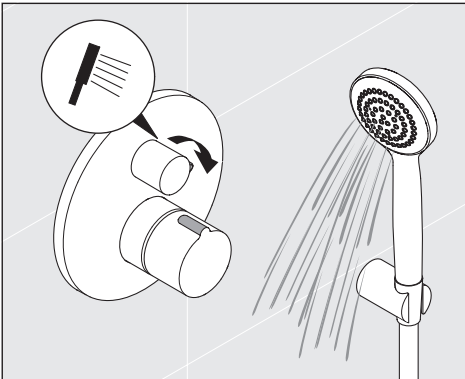

> Girar el mando del desviador a la derecha para abrir el agua de la teleducha.

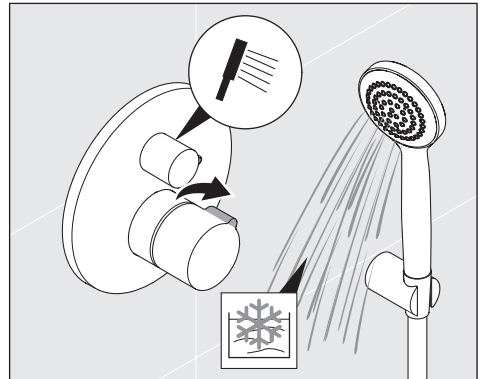

> Comprobar el agua fría que sale por la teleducha.

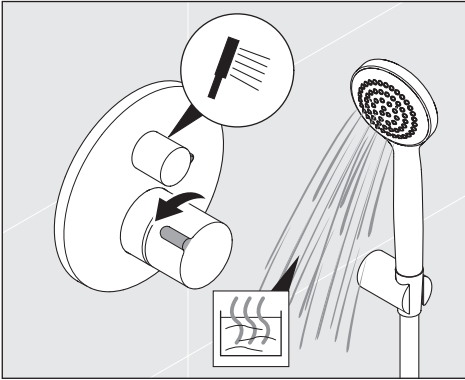

> Comprobar el agua caliente que sale por la teleducha.

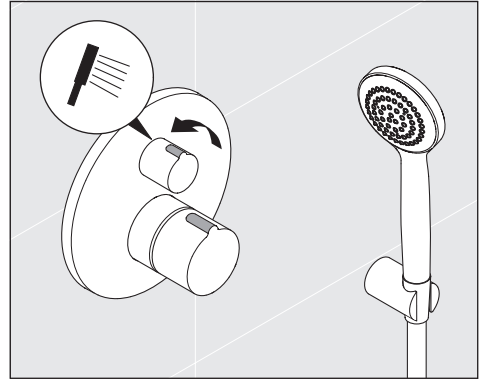

> Cerrar el agua de la teleducha.

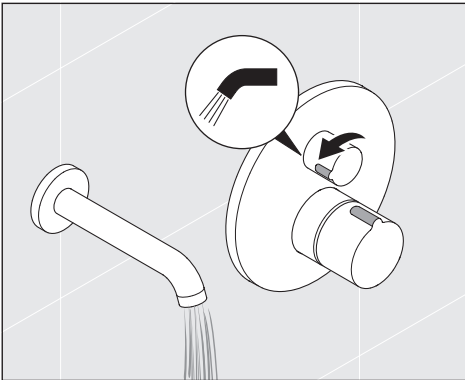

> Girar el mando del desviador a la izquierda para abrir el llenado.

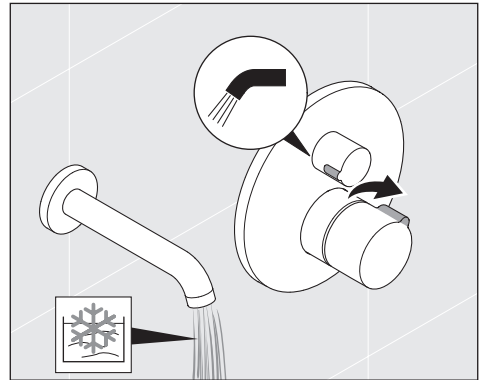

> Comprobar el agua fría del llenado.

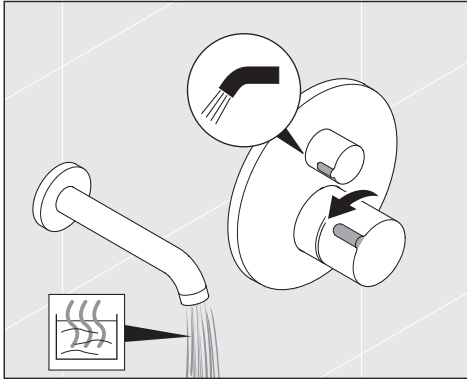

> Comprobar el agua caliente del llenado.

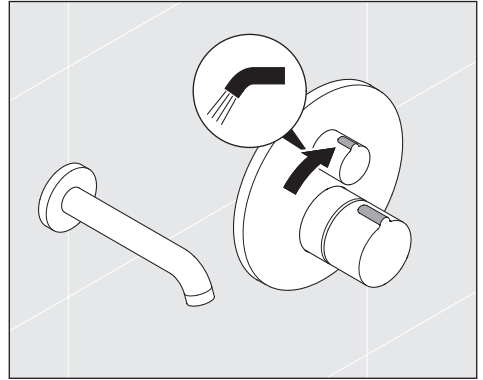

> Cerrar el llenado.



Productos químicos/limpiadores que se deben evitar:

- Productos abrasivos y abrillantadores, incluidos los productos de limpieza con base de lejía
- Burbujas de limpieza y Lysol para lavabos
- Cepillo de cerdas suaves, producto para limpiar azulejos y Windex original
- Fantástico producto de limpieza para baños Comet, antibacteriano y altamente resistente
- Productos que contienen ácido fluorhídrico
- Ácidos clorhídricos y/o fosfóricos
- Cualquier producto con agentes cáusticos
- Cualquier producto con amoníaco, lejía o ácidos

Productos químicos/limpiadores recomendados:

Producto de limpieza suave (ph7) con base de ácido cítrico.

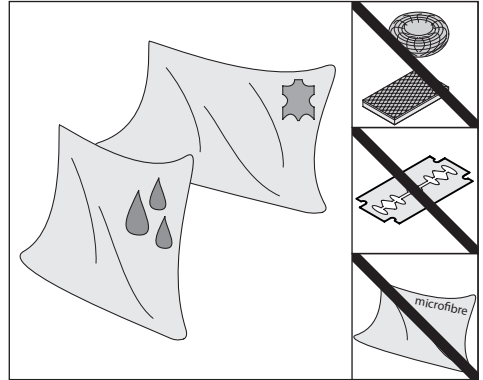

Herramientas de limpieza que se deben evitar:

- Esponjas limpiadoras abrasivas
- Raspadoras
- Herramientas de limpieza abrasivas

Herramientas de limpieza recomendadas:

- Paño suave humedecido
- Gamuza de piel natural

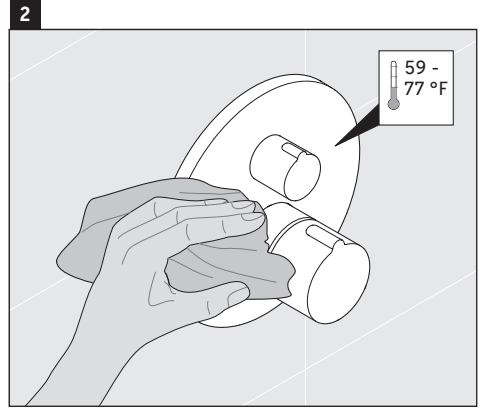
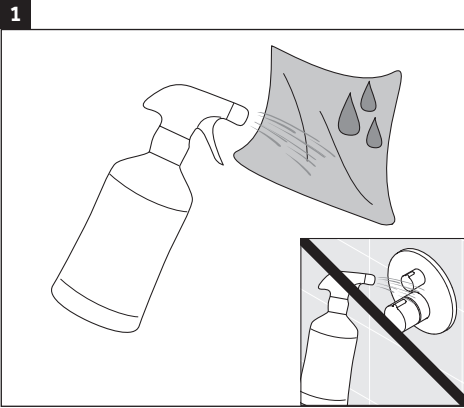

AVISO

La neblina de spray puede penetrarse en la grifería y los accesorios y dañarlos

> Aplicar el producto de limpieza en el paño.

> Asegurarse de que la temperatura no sea superior a 59-77 °F.

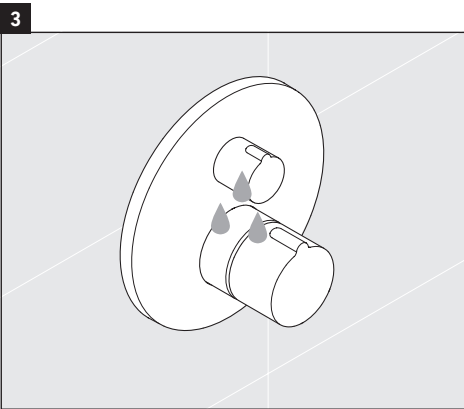

> Aclarar con agua para eliminar el producto de limpieza y la suciedad.

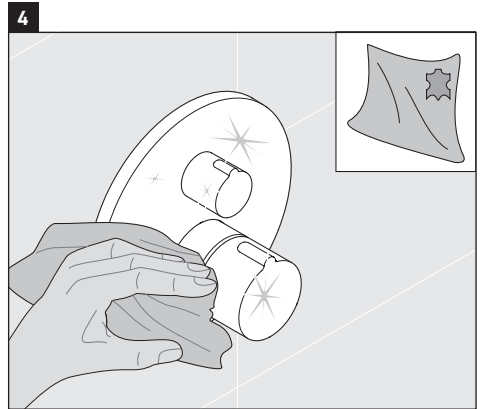

> Secar la grifería utilizando una gamuza limpia de piel natural.

DURAVIT USA, INC.
2635 North Berkeley Lake Rd., Ste. 100
Duluth, GA 30096
Toll Free 888-DURAVIT
Phone 770-931-3575
Fax 770-931-8454
info@us.duravit.com
www.duravit.us

