

Electronic Exposed TECK® Flush Valve

TECK®
COMMERCIAL

DELTA

81T201HWA-42-MMO
Exposed Hardwire Operated
1-1/2" Top Inlet Closet Fixture



- Polished chrome plated vandal resistant metal cover with top mounted sensor operated **H₂Optics®** electronics
- True mechanical manual override button**
- Right or left-hand supply installation
- ADA compliant, automatic operation hardwire powered infrared sensor
- Scratch resistant replaceable lens window
- Supplied with an advanced infrared sensor activated flush system that uses precise user distance measurements along with a bowl length setting to activate the correct flush for each usage
- Hardwire adaptor 24 VAC to 6.4 VDC converter (supplied)
- Vandal resistant copper tube conduit
- Optional 24 hour automatic flush factory set to off
- Set-up sensor range adjustment indicator lights
- 24 VAC input, 6 second arming delay
- Electronic operated non-hold-open **metal** override button with 5 second lockout (110 to 24 VAC Transformer not included. See selection below for additional part number.)
- TECK® exposed diaphragm flush valve
- Chloramine resistant diaphragm
- Forged brass diaphragm retainer
- Renewable seat
- Polished chrome plated body
- External water conserving flush adjustment**, factory set to 4.2 litre (1.1 gal.), **Not field adjustable**
- 1" FIP/Copper sweat inlet adaptor**, angle check stop with protecting cap
- Adjustable 121mm (4-3/4") plus or minus 11mm (7/16") inlet/valve outlet centers
- Vacuum breaker
- Cover tube, wall flange, spud flange, concealed spud nut, and 292mm (11-1/2") outlet tube
- Recommended water supply:**
Minimum flowing pressure – 25 psi (172 kPa)
Minimum flow rate – 25 gpm (95 L/min)
- 4.2 Lpf (1.1 gpf) valve is recommended for new construction only

APPROVALS:

- IAPMO listed to ASSE 1037/ ASME A112.1037/CSA B125.37
- Indicates compliance to ICC/ANSI A117.1

(Contact Delta Representative for State and/or Local Approvals.)

Patented



Engineer/Architect Approval

Model Specified:

Approval:

Date:

81T201HWA-42-MMO-BL



81T201HWA-MMO-BL

Same as 81T201HWA-42-MMO, but **external water conserving flush adjustment** factory set to 6 Lpf (1.6 gpf), Matte Black cover and body

81T201HWA-42-MMO-BL

Same as 81T201HWA-42-MMO, but Matte Black cover and body

81T201HWA-48-MMO-BL

Same as 81T201HWA-42-MMO, but factory set to 4.8 Lpf (1.27 gpf), **Not Field Adjustable**, Matte Black cover and body



AVAILABLE OPTIONS FOR FIELD CONVERSION

061047A

Hardwire with Battery Backup

See **DSP-BB** for detailed specification.

✓	TRANSFORMERS	
	060704A	110 to 24VAC Class 2 20 VA (for up to 5 Electronic Valves)
	060771A	110 to 24VAC Class 2 40 VA (for up to 10 Electronic Valves)

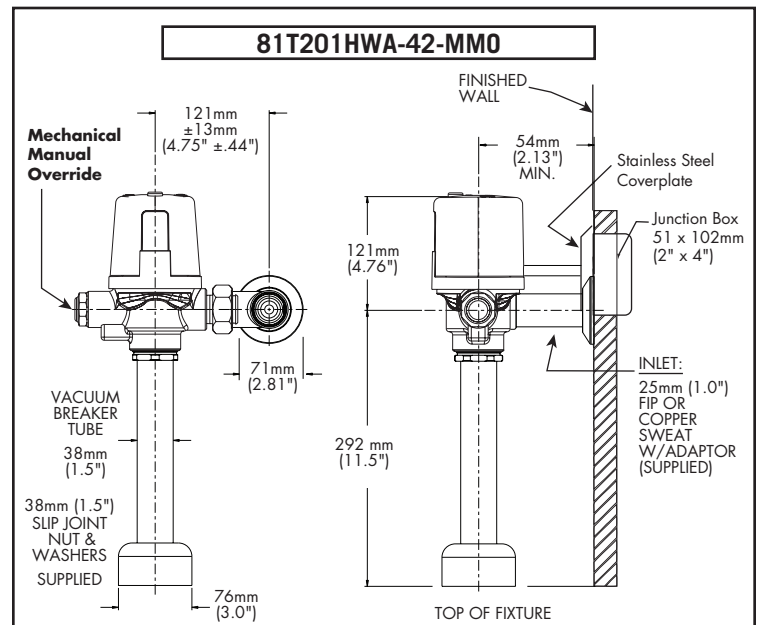

Note: For high and low pressure applications, please see page FEA-81T High Water Pressure note for more details.

Verify flow requirements with bowl manufacturer.

Note: Measurements may vary ± 6mm (0.25")

Refer to www.specselect.com for individual models.

Note: Use this page as a product submittal sheet.