

## SPECIFICATION: (EXAMPLE)

### □ 55P1513

- 203mm (8") **heavy-duty cast brass** wallmount pre-rinse faucet.
- Integral check stops.
- Polished chrome plated finish.
- **TUF-TECK**<sup>®</sup> compression structures.
- ADA compliant, color-indexed, 76mm (3.0") metal lever blade handles.
- 9.5 mm (3/8") IPS rigid riser, heavy-duty gooseneck spring, 1118mm (44") stainless steel clad high pressure rubber hose.
- 1.6 gpm (6.08 L/min) @ 60 PSI spray head, self-closing, insulated stop valve, spray head hook.
- *(LESS wall bracket, LESS thin wall installation kit, LESS water/energy saving spray plate).*

### Engineer/Architect Approval

Model Specified:

Approval:

Date:

### □ 55P1000

- 305mm (12") adjustable length riser wall bracket, thick wall extension pipe, **vibration resistant** compression connector, polished chrome plated finish.



55P1000

### □ 55C1090 (See back page)

- Add-On Faucet
- Standard 1.5 gpm (5.7 L/min) flow control aerator



55P1513

# Pre-Rinse Faucets

**TECK<sup>®</sup>**  
COMMERCIAL

**DELTA**



## APPROVALS:

- CSA certified
- Complies to ASME A112.18.1/CSA B125.1
- For commercial use only
- Handle meets ADA compliance to ICC/ANSI A117.1/ADA
- Verified compliant with 0.25% weighted average Pb content regulations

(Contact Delta Representative for State and/or Local Approvals.)

## FLOW RATE vs PRESSURE

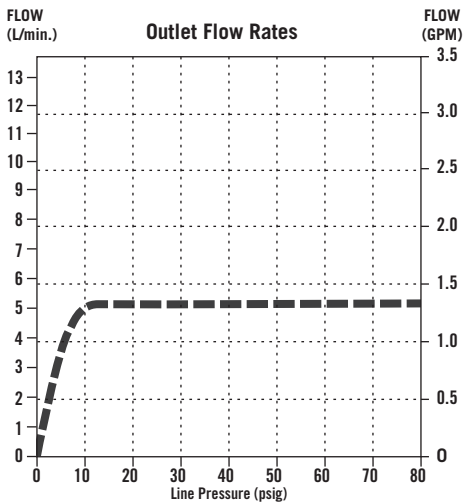

Spout Outlet

Spray Face for 55P1513 (not shown)  
 1.6 GPM @ 60 PSI

## INLETS - 1/2" FIP/MIP

Note: Measurements may vary  $\pm 6\text{mm}$  (0.25")

**MODEL No. 55C1090**  
 Will add 152mm (6") to overall height

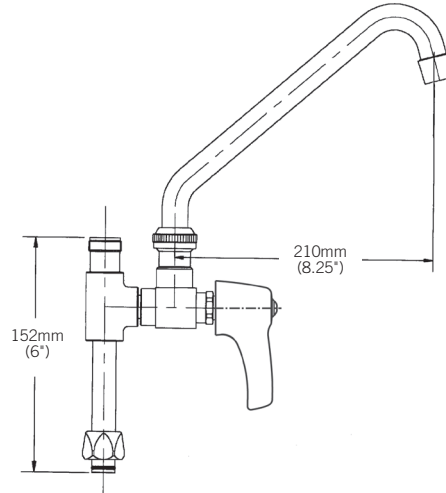

**FOR OPTIONAL SWING SPOUTS**  
 See DSP-S/S for detailed specification.

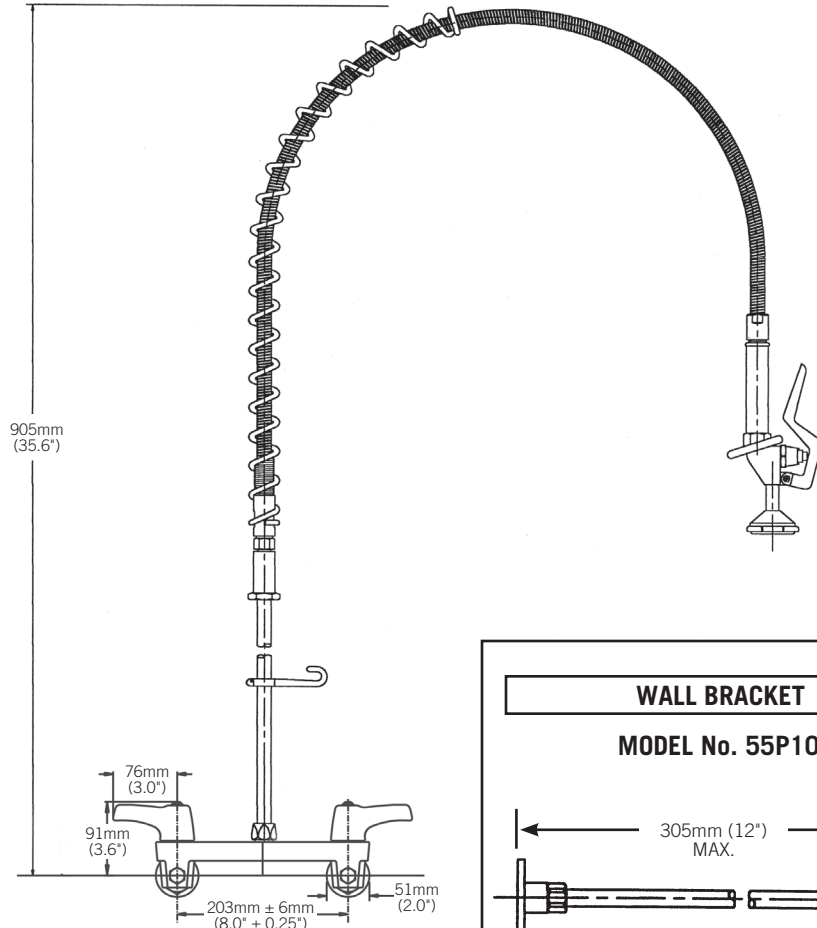

## WALL BRACKET

**MODEL No. 55P1000**

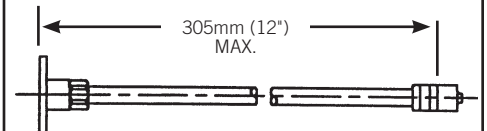

Refer to [www.specselect.com](http://www.specselect.com) for individual models.

Note: Use this page front and back as a product submittal sheet.