



DELTA

Electronic Exposed TECK® II Flush Valves (with H2Optics®)

212381

212381

212381

212381

212381

212381

212381

212381

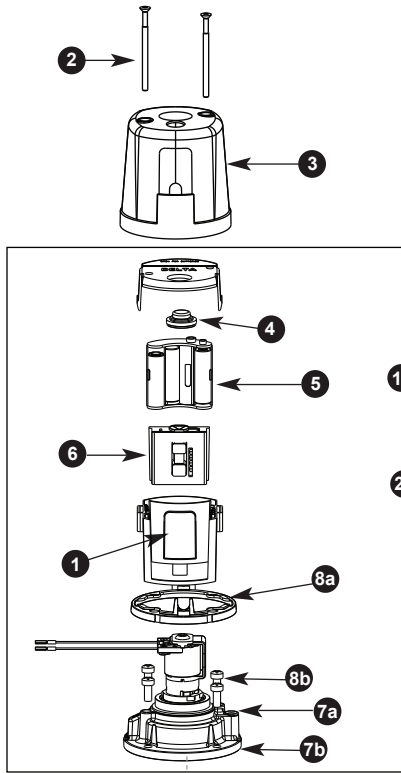

Record model number:

81T2 **1** **A** - - - **DF**

Valve Type

0 = W/C (Water Closet)
2 = W/C - 22" outlet tube

Power Option

BT = Battery
HW = Hardwired

Additional Options

(leave blank if not applicable)
30 = w/Sloan ZurnTail
20 = Less Stop Assy
1 = V/B Tube w/Tee Assy (WC only)

Flush Volumes

(leave blank - not applicable)

Dual Flush Option

DF = dual flush

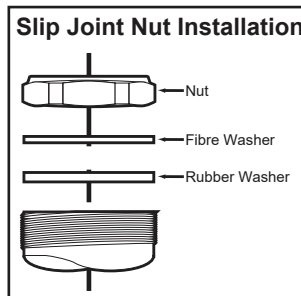
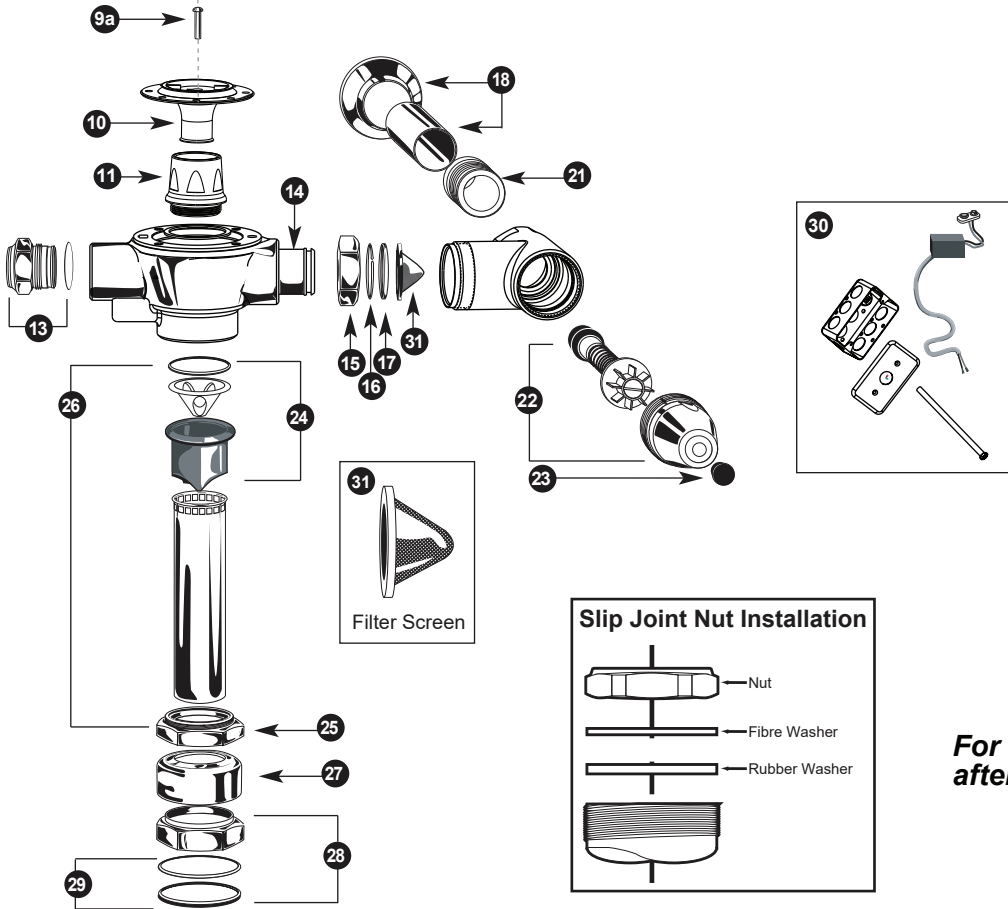
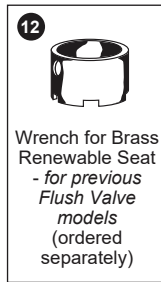

For valves manufactured after January 2013.

PLEASE LEAVE this M&I Sheet with the owner, maintenance plumber, etc. as items relating to ongoing maintenance suggestions and procedures are included.

Item #	Part #	Description
1	061063A	Replaceable Lens for 3rd Generation E-FV
2	061138A	Cover Screws for 3rd Generation E-FV
3	061139A	Metal Cover for 3rd Generation E-FV
4	see #6	Electronic Button Head Assembly
5	060334A	Battery Holder
6	061363A	Water Closet Board and Electronic Override Button
7	061024A	Regulating Screw & O-Ring
8a	061169A	Cast Cap/Solenoid & Regulating Screw Assembly
8b	061141A*	Cover Gasket (3/pkg)
9a	060078A*	Screws for Cast Cap (4/pkg)
9b	060507A	Water Closet Poppet Pin Pack (3/pkg)
10	061323A	Diaphragm/Guide Assembly - WC
	060079A-MMO	Diaphragm Package
11	062007A	Brass Seat with O-ring
12	060341A	Wrench for Brass Renewable Seat (ordered separately)
13	060342A	Union Nut CP
14	060506A	Plug & O-Ring for Handle End
15	060735A	Retaining Ring
16	060692A	Standard Adjustable Tail CP
17	060082A*	Adjustable Tail O-Ring Package (20/pkg)
18	060504A	S/S Wall Flange & Cover Tube
19	061142A	Electronic Water Closet Repair Kit for 3rd Generation E-FV
20	061144A	Electronic Water Closet Repair Kit for DF 3rd Gen E-FV

* Package Quantities May Change. Check the parts section of the latest Delta Commercial Faucet Price List for current quantities.

** Each individual sensor module requires its own 24 VAC to 6 VDC hardwire converter.

Item #	Part #	Description
21	060697A	1" Copper Sweat Inlet Adaptor
	060694A	3/4" Copper Sweat Inlet Adaptor
	060764A	3/4" FIP Inlet Adaptor
22	060843A	Retrofit Check Stem Unit, Capnut & Button Complete
	060844A	Seat Washer, Spring, Button & O-Ring Kit
	060859A	Angle Stop with Union Nut & Tail Complete
23	060081A*	Plug Button Package (12/pkg)
24	060785A	VB Sleeve Complete
25	060094A	CP Male Threaded Coupling Ring
26	060782A	1 1/2" x 10" VB, Ring & Tube Complete (for 81T201)
	060783A	1 1/2" x 22 3/4" VB, Ring & Tube Complete (for 81T221)
	060784A	3/4" x 11 1/2" VB, Ring & Tube Complete (for 81T231)
	060781A	1 1/2" x 10" VB, Side Outlet Tee Tube Complete
27	060004A	1 1/2" Spud Flange
	060463A	3/4" CP Coupling Nut, 3/4" Washer & 3/4" Spud Flange
28	060778A	1 1/2" Rough Coupling Nut & Washer
	060463A	3/4" CP Coupling Nut, 3/4" Washer & 3/4" Spud Flange
29	060083A*	1 1/2" Rubber Slip Joint Washer (12/pkg)
30	061069A	Hardwire Converter & Rigid Connection Assy for 3rd Gen E-FV
31	060344A	Filter Screen Kit (12/pkg) for Teck tails
	060704A	Transformer (110 to 24 VAC) for 5 Sensor Modules**
	060771A	Transformer (110 to 24 VAC) for 10 Sensor Modules**

Product #	A	B	C
	Max.	± 11mm (7/16")	Min.
All 81T201BT/ 81T201HW variations*	292mm (11 1/2")	121mm (4 3/4")	54mm (2.13")

* Note: -30 models, B = 114mm - 131 mm (4.5" to 5.18")

BEFORE THE FIRST FLUSH (COMPLETE VALVES)

FLUSH BOTH OLD AND NEW PIPES:

It is important to FLUSH and CLEAN thoroughly both new and old water piping to ELIMINATE contaminants (eg. scale, sediment, gravel, cuttings, solder, etc.) from the line.

Where the water has a sediment content, a PIPE STRAINER in the supply line should alleviate that condition and protect working parts of flushometers and faucets.

On a NEW INSTALLATION, always flush the valve 4 or 5 times to clean out supply line debris. It is also advisable where more than one flushometer is installed on a water line, to flush out the water piping through the last flushometer outlet of the pipe line.

INSTALL FILTER SCREEN (included):

Note: Place filter in stop bore with conical screen facing the water flow.

Caution: Do not push filter in too far. Let filter seat against face of flush valve tail. Periodic cleaning of the filter screen with water is recommended depending on local water conditions to remove any dirt or sediment. See filter screen M&I for additional installation information.

ELIMINATE AIR FROM VALVES:

The FIRST FLUSH should ELIMINATE all air from the TECK flushometer. DO NOT ADJUST flushometer based on the results of the first flush.

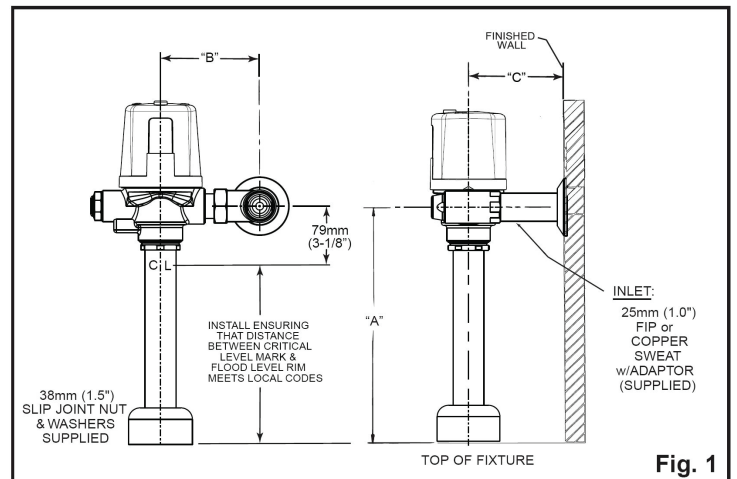

Fig. 1

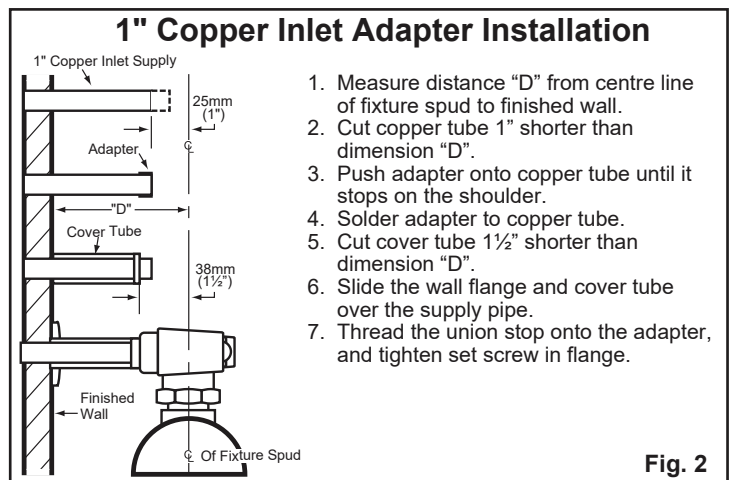

Fig. 2

TO PREVENT WATER HAMMER:

A water hammer arrestor may be installed at the last flushometer and/or at the back of an individual installation. This assures SMOOTHER OPERATION of the valves and longer life for the working parts.

HANDS SHOULD BE CLEAN AND FREE OF GREASE AND OIL during any maintenance or handling of electronic housing components to prevent possible damage to internal circuitry.

IF LEFT HAND STOP REQUIRED:

- Remove the cover by taking out the two cover screws. See Figure 4.
- You will now see the clear electronic compartment with a grey cover.
- Now take hold of the compartment and very carefully, slowly lift the compartment about 1/4" and turn it 180°.
- The sensor eye should now be on the other side.
- Gently push the compartment back down, aligning the two screw holes on the clear case with the screw holes on the brass solenoid cap.
- Rotate cover gasket 180° on brass cap.
- Check for pinched wires between cover and clear case.
- Ensure grey cover is snapped onto clear case and chrome button is properly seated.
- Replace the cover and two cover screws - do not overtighten cover screws.

Flush volume adjustment:

1.60 U.S. gallons / 6.0 litres for water closets

The Regulating Screw (061024A, item #7) may be adjusted, according to job conditions and fixture installed to the proper water volume to flush that particular fixture.

NOTE: 6.0 Litre water closets may require the Angle Stop to be set at only ONE TURN OPEN. For a SHORTER flush, turn the Regulating Screw (061024A, item #7) left (counter-clockwise) and right (clockwise) for a LONGER flush.

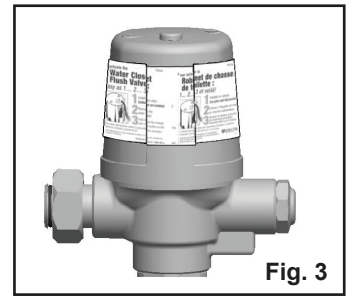

Fig. 3



Fig. 4

INSTALLATION INSTRUCTIONS - BATTERY FLUSHOMETER (for Hardwire, skip to Step 3)

Step 1:

- Install battery flushometer to fixture.
- Open inlet stop.

Step 2:

- Follow instructions on yellow static label (Figure 3). **Note: The batteries are already installed and the product is in hibernation mode waiting to be activated.**
- After you remove the yellow label, you must push the electronic override button three times within five seconds to activate the valve and to place it into operation mode. To signify the valve has entered operation mode, you will see an ascending and descending light sequence.
- **Proceed to Step 5.**

INSTALLATION INSTRUCTIONS - HARDWIRED FLUSHOMETER

Step 3:

- Before installing the flush valve body. Install 2" x 4" electrical box into wall with centre of box in line with the cut-out in the back of the metal flush valve cover. See Figure 5.
- Securely attach box to wall structure. **⚠** Install CSA and/or UL approved Class 2 transformer or equivalent in a convenient location or in a pipe chase. **(Do NOT install the transformer inside the control box.)** Run suitable wires from 24 VAC step down transformer into the electrical box. The transformer is to be installed in an adjacent accessible space. Use cable which complies to local electrical codes for 1 amp load. No. 18 cable is usually sufficient.
- Assemble plastic bushing into the hole on the coverplate.
- Measure and cut tube assembly to appropriate length so that the bushing will fit under the metal flush valve cover and the free end will protrude into the box through the coverplate by 1/2" minimum. Rotate cover gasket, if necessary, so that the U-shaped wire guides align with the rear opening in valve cover.
- Assemble flush valve to fixture. When ready, remove metal cover and feed the wires from the hardwire converter through the tube assembly and the tube assembly through the bushing on the coverplate.
- Attach the converter wires to the 24 VAC wires from a step down transformer.
- With power to the flushometer, you will see an ascending and descending light sequence to signify that the valve is now in operation mode.
- Assemble coverplate using the bracket and screws provided.
- With the tube bushing located in position, assemble metal cover to flush valve body with tube assembly located in metal cover cut-out.

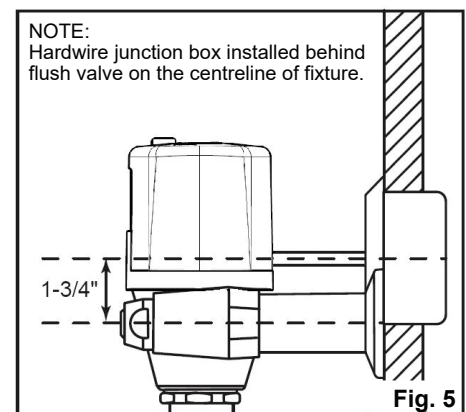

Fig. 5

Step 4:

- Open inlet stop.

INSTALLATION INSTRUCTIONS - HARDWIRED FLUSHOMETER (cont'd)

Step 5: Operation Mode

Upon power up - a sequence of descending and ascending red lights will signify that the valve is in operation mode. Once in operation mode, if factory settings are preferred, no further action is required and the valve installation is complete.

Factory pre-set functions are:

WC bowl length of 24", 24 hour flush is off, Dual Flush feature on.

MAKING ADJUSTMENTS TO THE ELECTRONIC FEATURES

(Optional: Only required if factory settings are not preferred)

Once in operation mode, if adjustments are preferred, installer must move into set up mode.

If desired adjustments are not made within 30 minutes of initial power-up, the power must be disconnected for 10 seconds and then reconnected to obtain another adjustment period.

Step 6: Set-Up Mode

- If 30 minutes have passed since the initial power-up of the valve - open up the battery compartment (Figures 9 and 10) and disconnect the battery snap for 10 seconds. Reconnect and replace the cover and screws. If hardwired - disconnect battery snap to the hardwire converter for 10 seconds.
- To move from operation mode into set-up mode, push and hold electronic override button for five seconds. Release the electronic override button when a solid blue light is visible.
- The watercloset flushometer models have 3 settings which are adjustable via the Set-Up Mode - Bowl Length Selection, Dual Flush Adjustment and 24 Hour Flush Adjustment.
- While in Set-Up Mode, the user will move through the different adjustment modes one by one, in the order as described above. Use the electronic override button to toggle through the different settings of the adjustment feature being altered. To advance to the next adjustment mode, hold down the electronic override button until blue light is present, then release the button. See Figure 6.

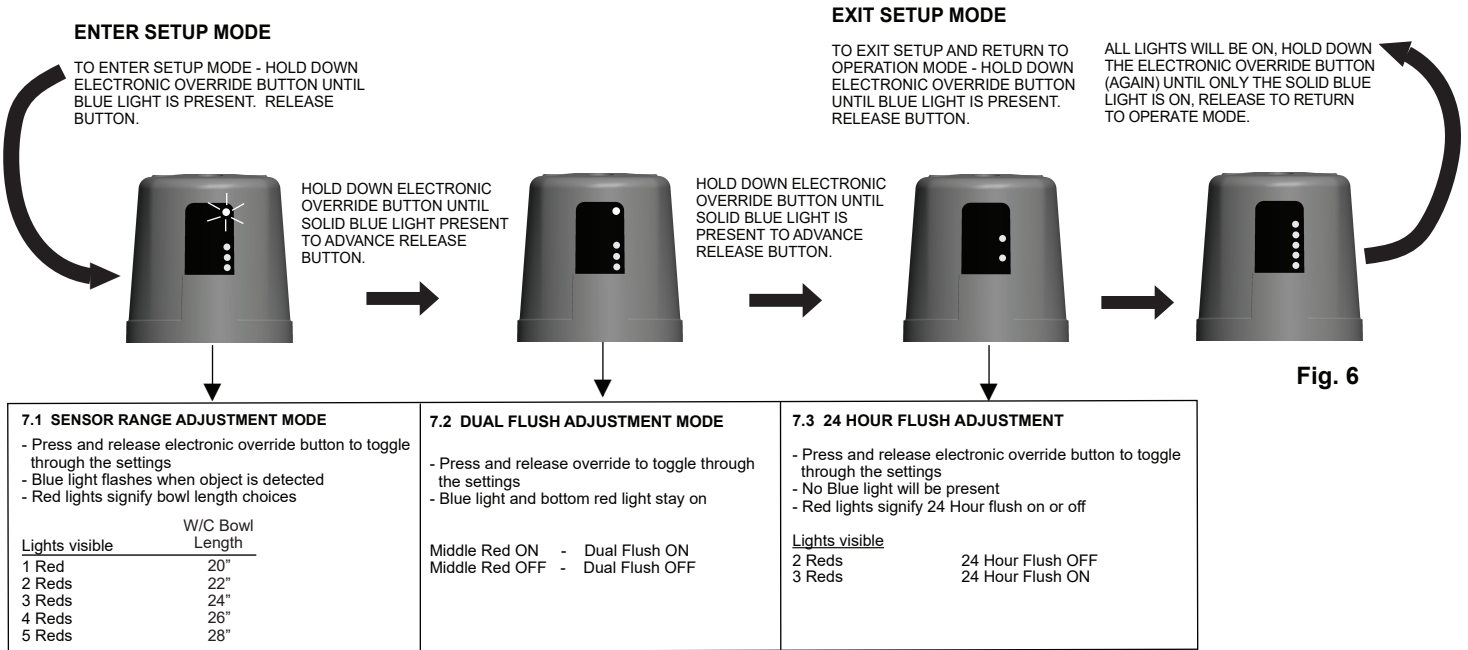

Step 7: Making Adjustments (Optional: Only required if factory settings are not preferred)

7.1 Bowl Length Selection:

- Configure the sensing range by selecting the appropriate bowl length. Refer to Figure 6 for the different bowl length settings.
- The bowl length is the distance from the centre line of the valve to the lip of the bowl (see Figure 7).
- To ensure the correct distance is selected, stand or place a target at the end of the bowl. Starting with one illuminated red light, step through the distances until the blue light begins to flash.
- The flashing light confirms that the sensor is configured for that bowl length.
- NOTE the bowl length setting is **NOT** the sensing range. The Advanced sensor activated flush system uses multiple detection distances and the bowl length to react appropriately to different usage patterns.
- If no further length adjustments are desired, advance to Dual Flush Adjustment mode.
- To advance to Dual Flush Adjustment mode, press and hold down electronic override button for 5 seconds until the solid blue light is present.
- Release electronic override button.

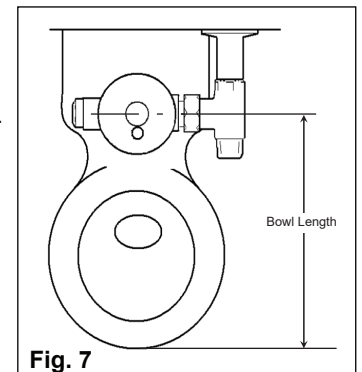

MAKING ADJUSTMENTS TO THE ELECTRONIC FEATURES (cont'd)

(Optional: Only required if factory settings are not preferred)

Step 7: Making Adjustments (Optional: Only required if factory settings are not preferred) - (cont'd)

7.2 Dual Flush Adjustment Mode:

- When dual flush is activated, it provides an average 30% water reduced flush when users do not sit, or are sitting for less than 90 seconds. Pressing the electronic override button while dual flush mode is ON will produce a full flush.
- **To turn Dual Flush Mode ON** - while in dual flush adjustment mode, press the electronic override button so that the middle red light is on.
- **To turn Dual Flush Mode OFF** - while in dual flush configuration, press the electronic override button and turn off the middle light, leaving the other 2 lights on.
- The Advanced Sensor Activated flush system will select flush zones based on the previously selected bowl length.
- To advance to 24 Hour Flush Adjustment Mode, press and hold down the electronic override button for 5 seconds until solid blue light is present.
- Release electronic override button.

7.3 24 Hour Flush Adjustment Mode:

- When the 2 red lights are present - 24 hour flush is OFF.
- When the 3 red lights are present - 24 hour flush is ON.
- Press electronic override button to toggle between ON and OFF mode.
- To return to Operation Mode, press and hold down the electronic override button for 5 seconds until solid blue light is present.
- Release electronic override button.

Exiting Set-Up Mode:

- Can be accomplished in one of two ways;
 1. During the 24 Hour Adjustment feature, press and hold down the electronic override button for 5 seconds until solid blue light is present. Release electronic override button.
 2. During all modes, valve will revert back to operation mode automatically if the electronic override button is not pressed within 2 minutes.

* After the last adjustment has been completed and the flush valve has returned to operation mode, there is a window of approximately 30 minutes where additional changes can be made. If desired adjustments are not made within 30 minutes, the batteries must be disconnected for 10 seconds and then re-connected to obtain another adjustment period. To make changes, begin at step #6 above.

BATTERY STRENGTH INDICATOR & BATTERY REPLACEMENT

TO CHECK BATTERY STRENGTH:

1. During Operation Mode - press and hold down the electronic override button for approximately 10 seconds.
2. DO NOT RELEASE BUTTON WHEN SOLID BLUE LIGHT IS PRESENT - KEEP HOLDING DOWN.
3. After 10 seconds, the battery strength will be displayed via the red lights. The more lights that are present, the more life the batteries have. See Figure 8.
4. When you are satisfied with the strength indication, release the electronic override button to return to Operation mode.

BATTERY STRENGTH INDICATION

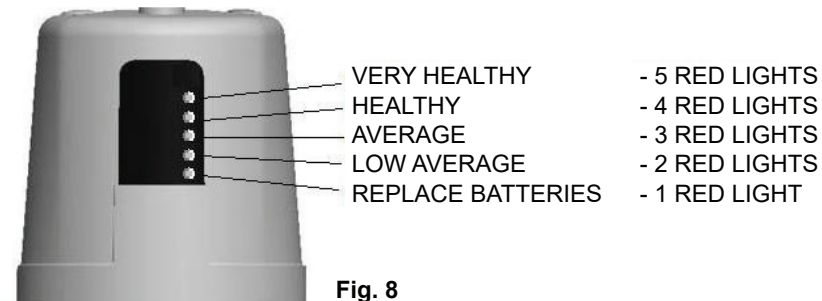

Fig. 8



TO REPLACE BATTERIES:

1. Remove the two cover screws and lift off metal cover, see Figure 9.
2. Hold case/cover securely with one hand and open hinged lid of the battery compartment in the back of the unit.
3. Pull the battery holder out and insert new set of four "AA" batteries into battery holder. (Use the +/- signs on the batteries and the +/- signs on the battery holder for correct positioning.) **Note:** Do not use a metal screwdriver to remove snap from battery holder.
4. Install the refreshed battery holder back into the electronic housing. (When the new batteries are installed and connected, an initial ascending and descending red light sequence will occur.)
5. Close the battery compartment lid ensuring wires are neatly tucked into compartment and are not pinched between the case and cover. Test the electronic override button. Blue light flashes once when override is activated.
6. Place the metal cover back onto flushometer and replace the two cover screws. DO NOT OVERTIGHTEN. Flushometer is now ready for use.

* **NOTE:** All previously adjusted settings will be retained when batteries are changed.

1. **Start-Up:** When batteries are first inserted, there is an initial ascending and descending red light sequence that will occur.
2. **Electronic Override Button in Operating Mode:** Blue light flashes once when electronic override button is activated.
3. **Low Battery Level Indicator:** One RED light flashes every 15 seconds, indicating approximately 5,000 flushes remain from when RED light first started flashing.

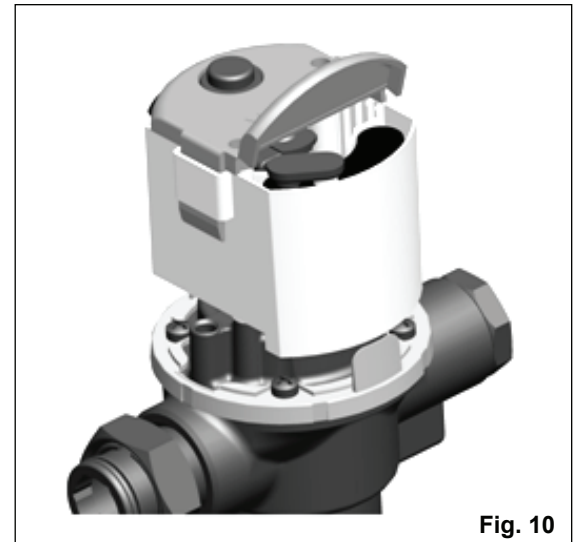

CLEANING INSTRUCTIONS:

CLEAN the outside of the chrome plated flushometer with a damp cloth.

CAUTION: MOST Tub & Tile fixture cleaners contain ACIDS. DO NOT WIPE the cloth used to clean ceramic fixtures over the flushometer as it will remove the chrome plating and leave a discoloured surface.

PROBLEM SOLVING & MAINTENANCE SUGGESTIONS:

NO LIGHTS - NO POWER

Check that the 4 "AA" batteries are positioned properly in the battery holder. Use the +/- signs on the batteries and the +/- signs on the battery holder for correct positioning.
If the batteries are positioned correctly, but there are still no lights, replace with 4 new "AA" Alkaline batteries (see Battery Replacement on page 6).

NOTE: DO NOT USE EXCESSIVE FORCE to close the inlet stop stem. We RECOMMEND that the flushometer be flushed while closing the inlet stop. The noise created by the water flow or the flow into the fixture will stop when the inlet water is shut off.

NOTE: Always use DELTA COMMERCIAL GENUINE PARTS to maintain the warranty.

EXCESSIVE NOISE:

1. PARTIALLY close the inlet stop.
2. Pressures OVER 75 PSI may lead to an increase in NOISE, water could SPLASH out of the fixture more easily and the LIFE of any plumbing valve may be SHORTENED.
3. INSTALL a Pressure Reducing Valve set at a lower pressure if actual pressure is over 75 PSI. While the TECK Flushometer will operate up to 125 PSI, the preferred operating range is between 35 to 65 PSI.
4. On flushometers that have been installed for a number of years, check the Renewable Seat (062007A, item #11) for wear and replace if necessary.

EXCESSIVE WATER FLOW RATE:

1. OPEN inlet stop ONE TURN and adjust Regulating Screw (061024A, item #7) to the fixture requirement.
2. Operation of flushometer with inlet stop BELOW ONE TURN OPEN may cause EXCESSIVE NOISE. The lowest open setting for the inlet stop may vary dependent on the installation.

SHORTAGE OF WATER TO PROPERLY FLUSH BOWL:

1. OPEN inlet stop fully.
2. CHECK pipeline for size or obstruction, partially closed gate or other supply line valve, corroded or undersize water piping.
3. CHECK water pressure.
4. Water flow rate is determined by BOTH the water pipe size AND the water pressure available.
5. A water closet flush valve requires a minimum water supply of 1" (or larger), depending on a number of different factors including water pressure (PSI) available, pipe size and length of pipe run, number of fixtures per washroom and per building, fixture type, fixture usage factor, elevation of valve above the water main, etc. We strongly recommend that pipe size calculations be done to insure proper water supply sizes.

Flushometers do NOT provide a water supply; they are merely automatically timed self-closing valves. The inlet supply piping is the water reservoir that must supply sufficient water volume in a short period of time (4 to 10 seconds) to properly flush and clear the fixture.

CONTINUOUS FLUSHING:

1. The Regulating Screw (061024A, item #7) may be turned RIGHT (clockwise) TOO FAR. Adjust by slowly turning the Regulating Screw LEFT (counter-clockwise).
2. If flush is still continous, close inlet stop, remove Regulating Screw (061024A, item #7), CLEAN bypass slot in the Screw, REPLACE it in the valve and ADJUST slowly for proper flush.
3. Remove cast cap assembly and Diaphragm/Guide Assembly (061323A, item #10), check for contaminants at renewable seat and diaphragm and check for debris in the cap for blockage. Also CHECK that the Diaphragm/Guide slides easily in the Renewable Seat.

VALVE WILL NOT FLUSH:

1. When the valve has been taken apart for servicing and re-assembled and does NOT operate, check that the Cast Cap has been put on the body properly. The Regulating Screw (061024A, item #7) should always be on the same side as the inlet stop.
2. When all lights operate as expected but valve will not flush, check that the solenoid makes a clicking sound. If no clicking sound is present, then replace with Electronic Repair Kit (061142A, item #19 or 061144A, item #20).
3. After a number of years, the valve will flush but shuts off immediately when activated. The Diaphragm (060079A-MMO, item #10) is worn or split and needs replacing.

SLIGHT WATER LEAK INTO FIXTURE:

1. EXAMINE the seating surface of the Diaphragm (060079A-MMO, item #10) for imbedded sediment.

6L ADJUSTABLE -DF MODELS ONLY

EXCESSIVE WATER DURING FULL FLUSH

1. Partially CLOSE inlet stop until full flush volume is reduced to the desired amount.

SHORTAGE OF WATER DURING REDUCED FLUSH

1. Lower regulating screw (061024A, item #7) by turning clockwise until reduced flush volume is sufficient. Only a small adjustment of the regulating screw is required. Note: Lowering regulating screw too far may result in continuous flushing.

Fig. 11

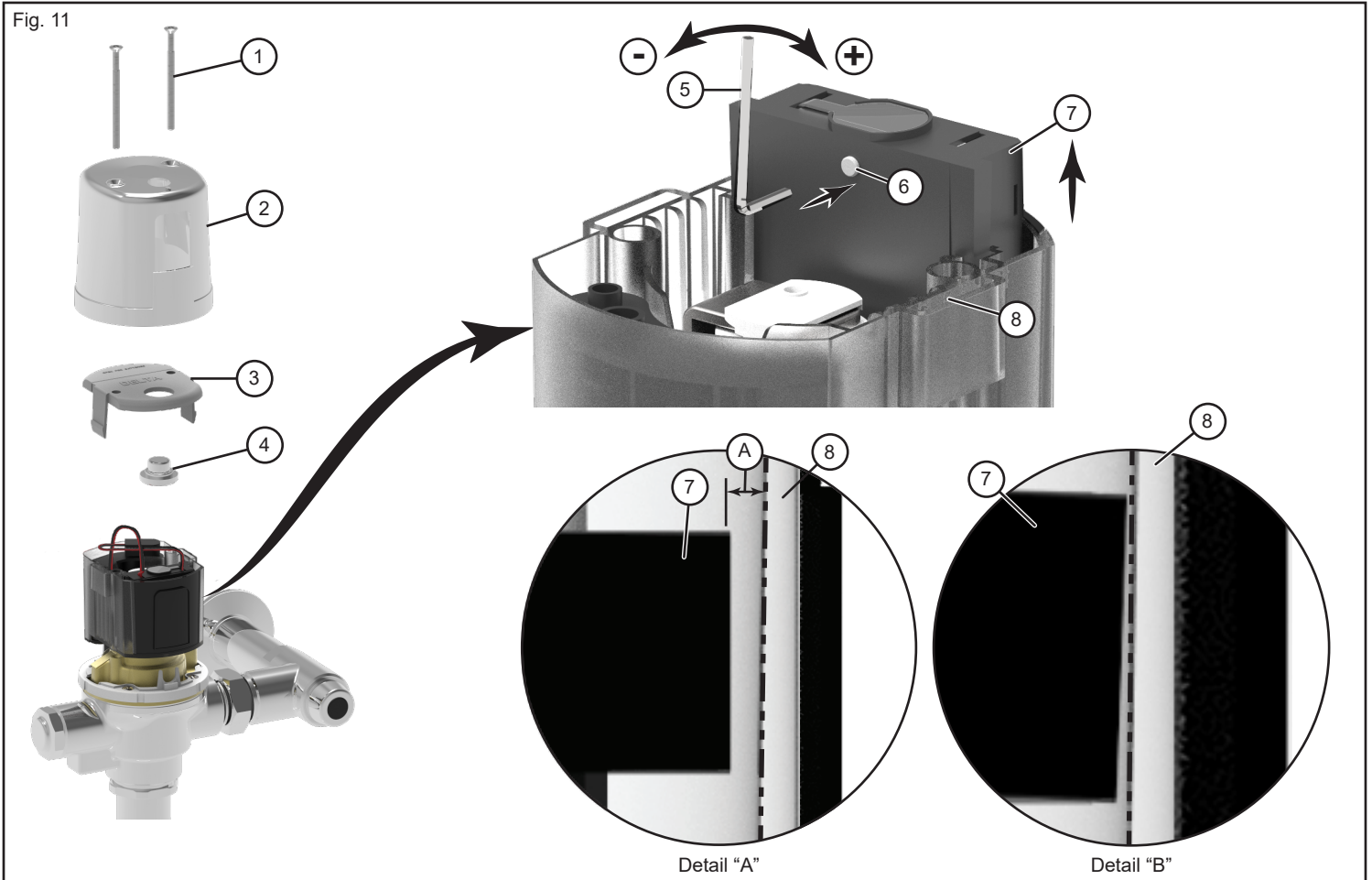

INADVERTENT FLUSHING (see Figure 11)

1. Check for the presence of a mirror or reflective surface across from the flushometer.
2. Cover the reflective surface by standing in front or with paper, if this resolves the inadvertent flushing then:
3. Follow the instructions "Making Adjustments to the Electronic Features" on page 4, to reduce the sensor range until inadvertent flushing is resolved. If this does not resolve the inadvertent flushing proceed to step 4.
4. Remove the two cover screws (1), metal cover (2), cap (3) and electronic override button (4).
5. Raise the board (7) up out of the box to get access to the adjustment screw (6).
6. Using a 1/16" hex key (5) turn the adjustment screw (6) located on the top of the board (7). Turn the screw counter-clockwise \ominus to decrease the angle (A) or clockwise \oplus to increase the angle, see "Detail A".

CAUTION: DO NOT let the board (7) touch the plastic housing (8), as shown in "Detail B". Maximum screw rotation is approximately 2-1/2 turns.

7. If the cover of the board becomes detached, rotate the screw clockwise until it can be reattached and repeat step 6, taking care to ensure you do not over adjust the screw

Delta® Commercial Faucet Limited Warranty

All parts of Delta® HDF® and TECK® faucets are warranted to the original commercial purchaser to be free from defects in material, finish and workmanship for a period of five (5) years unless otherwise specifically stated in the catalogue and price book. This warranty is made to the original commercial purchaser and shall be effective from date of purchase as shown on the purchaser's receipt.

Delta Faucet will, at its option, repair or replace, FREE OF CHARGE, during the warranty period, any part which proves defective in material or workmanship under normal installation, use and water and service conditions. If Delta Faucet concludes that the returned part was manufactured by Delta Faucet and is, in fact, defective, then Delta Faucet will honor the warranty stated herein. Replacement parts can be obtained from your local dealer or distributor listed in the telephone directory or by returning the part along with the purchaser's receipt to our factory, TRANSPORTATION CHARGES PREPAID, at the address listed. THIS WARRANTY IS THE ONLY EXPRESS WARRANTY MADE BY DELTA FAUCET. ANY CLAIMS MADE UNDER THIS WARRANTY MUST BE MADE DURING THE FIVE-YEAR PERIOD REFERRED TO ABOVE. ANY IMPLIED WARRANTIES, INCLUDING THE IMPLIED WARRANTY OF MERCHANTABILITY OF FITNESS FOR A PARTICULAR PURPOSE, ARE LIMITED IN DURATION TO THE DURATION OF THIS WARRANTY. LABOUR CHARGES AND/OR DAMAGE INCURRED IN INSTALLATION, REPAIR OR REPLACEMENT AS WELL AS INCIDENTAL AND CONSEQUENTIAL, SPECIAL, INDIRECT OR PUNITIVE DAMAGES CONNECTED THEREWITH ARE EXCLUDED AND WILL NOT BE PAID BY DELTA FAUCET.

Some states/provinces do not allow limitations on how long an implied warranty lasts, or the exclusion or limitation of incidental or consequential damages, so the above limitations or exclusions may not apply to you. This warranty gives you specific legal rights, and you may also have other rights which vary from state/province to state/province.

This warranty is for commercial products only from Delta Faucet Company and Delta Faucet Canada (a division of Masco Canada Limited) and is void for any damage to this faucet due to misuse, abuse, neglect, accident, improper installation, or any use in violation of instructions furnished by Delta Faucet.

This device complies with Part 15 of the FCC Rules. Operation is subject to the following two conditions:

- (1) this device may not cause harmful interference, and
- (2) this device must accept any interference received, including interference that may cause undesired operation.

Note: This equipment has been tested and found to comply with the limits for a Class A digital device, pursuant to Part 15 of the FCC Rules. These limits are designed to provide reasonable protection against harmful interference when the equipment is operated in a commercial environment. This equipment generates, uses, and can radiate radio frequency energy and, if not installed and used in accordance with the instruction manual, may cause harmful interference to radio communications. Operation of this equipment in a residential area is likely to cause harmful interference in which case the user will be required to correct the interference at his own expense.

Warning: Changes or modifications not expressly approved by Delta could void the user's authority to operate the equipment.

CAN ICES-3 (A) / NMB-3(A)

© 2017 Masco Canada Ltd.

For further technical assistance, call Delta Commercial Technical Service at **1-800-387-8277** (Canada) or **1-877-509-2680** (U.S.A.).

Delta Faucet Canada, a division of Masco Canada Limited
350 South Edgeware Road, St. Thomas, Ontario, N5P 4L1
1-800-567-3300 (English) 1-800-265-9245 (French)

Delta Faucet Company
Box 40980, 55 East 111th St., Indianapolis, IN, U.S.A. 46280
(317) 848-1812

www.deltacommercialfaucets.com

specselect
.com