



# 150 T4

Write purchase model number here for future reference

212193

212193

212193

212193

**NOTE:** Control Box #0 and #1 are designed for routine 171°F (77°C) disinfection cycles up to 30 minutes. Control Box #8 is not recommended for high temperature disinfection cycles as the thermostatic mixing valve limits the higher temperature flow output.

**NOTE:** For optimum performance of this product, we recommend a system pressure between 20 and 80 PSI static. This product will operate up to a maximum of 125 PSI static per ANSI and CSA requirements. However, we do not recommend pressure above 80 PSI. Thermal expansion or leaking pressure reducing valves may require use of expansion tanks or relief valves to ensure your system never exceeds its maximum intended pressure setting.



Fig. 1

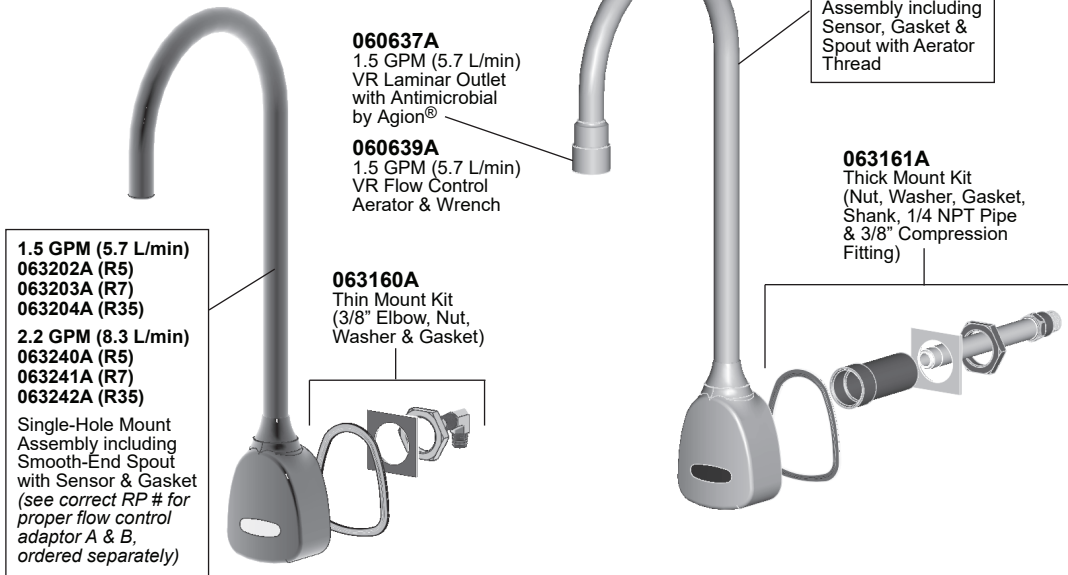

- 1.5 GPM (5.7 L/min)
- 063202A (R5)
- 063203A (R7)
- 063204A (R35)
- 2.2 GPM (8.3 L/min)
- 063240A (R5)
- 063241A (R7)
- 063242A (R35)

Single-Hole Mount Assembly including Smooth-End Spout with Sensor & Gasket (see correct RP # for proper flow control adaptor A & B, ordered separately)

- 060637A  
1.5 GPM (5.7 L/min)  
VR Laminar Outlet with Antimicrobial by Agion®
- 060639A  
1.5 GPM (5.7 L/min)  
VR Flow Control Aerator & Wrench

- 063160A  
Thin Mount Kit (3/8" Elbow, Nut, Washer & Gasket)

- 063207A (R5)
  - 063208A (R7)
  - 063209A (R35)
- Single-Hole Mount Assembly including Sensor, Gasket & Spout with Aerator Thread

- 063161A  
Thick Mount Kit (Nut, Washer, Gasket, Shank, 1/4 NPT Pipe & 3/8" Compression Fitting)

212193

212193

212193

212193

## OPTION LIST

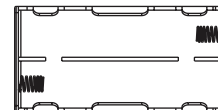

- 060681A  
Battery Holder

## TRANSFORMERS

- 060704A  
Transformer 110 to 24 VAC 20VA up to 5 Electronic Valves
- 060771A  
Transformer 110 to 24 VAC 40VA up to 10 Electronic Valves

- A** 063163A  
1.5 GPM (5.7 L/min)
- 063243A  
2.2 GPM (8.3 L/min)  
Bushing with Flow Control (to be used with Control Box #'s 1 & 8)

- B** #7 Smooth End Spouts only

- 063162A  
1.5 GPM (5.7 L/min)
- 063244A  
2.2 GPM (8.3L/min)  
Adaptor with Flow Control (to be used with Control Box #0)

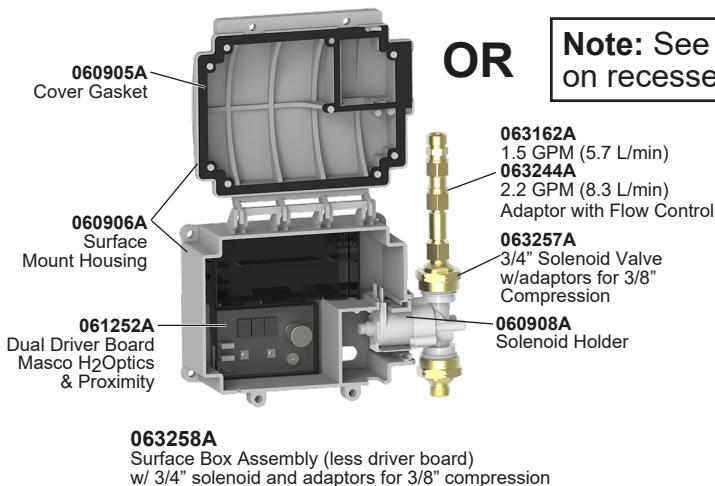

**OR** Note: See page 3 for parts breakdown on recessed mount boxes.

- 063162A  
1.5 GPM (5.7 L/min)
- 063244A  
2.2 GPM (8.3 L/min)  
Adaptor with Flow Control
- 063257A  
3/4" Solenoid Valve w/adaptors for 3/8" Compression
- 060908A  
Solenoid Holder

- 061256A  
36" Cable Extension
- 060683A  
24VAC to 6VDC Converter
- 062032A  
Braided Polymer Hose

063258A  
Surface Box Assembly (less driver board) w/ 3/4" solenoid and adaptors for 3/8" compression

\*Package Quantities May Change.  
Check the Parts section of the latest Delta Commercial Faucet Price List for current quantities.

**PLEASE LEAVE this M&I Sheet with the owner, maintenance plumber, etc. as items relating to ongoing maintenance suggestions and procedures are included.**

Installation should be in accordance with local plumbing and electrical codes.  
**FLUSH ALL PIPES THOROUGHLY BEFORE INSTALLATION.**

## INSTALLATION AND SET UP INSTRUCTIONS

### FOR SURFACE MOUNT HOUSING: CONTROL BOX #0

#### STEP 1. FAUCET INSTALLATION

Depending on the installation, use the 063160A thin wall kit OR 063161A thick wall kit (both provided as standard). Connect 20" braided hose to spout inlet. Clean surface where faucet will be mounted. Install faucet to sink/wall using nut and washer provided. Ensure gasket is centered on faucet prior to tightening. Do not overtighten the nut or reposition the faucet once installed, otherwise damage to the gasket may result. Cutting or trimming of the gasket is not recommended. If the gasket is trimmed or modified, then clear silicone sealant should be used between the faucet and sink/wall surface to prevent water leakage.

#### STEP 2. BATTERY BOX INSTALLATION

Mount battery box to wall under sink using the 4 supplied screws and anchors. Use 1/4" drill for wall anchors. **Be sure to install the box within the dimensions provided so the hose and spout cable will reach connections at faucet and battery box. Refer to illustration (Fig. 2).**

#### STEP 3. FLUSH SYSTEM

To flush supply line, assemble these components as shown (Fig. 3) and run water for 1 minute. Shut off water supply. Attach aerator or flow control with adapter for #7 smooth end spouts. **NOTE:** Do not connect supply to the solenoid inlet until line is flushed directly out spout.

#### STEP 4. CONNECT WATER SUPPLY

Disassemble the components, reassemble the ones shown here (Fig. 4) supply line and adaptor to the bottom fitting on box, braided hose to the top fitting on box. Turn on water supply. **DO NOT SOLDER CONNECTIONS!**

#### STEP 5. POWER UP

Unscrew the battery box lid screws (2). Install 4 "Alkaline C" batteries in holder or snap the battery clip directly to the optional 24 VAC converter.

**⚠ BATTERY VERSION** Install four "Alkaline C" batteries provided into the battery holder. After the batteries are installed, make the sensor connection on the driver board neatly inside the battery box. Connect battery clip to battery pack. Two beeps indicate product is ready to use. Use caution not to damage wires or components on electronic driver board. See Fig. 5. Secure lid using screws. Do not use 9V battery.

**⚠ HARDWARE VERSION** Install CSA and/or UL approved Class 2 transformer or equivalent in a convenient location or in a pipe chase. **(Do NOT install the transformer inside the control box.)** With the power off, bring the 24 VAC supply wires to the box. Connect the 24 VAC supply to the 060683A conversion kit. Connect the battery snap of the hardwire converter to the driver board battery clip. Ensure snap does not touch anyconductive metal surface, then make the sensor connection on the control module neatly inside the battery box. Do not remove battery snap from hardwire converter by using a flat screwdriver, damage may result. Turn on power supply for the transformer.

#### STEP 6. PREPARE SINK AREA

Before connecting the spout cable – clean off counter and remove all objects from the sink.

#### STEP 7. TIE SPOUT CABLE

Attach spout cable to box connector. Use tie wraps to secure spout cable to spout hose. Your faucet is now ready for use (Fig. 2).

#### STEP 8. TEST FOR OPERATION

Test for operation. If faucet leaks from spout outlet: SHUT OFF WATER SUPPLIES. Replace solenoid (2).

If faucet exhibits very low flow: A) Remove and clean spray outlet, or B) SHUT OFF WATER SUPPLY. Clean or replace screen assembly (2). If unit does not work properly; see Troubleshooting Guide on page 7.

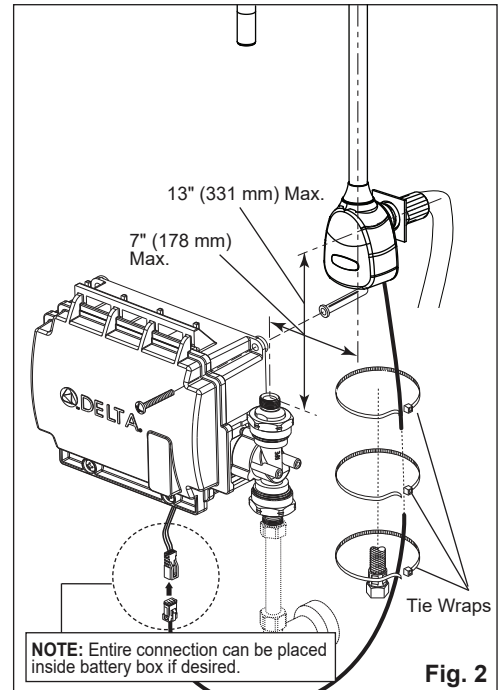

Fig. 2

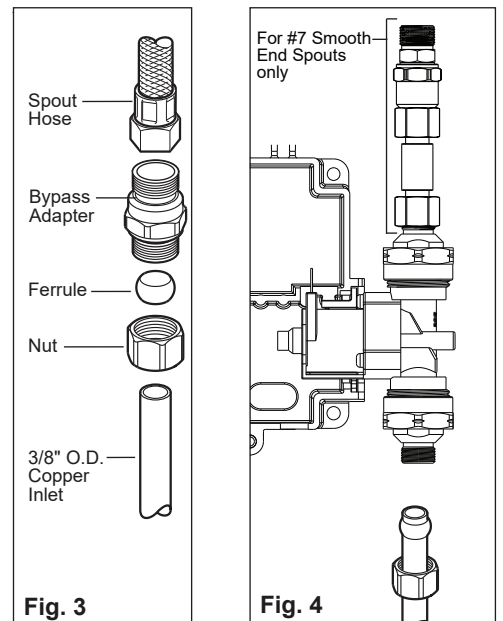

Fig. 3

Fig. 4

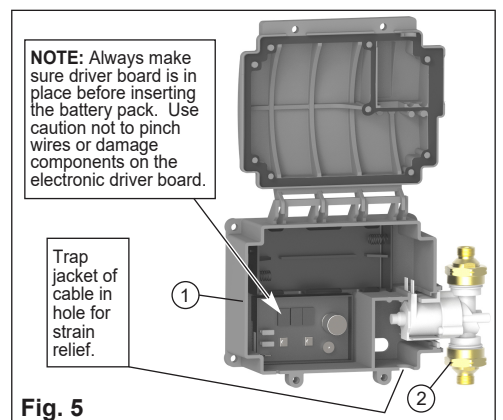

Fig. 5

Installation should be in accordance with local plumbing and electrical codes.  
**FLUSH ALL PIPES THOROUGHLY BEFORE INSTALLATION.**

## INSTALLATION AND SET UP INSTRUCTIONS

### FOR RECESS MOUNT HOUSING: CONTROL BOXES #1 & 8

#### STEP 1. ROUGH IN

**Note:** Wires connecting between box(es) and from transformer must be protected from abrasion, and being pulled at connections. They also may have to be fished through at a later stage of construction. Depending on installation, the cable bushings included may be replaced by **installer supplied** 1/2" conduit. Rough-in box as per Figure 8.

The transformer is to be installed in an adjacent accessible space. **(Do NOT install the transformer inside the control box.)** Cable from the transformer to the driver board/controller may be roughed in at this time depending on installation. Use cable which complies to local electrical codes for a 1 amp load.

**HARDWIRE OR BATTERY:** If recessed box is supplied, rough in as per Figure 8. The most vandal resistant installation is when the control box is as close to the bottom of the sink as feasible. For wall hung sink installation, sensor conduit rough in should be directly under the basin to minimize sensor cord exposure. Rough in drainage. Rough in water supply to 10" control box inlets and to spout connection. Finish walls.

Valve spacer is for temporary use only for flushing of system. Must be replaced with solenoid valve and washers (Fig. 6 & 7).

#### STEP 2. FAUCET INSTALLATION

Depending on the installation, use 063160A thin wall kit OR 063161A thick wall kit (both provided as standard). Clean surface where faucet will be mounted. Install faucet to sink/wall using nut and washer provided. Ensure gasket is centered on faucet prior to tightening. Do not over-tighten the nut or reposition the faucet once installed, otherwise damage to the gasket may result. Cutting or trimming of the gasket is not recommended. If the gasket is trimmed or modified, then clear silicone sealant should be used between the faucet and sink/wall surface to prevent water leakage.

**NOTE: If the gasket is trimmed or not installed, then use clear silicone sealant between the faucet and lavatory to prevent water from leaking beneath lavatory.**

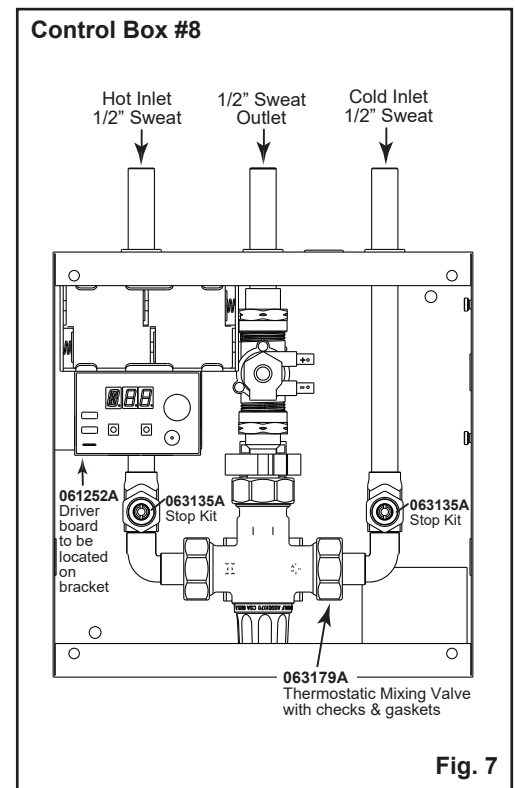
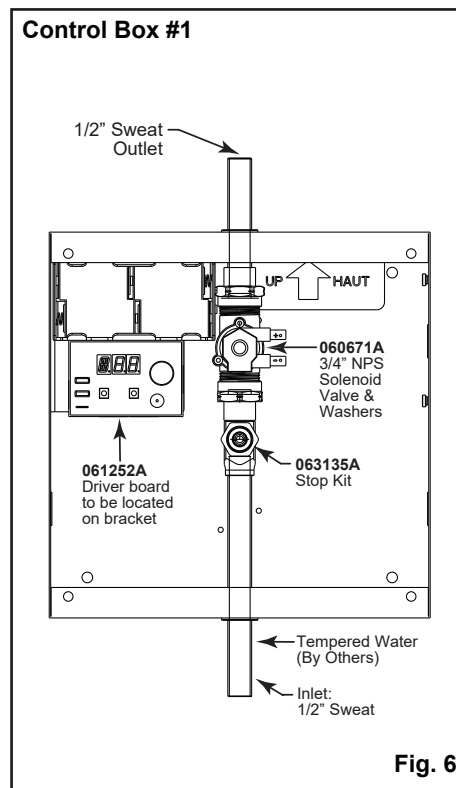

#### COVERS

**060577A**  
12" Stainless Steel Cover

**060073A**  
Screws (4/pkg) and driver bit for covers

#### TMV Repair Kits

**061137A**  
Adjustment Wrench

**063164A**  
Check Valves (2/pkg)

# INSTALLATION AND SET UP INSTRUCTIONS

## FOR RECESS MOUNT HOUSING: CONTROL BOXES #1 & 8

### STEP 3. CONNECT WATER SUPPLY

Install sink and connect drainage to rough in. See applicable Fig. 6 or Fig. 7. Please note that the connection and fittings are supplied by the installer to connect 1/2" nominal sweat at the box outlet and 3/8" compression at the spout. Connect water supply through to spout. Assure supply lines are completely flushed and free of debris.

### STEP 4. FLUSH SYSTEM/SET TEMPERATURE

Remove coverplate from control box. Open screwdriver stop(s) to flush installation for **1 minute minimum**.

- 4A** Run water for a sufficient time so the hot and cold water supplies are as hot and cold as they will get.
- 4B** Place a thermometer in a plastic container and hold in the water stream. Record the temperature reading and note position of temperature control, and lock at desired setting.
- 4C** **Thermostatic Mixing Valve** (Fig. 7) To adjust the mixed outlet temperature of the valve, remove the cap to gain access to the adjusting spindle. The spindle should be rotated towards the "C" side to reduce the temperature and towards the "H" side to increase the temperature - until the desired set point is reached (refer to Fig. 9).

**Periodic Inspection/Maintenance** - We recommend that this valve is checked at least once per year to ensure its continued function. For installations with poor or unknown water quality, or other adverse supply conditions, it may be necessary to check the valve at more frequent intervals. The temperature should be checked at the same outlet as was used for commissioning in the first instance. If the temperature is more than 3°F from the commissioning in temperature, refer to the included Cash Acme Maintenance and Installation Guide.

- 4D** Close stop(s).

### STEP 5. CONNECT ELECTRICAL SUPPLY, SOLENOID VALVE AND SENSOR

Remove plastic threaded spacer nipple and install solenoid valve with body arrow in the direction of water flow. Install flow control for #7 smooth end spouts. See Fig. 10. Feed sensor wire from spout into control box and then connect to the driver board. Connect red solenoid wire from the driver board to "+" marked solenoid terminal on solenoid valve, black solenoid wire to other solenoid terminal.

**BATTERY VERSION** Install four "Alkaline C" batteries provided into the battery holder. Connect battery clip from the driver board to battery pack. Ensure snap does not touch any conductive metal surface. Two beeps indicate power is ready for use. Use caution not to damage wires or components on electronic driver board. Secure cover using screws. Do not use 9V battery.

**HARDWARE VERSION** Install CSA and/or UL approved Class 2 transformer or equivalent in a convenient location or in a pipe chase. **(Do NOT install the transformer inside the control box.)** With the power off, bring the 24 VAC supply wires into the box. Connect the 24 VAC supply to the 060683A conversion kit. Connect the battery snap of the hardwire converter to the driver board battery clip. Ensure snap does not touch any conductive metal surface. Do not remove battery snap from hardwire converter by using a flat screwdriver, damage may result. Turn on power supply for the transformer. Secure cover using screws.

### STEP 6. SERVICES

Open screwdriver stop(s). Flush line. Install aerator, if applicable.

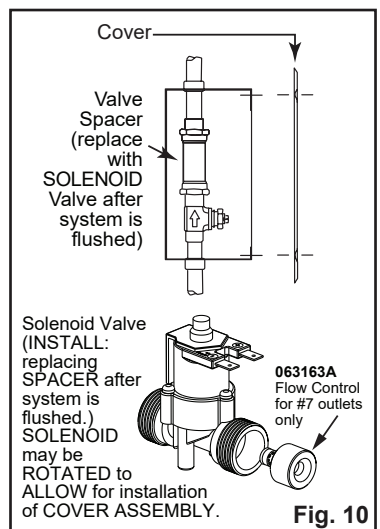
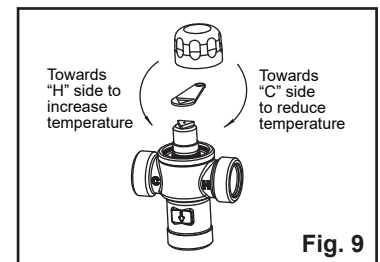
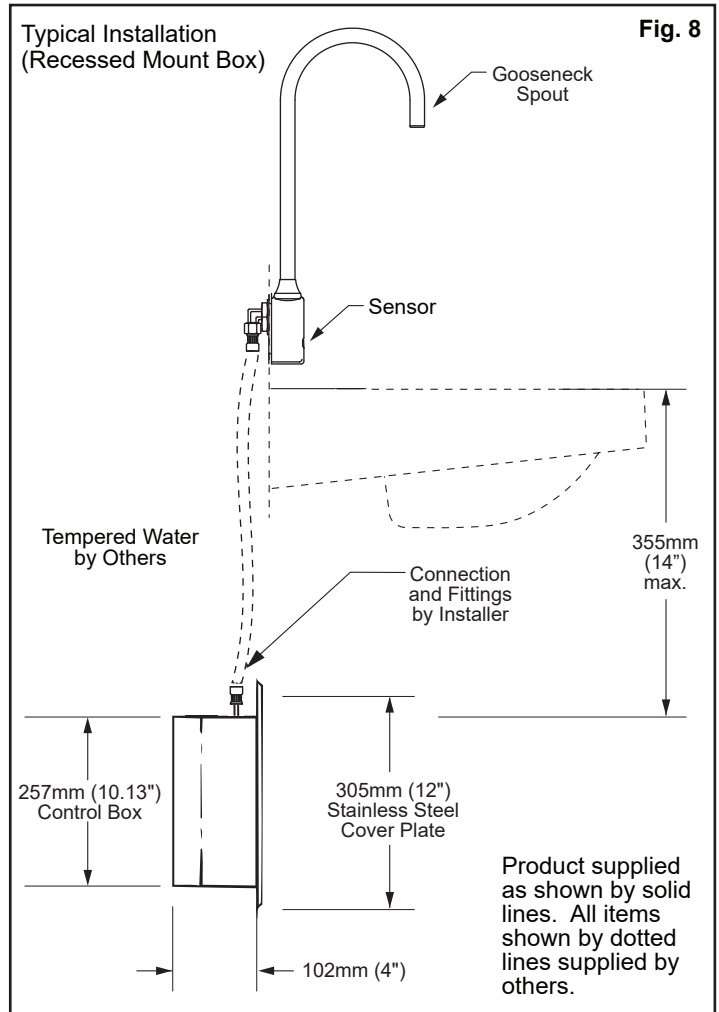

# INSTALLATION AND SET UP INSTRUCTIONS

## FOR RECESS MOUNT HOUSING: CONTROL BOXES #1 & 8

### STEP 7. TEST FOR OPERATION

Test for operation. If unit does not work properly, see Troubleshooting Guide on page 7.

### STEP 8. MAKING ADJUSTMENTS

If adjustments are required. Note factory defaults for program shown in Quick Reference Chart. Otherwise, replace the driver board housing cover as the electronic product is ready for use.

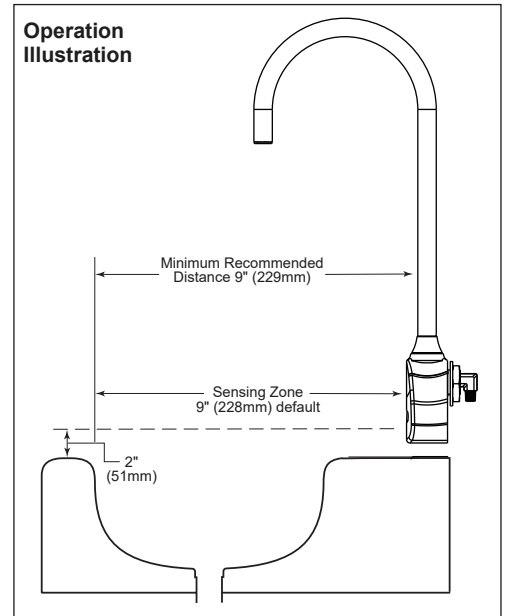

## DRIVER BOARD QUICK REFERENCE CHART

Symbol	Function	Description	Factory Default Setting	Function Settings
d	Sensor Range	You can set the distance at which the sensor will detect hands in the wash area.	9" from sensor	3" to 15" from sensor
T	Auto Timer (faucet shut-off)	A safety mode in the event the sensor continually sees a target.	45 seconds	5, 7, 10, 12, 15, 30, 45, 60, 75, 90 seconds 2.0, 4.0, 6.0, 8.0, 9.9 minutes
R	Rinse Cycle	If this feature is turned to an "xx" hour value, the faucet will turn on itself after this set time from last use.	- (OFF)	- (OFF), 6, 12, 18, 24, 30, 36, 42, 48 hours
r	Rinse Time	This is the amount of time you want the faucet to stay on to move the water in the line, if the <i>Rinse Cycle</i> is made active.	10 seconds (once enabled)	10, 20, 30, 40, 50, 60, 90 seconds 2.0, 2.5, 3.0 minutes
b	Buzzer	Buzzer will annunciate twice upon power up indicating product is ready to use.	ON	ON, - (OFF)
L	LED	LED will light up indicating low power.	- (OFF)	ON, - (OFF)
M	Metering Mode	This feature changes the product into a metering faucet; it will run the full set amount of time after the user's hands are first detected.	- (OFF)	-- (OFF), 7, 8, 9, 10, 11, 12, 13, 14, 15, 18, 24, 30, 40, 50, 60, 90 seconds 2.0, 2.5, 3.0, 3.5, 4.0 minutes



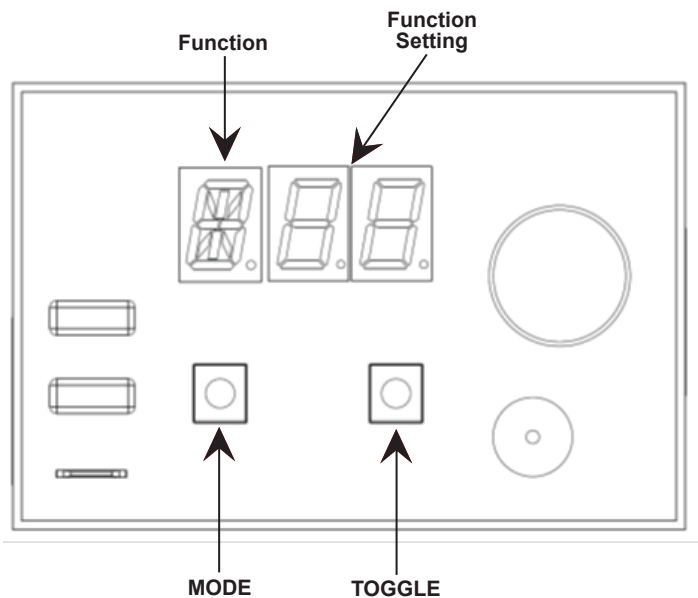

To adjust settings, press and hold MODE (yellow pushbutton on left hand side) until the Function symbol appears. Once in Adjustment Mode, keep pressing MODE until desired Function is reached (see Quick Reference Table). To change Function Setting, press and release TOGGLE (white pushbutton on right hand side) until desired Function Setting is reached (see Quick Reference Table).

**Note:** Will leave Adjustment Mode after 5 seconds.

### SENSOR RANGE (d)

The sensor range is the maximum distance at which the user is detected. The sensor range settings are 3 - 15" in 1" increments. The sensor range default value is 9".

### AUTO TIMER (T)

Auto Timer is a safety mode in the event the sensor continually sees a target (i.e. blocked sensor). In this case, the faucet will stop after the pre-determined time period expires. The Auto Timer values are 5, 7, 10, 12, 15, 30, 45, 60, 75, 90 seconds and 2.0, 4.0, 6.0, 8.0, 9.9 minutes (decimal denotes minutes). The Auto Timer default value is 45 seconds.

### RINSE CYCLE (R)

This feature is meant to purge stagnant water from supply lines. The faucet will turn on after the set amount of hours of inactivity and run the set *Rinse Time (r)* (see below).

### RINSE TIME (r)

This feature is only active if a *Rinse Cycle (R)* time is chosen. The setting determines for how long the faucet will turn on during the *Rinse Cycle (R)*. The rinse time settings are 10, 20, 30, 40, 50, 60, 90 seconds and 2.0, 2.5, 3.0 minutes (decimal denotes minutes).

### BUZZER (b)

The buzzer on the driver board will annunciate twice upon power up indicating product is ready to use. Buzzer options are ON and -(OFF), the default setting is ON.

### LED (L)

The LED on the sensor will blink indicating low power. LED options are ON and -(OFF), the default setting is OFF.

### METERING MODE (M)

This feature changes the product into a metering faucet; it will run the full set amount of time after the user's hands are first detected, and will continue to run after the user removes their hands.

Options are: -(OFF), 7, 8, 9, 10, 11, 12, 13, 14, 15, 18, 24, 30, 40, 50, 60, 90 seconds and 2.0, 2.5, 3.0, 3.5, 4.0 minutes (decimal denotes minutes). The default setting is -(OFF). **Note:** *Auto Timer (T)* is disabled when the feature is turned on.

## BATTERY STRENGTH INDICATOR

To check the battery strength:

Press and hold MODE (yellow pushbutton on left hand side). After 5 seconds the battery strength will be displayed:

- FUL - Healthy
- MID - Average
- Lo\_ - Low Average
- bAd - Replace Batteries (buzzer will annunciate and LED will blink if activated - if these features are turned on).  
Faucet will disable itself if batteries are not replaced.

If you have any questions about the installation of this product or need help troubleshooting this product, please call Delta Commercial Technical Services at **1-800-387-8277** (Canada) or **1-877-509-2680** (U.S.A.).

# CARE INSTRUCTIONS

This Delta Commercial faucet is designed and engineered in accordance with the highest quality and performance standards. With proper care, it will give years of trouble free service. Care should be given to the cleaning of this product. Although the chrome finish is extremely durable, it can be DAMAGED by ACIDIC CLEANERS (i.e. cleaners designed specifically for vitreous china lavatories and water closets), HARSH ABRASIVES or POLISH. To clean, simply wipe the surface with a damp cloth and blot dry with a soft cloth. Avoid directing water spray or cleaners directly at sensor lens.

## TROUBLESHOOTING GUIDE

If the faucet is not working properly, first check for error codes by doing the following:

Press and hold TOGGLE (white pushbutton on right hand side) button for 5 seconds. Once you see the “E”, press TOGGLE button to cycle through and note the error codes:

- E01 - Related to Sensor
- E02 - Related to Sensor
- E03 - Related to Controller
- E05 - Related to Solenoid
- E06 - Related to power (replace batteries)
- E07 - Related to power (replace batteries)

<b>Step 1</b>	Check to ensure faucet was installed according to the M&I sheet.  Test for operation. If unit does not operate:	Note: See attached M&I, pages 1 to 5.  Check lens to be sure it is not blocked with foreign matter. Remove vinyl scratch protector from sensor, if present. Check to be sure power cable is properly secured in fitting. Check to be sure batteries are fresh and properly installed. Check two wires to solenoid to be sure they are connected correctly. Check to be sure water supply is turned on.		
	If faucet shuts off due to interference:	When the faucet detects an object for longer than 45 seconds, it will automatically shut off until the object is removed. Once the object is removed for at least 1 second, the faucet will operate normally.  Sensor blocked by dirt or water.	Clean sensor window.	
<b>Step 2</b>	Faucet makes beeping noise.	<b>BATTERY POWERED</b> Faucet beeps twice and LED blinks when turning off: indicates batteries are low and need to be replaced (1500 cycles or 2 weeks left). <b>Faucet beeps continuously when hands in front of spout, LED blinks and no water.</b> Faucet locked out because batteries are too low.	Replace batteries.  Replace batteries.	
		<b>HARDWIRE</b> Check voltage from converter and transformer. It should be approximately 6.4 volts DC coming from converter to the driver board.	Replace Hard Wire converter 060683A, if required.	
<b>Step 3</b>	The faucet stops working. No water flow. Check the function of the solenoid.	The solenoid should “click” when activated.		
		If there is a clicking sound;	This indicates that both the sensor and the solenoid are functioning.  Ensure inlet screen on solenoid is not plugged with debris.  Check the incoming water supply. Turned on, proper pressure and volume, etc.	Clean as required.  Correct as required.
		If no clicking sound;	Check for a pressure lock between the mixing valve and the solenoid. Turn off the water supply and undo the connection to the inlet of the solenoid, this will eliminate any built up pressure. <b>Then activate sensor and test fire the solenoid.</b>	
		<b>If after above there is no clicking sound;</b> Defective solenoid.	Replace 063257A or 060671A Solenoid.	
<b>Step 4</b>	If faucet does not activate or works erratically;	Check for electrical interference.  Check for interference from other electrical devices within close proximity to the spout or battery box. Devices such as other infrared devices, transformers, etc.	Call Technical Service if any such conditions found.	
<b>Step 5</b>	If after completion of all above steps, the valve still does not function correctly; Call Technical Service for further assistance at 1-800-387-8277 (Canada) or 1-877-509-2680 (U.S.A.).			

## Delta® Commercial Faucet Limited Warranty

All parts of Delta® HDF® and TECK® faucets are warranted to the original commercial purchaser to be free from defects in material, finish and workmanship for a period of five (5) years unless otherwise specifically stated in the catalogue and price book. This warranty is made to the original commercial purchaser and shall be effective from date of purchase as shown on the purchaser's receipt.

Delta Faucet will, at its option, repair or replace, FREE OF CHARGE, during the warranty period, any part which proves defective in material or workmanship under normal installation, use and water and service conditions. If Delta Faucet concludes that the returned part was manufactured by Delta Faucet and is, in fact, defective, then Delta Faucet will honor the warranty stated herein. Replacement parts can be obtained from your local dealer or distributor listed in the telephone directory or by returning the part along with the purchaser's receipt to our factory, TRANSPORTATION CHARGES PREPAID, at the address listed. THIS WARRANTY IS THE ONLY EXPRESS WARRANTY MADE BY DELTA FAUCET. ANY CLAIMS MADE UNDER THIS WARRANTY MUST BE MADE DURING THE FIVE-YEAR PERIOD REFERRED TO ABOVE. ANY IMPLIED WARRANTIES, INCLUDING THE IMPLIED WARRANTY OF MERCHANTABILITY OF FITNESS FOR A PARTICULAR PURPOSE, ARE LIMITED IN DURATION TO THE DURATION OF THIS WARRANTY. LABOUR CHARGES AND/OR DAMAGE INCURRED IN INSTALLATION, REPAIR OR REPLACEMENT AS WELL AS INCIDENTAL AND CONSEQUENTIAL, SPECIAL, INDIRECT OR PUNITIVE DAMAGES CONNECTED THEREWITH ARE EXCLUDED AND WILL NOT BE PAID BY DELTA FAUCET.

Some states/provinces do not allow limitations on how long an implied warranty lasts, or the exclusion or limitation of incidental or consequential damages, so the above limitations or exclusions may not apply to you. This warranty gives you specific legal rights, and you may also have other rights which vary from state/province to state/province.

This warranty is for commercial products only from Delta Faucet Company and Delta Faucet Canada (a division of Masco Canada Limited) and is void for any damage to this faucet due to misuse, abuse, neglect, accident, improper installation, or any use in violation of instructions furnished by Delta Faucet.

This device complies with Part 15 of the FCC Rules. Operation is subject to the following two conditions:

- (1) this device may not cause harmful interference, and
- (2) this device must accept any interference received, including interference that may cause undesired operation.

Note: This equipment has been tested and found to comply with the limits for a Class A digital device, pursuant to Part 15 of the FCC Rules. These limits are designed to provide reasonable protection against harmful interference when the equipment is operated in a commercial environment. This equipment generates, uses, and can radiate radio frequency energy and, if not installed and used in accordance with the instruction manual, may cause harmful interference to radio communications. Operation of this equipment in a residential area is likely to cause harmful interference in which case the user will be required to correct the interference at his own expense.

Warning: Changes or modifications not expressly approved by Delta could void the user's authority to operate the equipment.

CAN ICES-3 (A) / NMB-3(A)

© 2018 Masco Canada Ltd.

For further technical assistance, call Delta Commercial Technical Service at **1-800-387-8277** (Canada) or **1-877-509-2680** (U.S.A.).

Delta Faucet Canada, a division of Masco Canada Limited  
350 South Edgeware Road, St. Thomas, Ontario, N5P 4L1  
1-800-567-3300 (English) 1-800-265-9245 (French)

Delta Faucet Company  
Box 40980, 55 East 111th St., Indianapolis, IN, U.S.A. 46280  
(317) 848-1812

[www.deltacommercialfaucets.com](http://www.deltacommercialfaucets.com)

**specselect**  
.com