



# MEDIC-AID® HEAVY-DUTY PLASTIC TOILET SEAT

**MODEL #**

**COLOR #**

**MA2155T**

**DESCRIPTION :**

Open front less cover, elongated, heavy-duty, injection molded solid plastic toilet seat. Features four molded-in bumpers, stainless steel side arms with textured plastic grips with finger grooves, check hinges with non-corrosive 300 Series stainless steel posts and pintles and STA-TITE® Commercial Fastening System™. Seat contains DuraGuard® Antimicrobial\* Built-In Seat Protection™. This seat complies with IAPMO/ANSI Z124.5-2013 Plastic Toilet Seats as a class Commercial Heavy Duty. Side arms are ADA tested to 250 pounds.

\* DuraGuard® Antimicrobial does not protect users against bacteria, viruses, or other disease organisms. Always clean and wash this product thoroughly before and after each use.

**SPECIFICATIONS :**

Size:	Elongated
Material:	Plastic
Style:	Open Front less Cover
Bumpers:	Four
Hinges:	Plastic with 300 Series Stainless Steel Posts and Pintles
Fastening System:	STA-TITE® Commercial Fastening System™

**FEATURES :**

- STA-TITE® Commercial Fastening System™
- DuraGuard® Antimicrobial Built-In Seat Protection™
- ADA Tested Stainless Steel Safety Side Arms
- Non-Corrosive 300 Series Stainless Steel Posts and Pintles

**DIMENSIONS :**

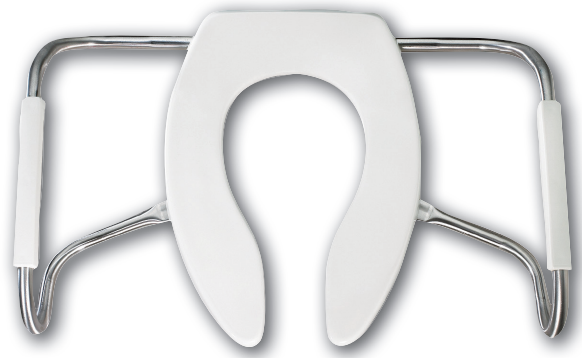
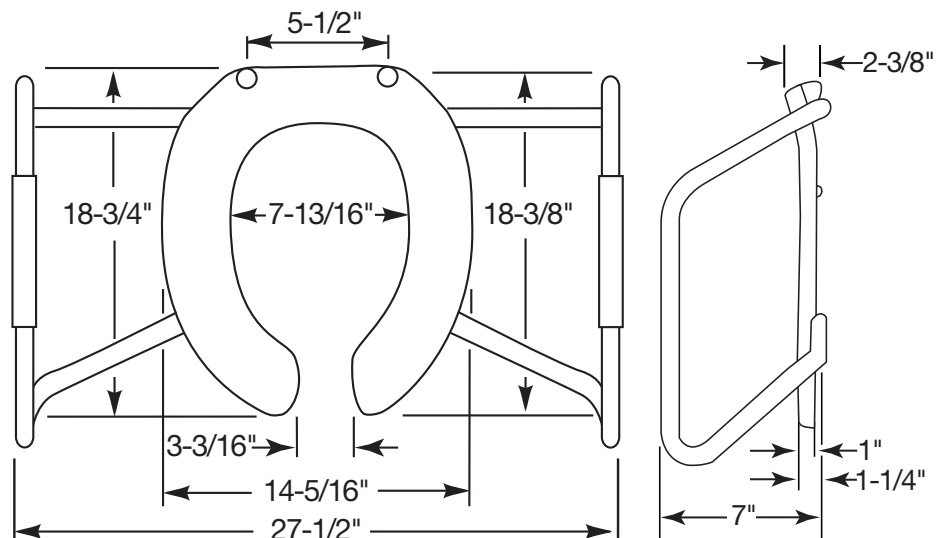

PLASTIC HINGES WITH STAINLESS STEEL POSTS AND PINTLES

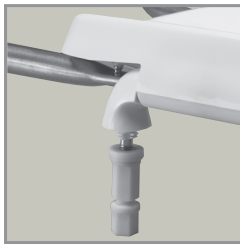

STA-TITE® COMMERCIAL FASTENING SYSTEM™

Proudly Made in the USA

Church Seats, Sheboygan Falls, WI 53085  
www.ToiletSeats.com

Phone: 800-233-7328 Fax: 800-292-3647