



COMMERCIAL HEAVY-DUTY PLASTIC TOILET SEAT

MODEL #

COLOR #

2155CT/2155SSCT _____

DESCRIPTION:

Open front less cover, elongated, heavy-duty, injection molded solid plastic toilet seat. Features four molded-in bumpers, non self-sustaining (2155CT) or self-sustaining (2155SSCT) check hinges with non-corrosive 300 Series stainless steel posts and pintles and STA-TITE® Commercial Fastening System™. Seat contains DuraGuard® Antimicrobial* Built-In Seat Protection™. This seat complies with IAPMO/ANSI Z124.5-2013 Plastic Toilet Seats as a class Commercial Heavy Duty.

* DuraGuard® Antimicrobial does not protect users against bacteria, viruses, or other disease organisms. Always clean and wash this product thoroughly before and after each use.

SPECIFICATIONS:

Size:	Elongated
Material:	Plastic
Style:	Open Front less Cover
Bumpers:	Four
Hinges:	Plastic Non Self-Sustaining (2155CT) or Self-Sustaining (2155SSCT) with 300 Series Stainless Steel Posts and Pintles
Fastening System:	STA-TITE® Commercial Fastening System™

FEATURES:

STA-TITE® Commercial Fastening System™

DuraGuard® Antimicrobial Built-In Seat Protection™

Non-Corrosive 300 Series Stainless Steel Posts and Pintles

DIMENSIONS:

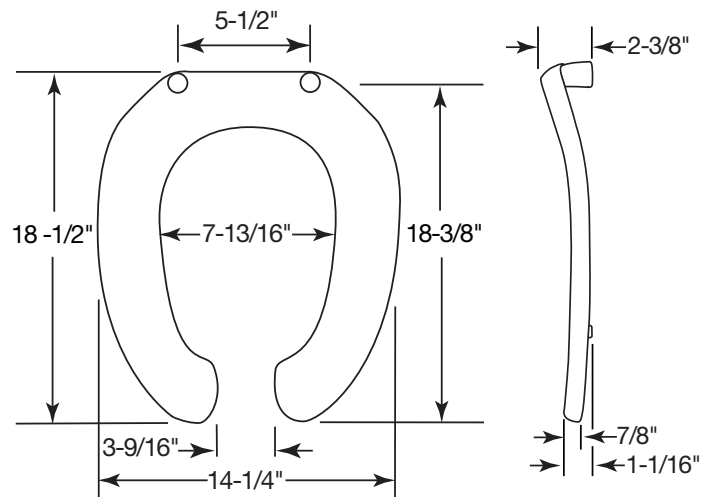

PLASTIC HINGES WITH
STAINLESS STEEL POSTS
AND PINTLES

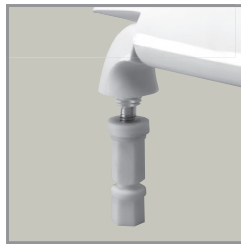

STA-TITE® COMMERCIAL
FASTENING SYSTEM™

Proudly Made in the USA

Church Seats, Sheboygan Falls, WI 53085
www.ToiletSeats.com

Phone: 800-233-7328 Fax: 800-292-3647